

---

## Agile+ Double Sided Desk

Assembly Instructions

# Agile+ Double Sided Desk

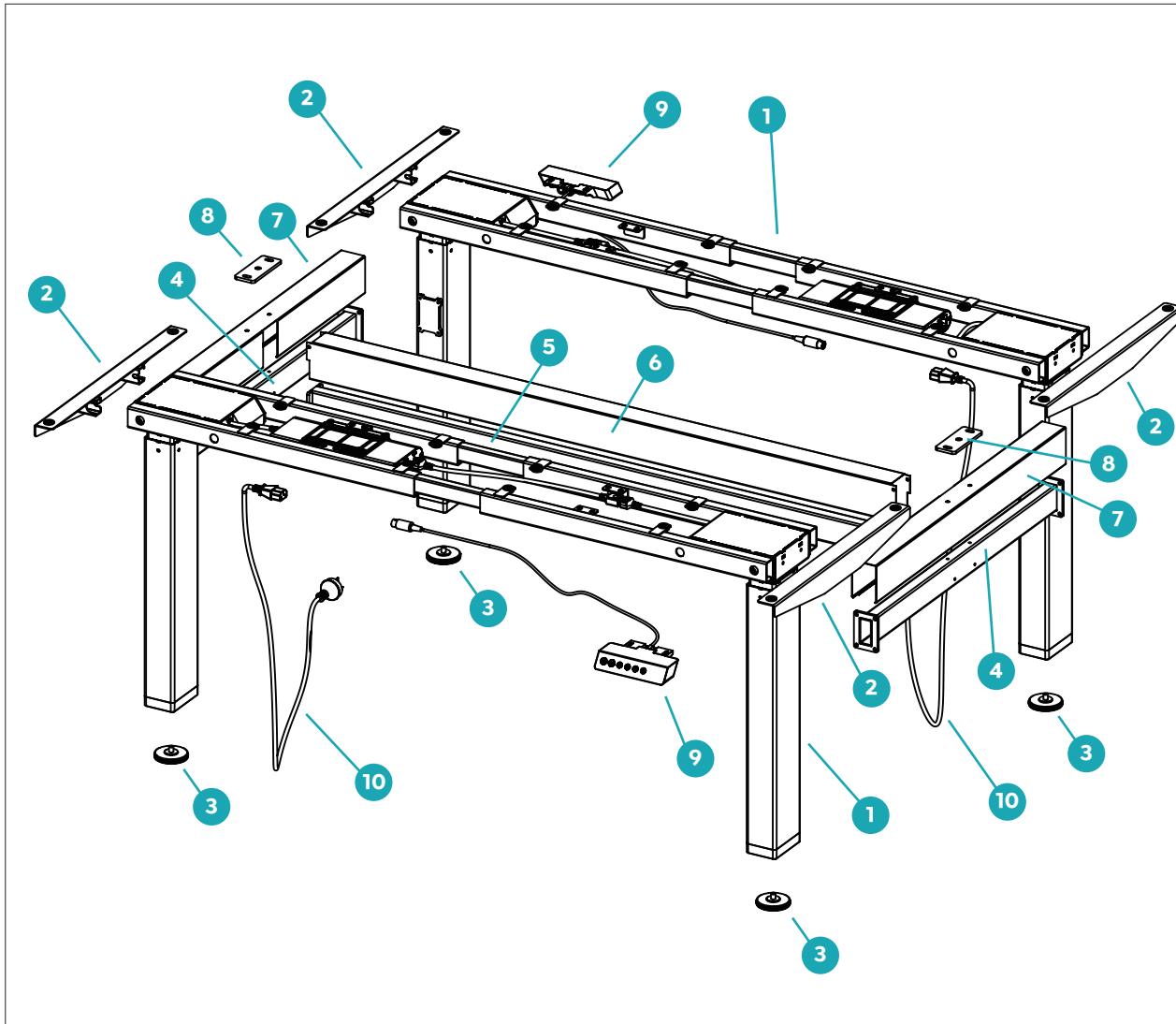

## Components List





**Check List**

NO.	1	2	3	4	5	6	7	8	9	10
QTY.	2	4	4	2	1	1	2	2	2	2

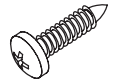

A (8pcs)	B (24pcs)	C (32pcs)	D (4pcs)
			
M6x12mm	M5x10mm	ST5.0x23mm	ST4.2x16mm

E (2pcs)	F	G
		
M8x20mm	M5	M3

## STEP 1:

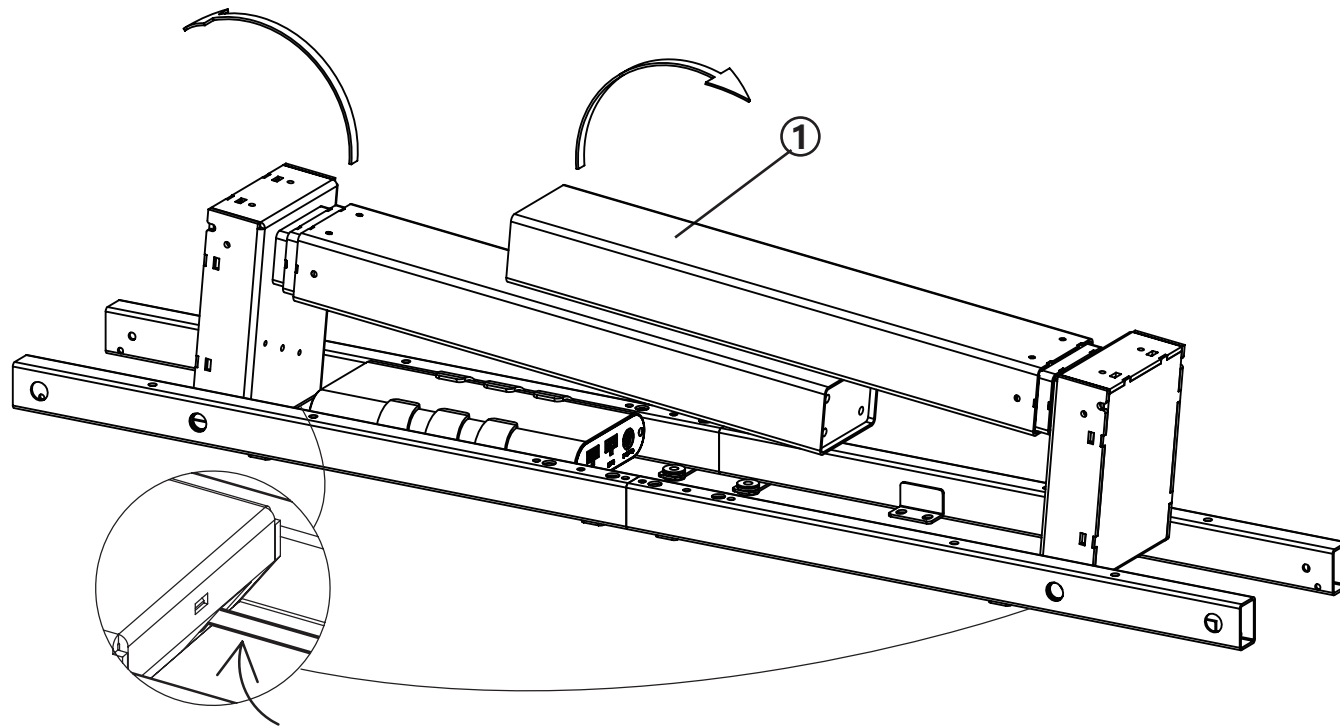

Be careful with the cable.



# Agile+ Double Sided Desk

Assembly Instructions

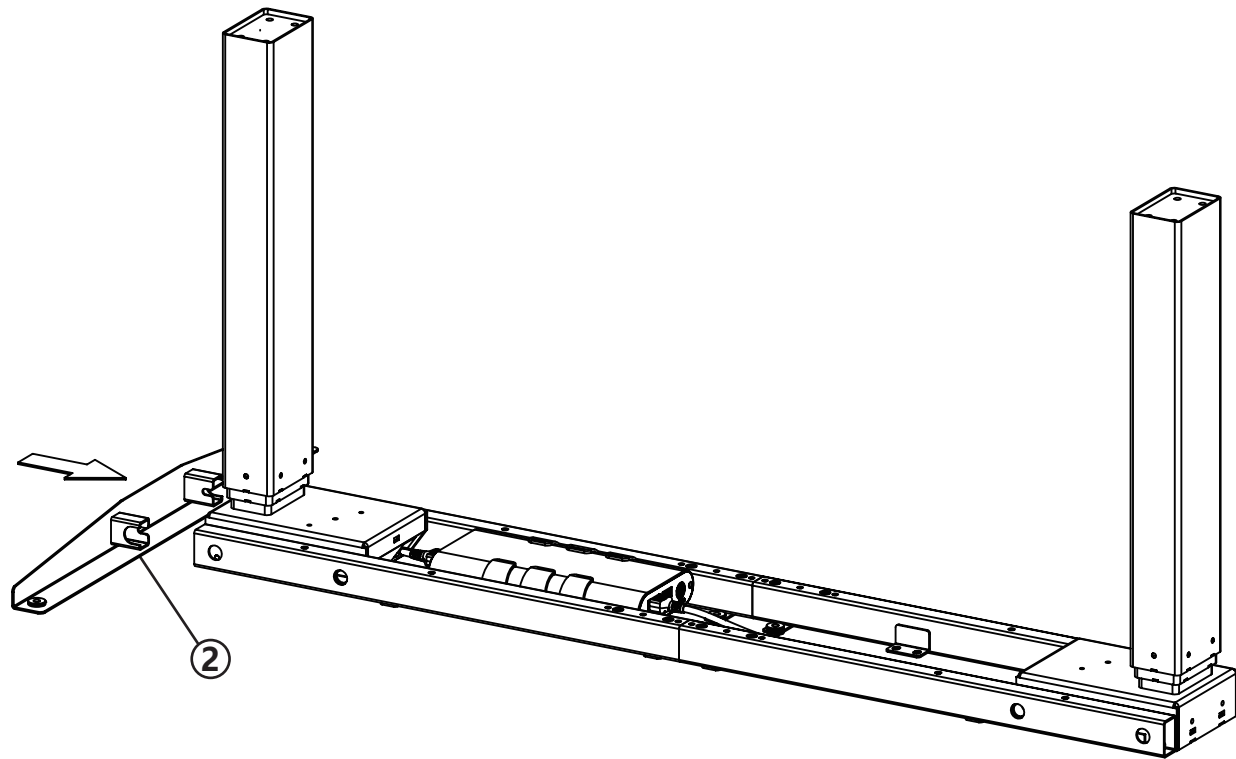
## STEP 2:



## STEP 3:

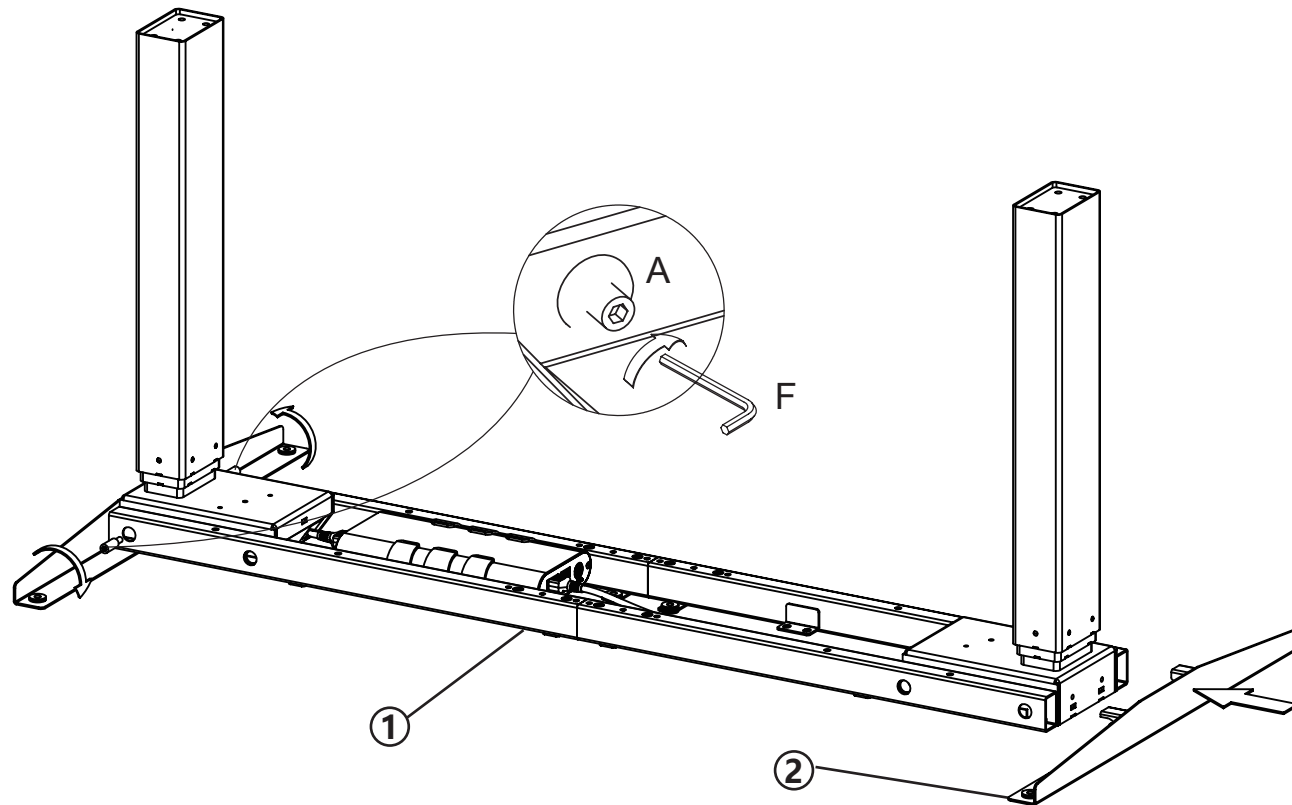

A (2pcs)	F
	
M6x12mm	M5



# Agile+ Double Sided Desk

## Assembly Instructions

### STEP 4:

A (2pcs)	F
	
M6x12mm	M5

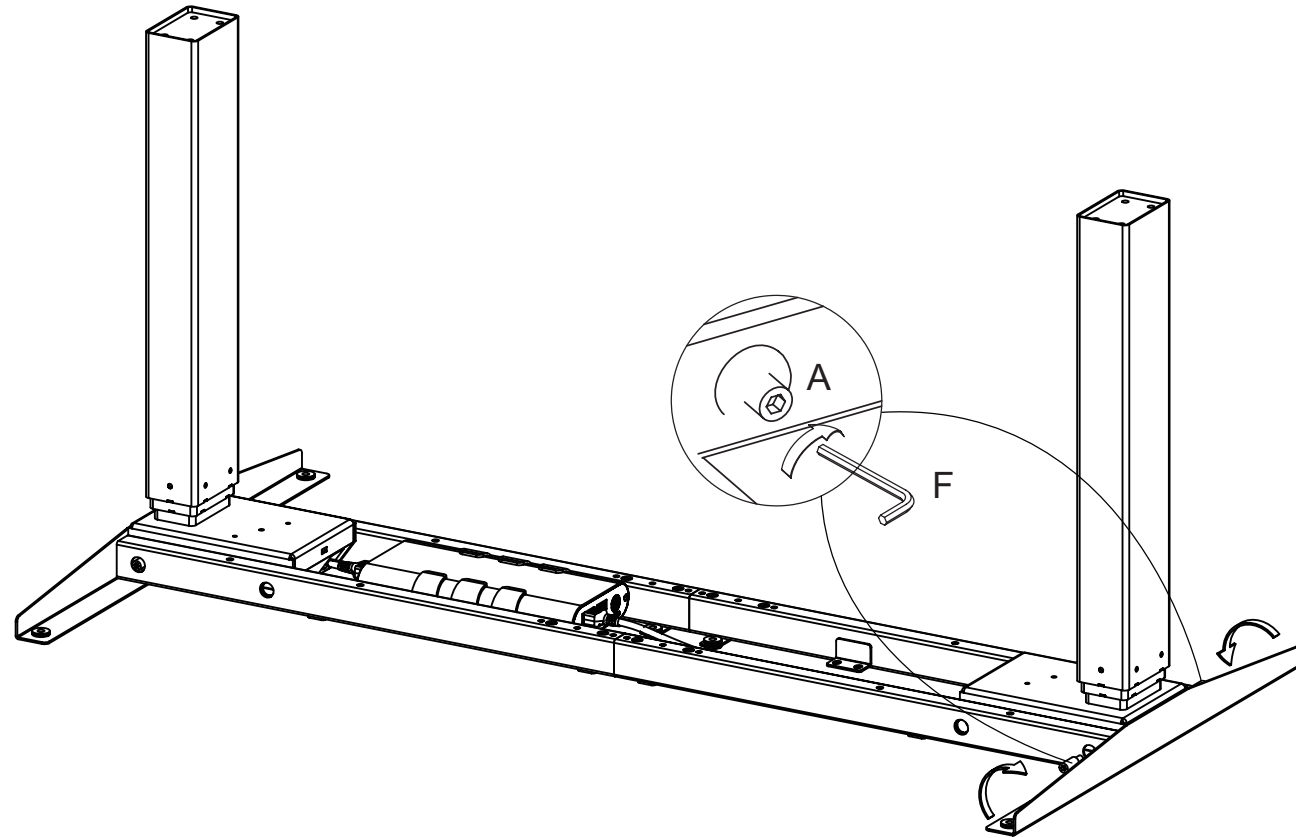

## STEP 5:

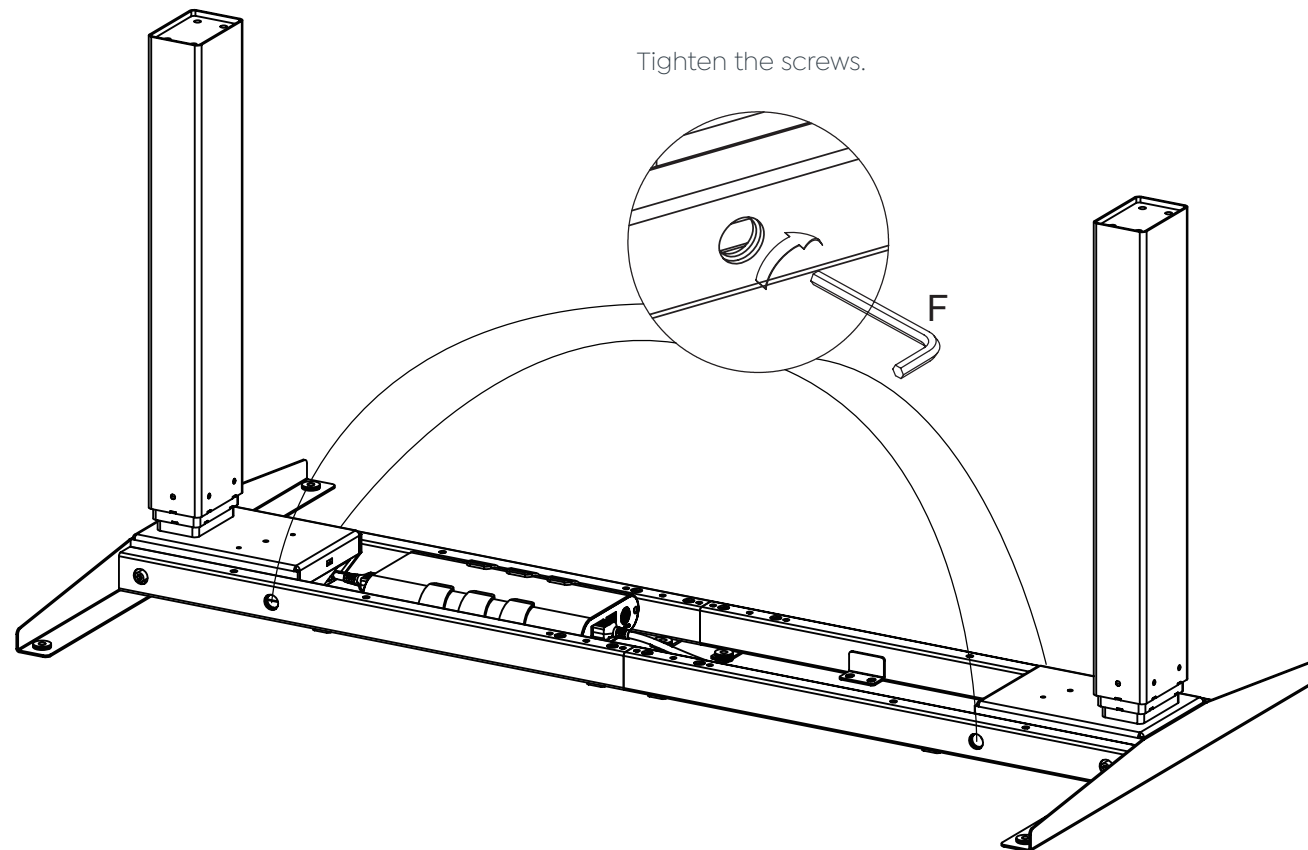
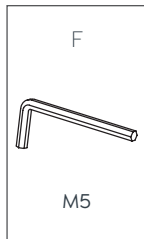

# Agile+ Double Sided Desk

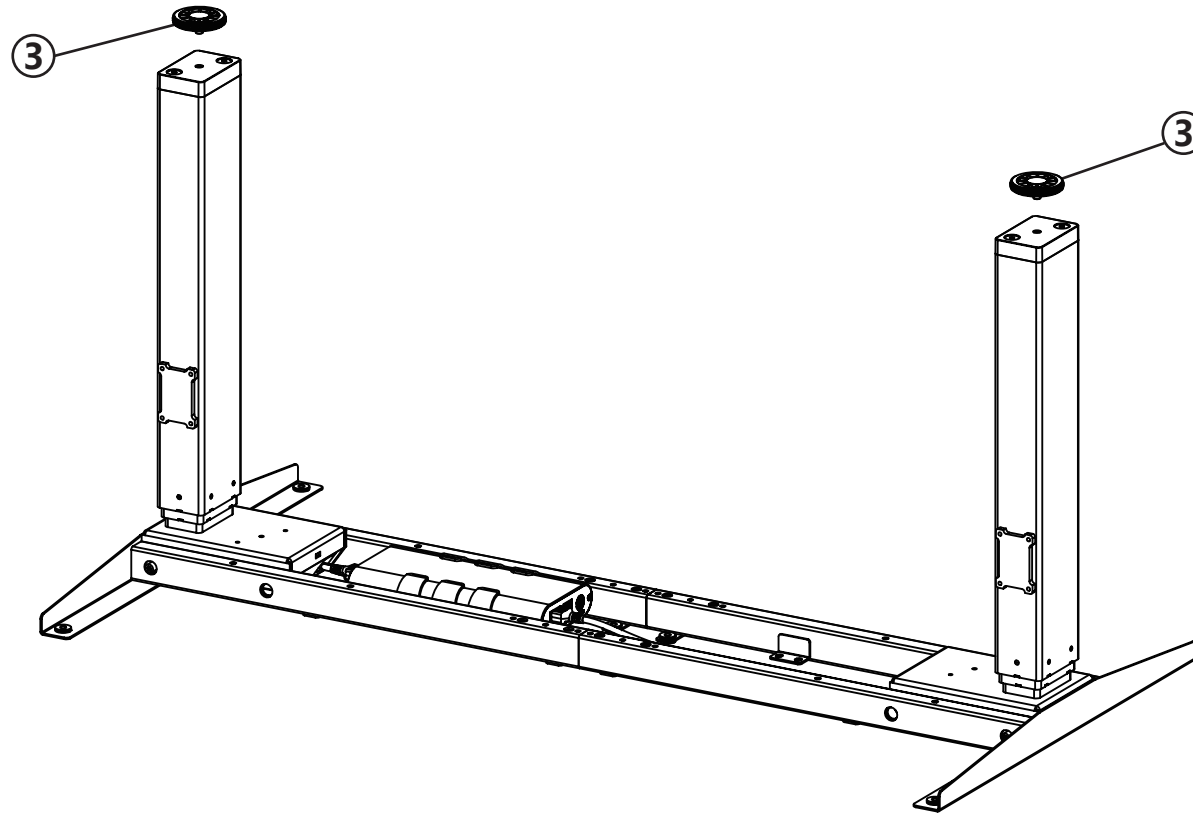

## Assembly Instructions

### STEP 6:





## STEP 7:

B (16pcs)	G
	
M5x10mm	M3

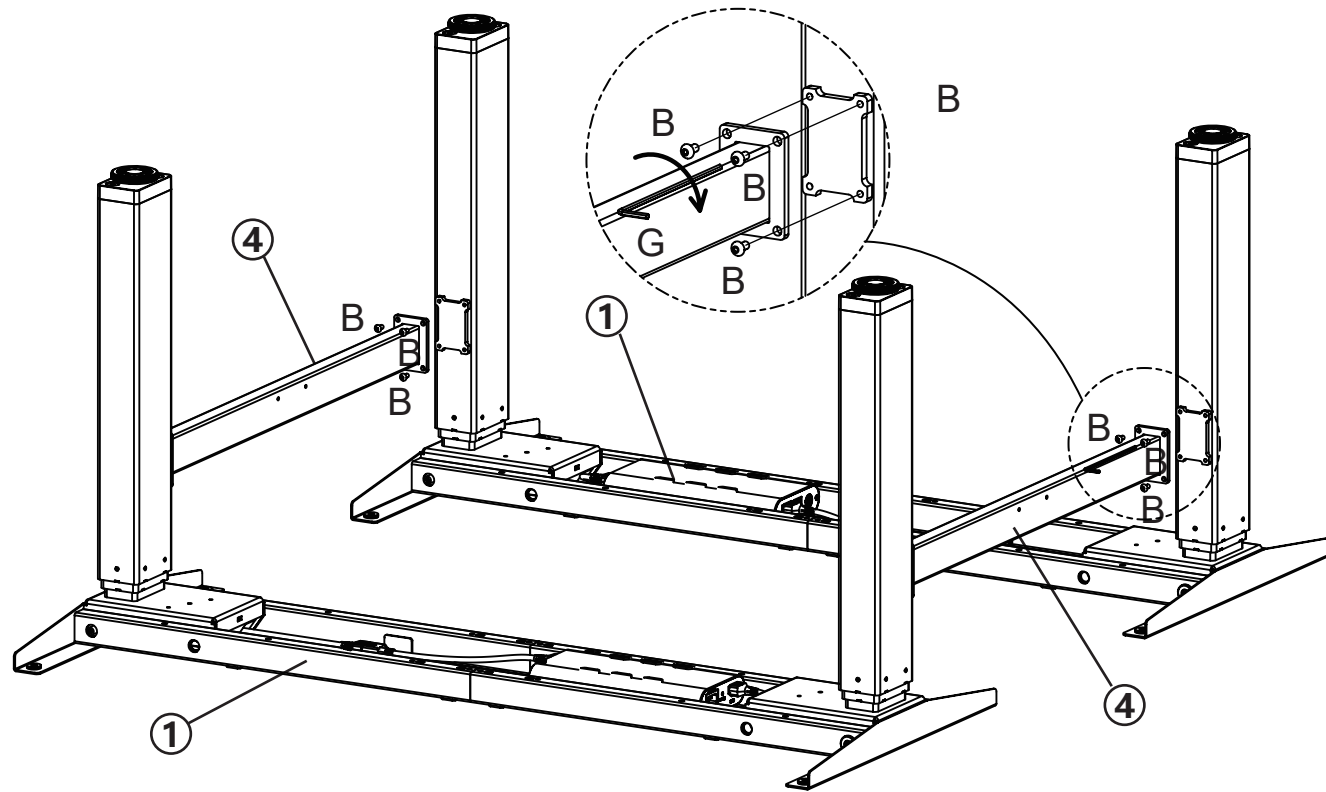



# Agile+ Double Sided Desk

## Assembly Instructions

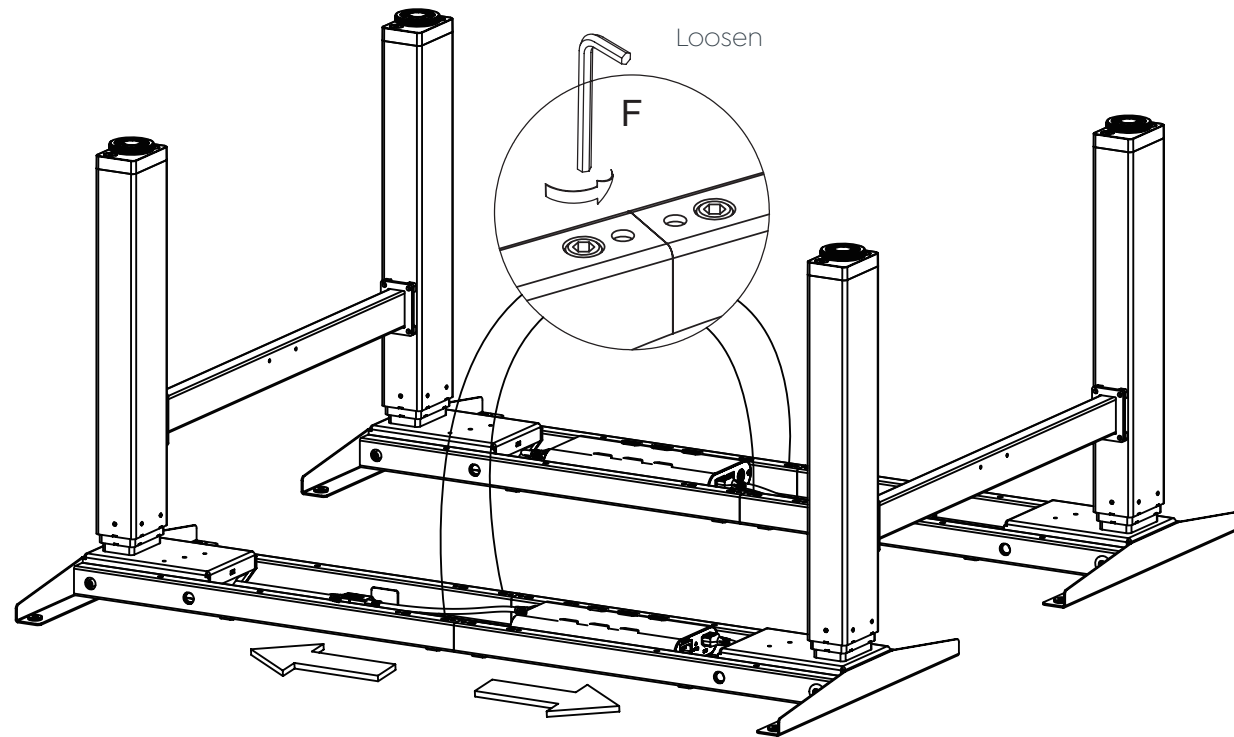
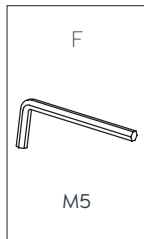
### STEP 8:



## STEP 9:

B (4pcs)	G
	
M5x10mm	M3

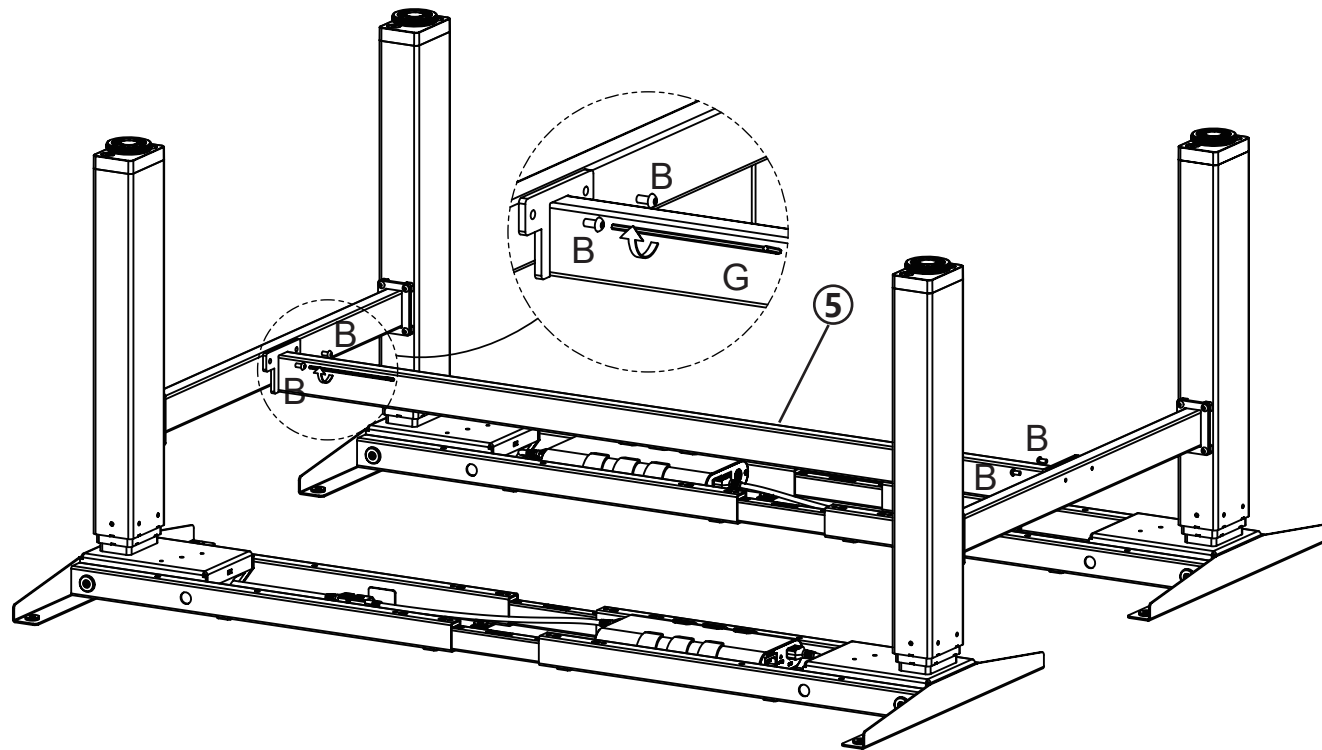

# Agile+ Double Sided Desk

## Assembly Instructions

### STEP 10:

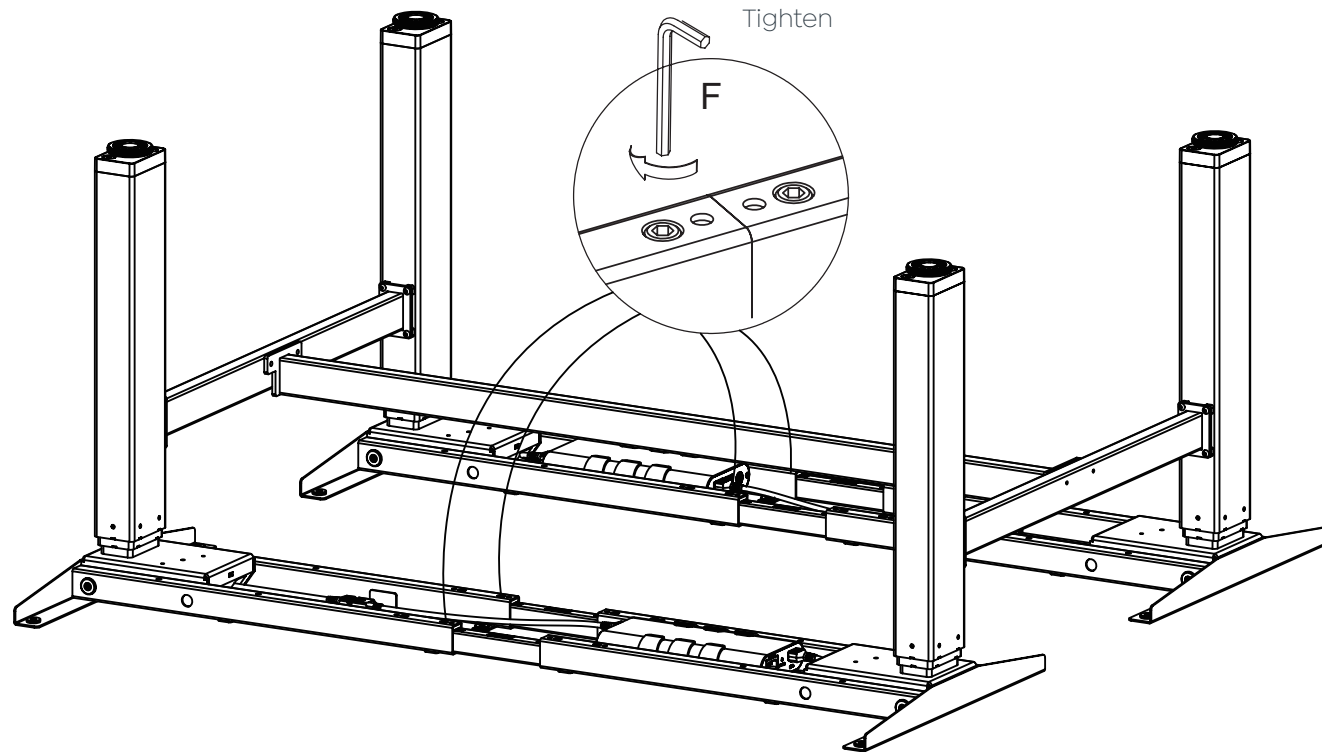
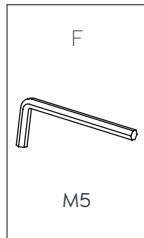

**STEP 11:**

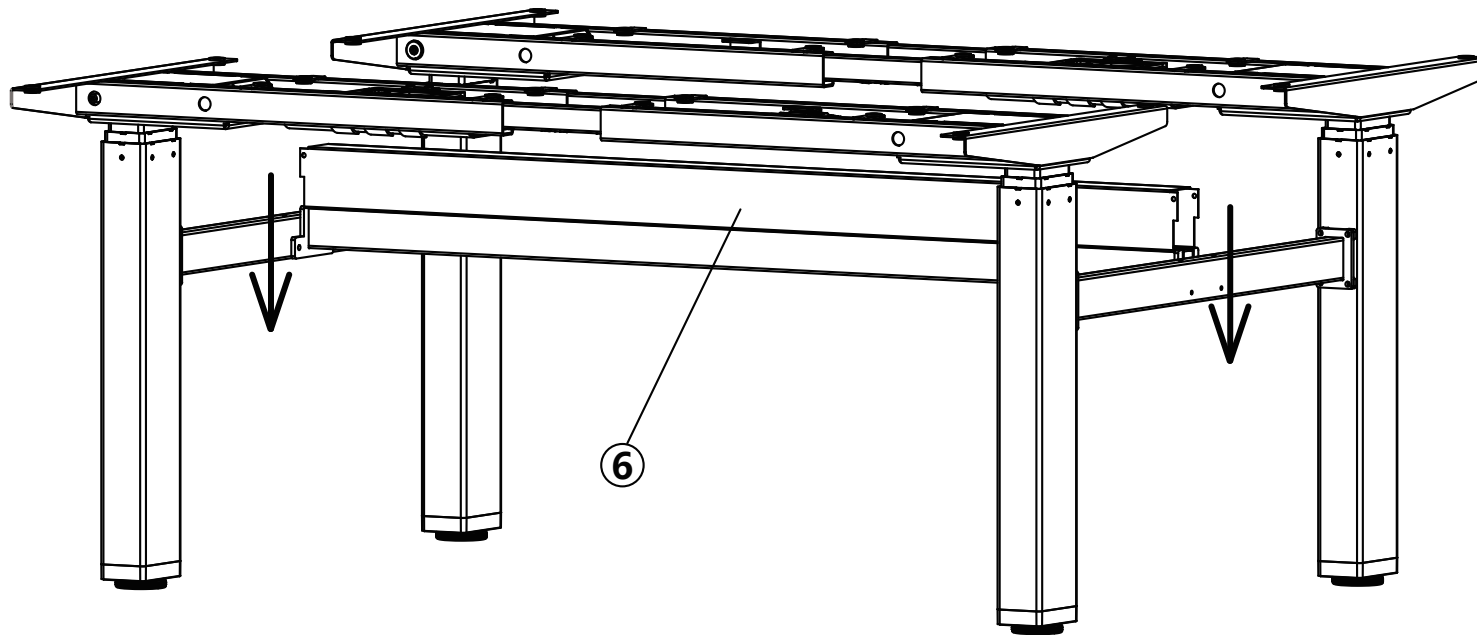

# Agile+ Double Sided Desk

Assembly Instructions

## STEP 12:

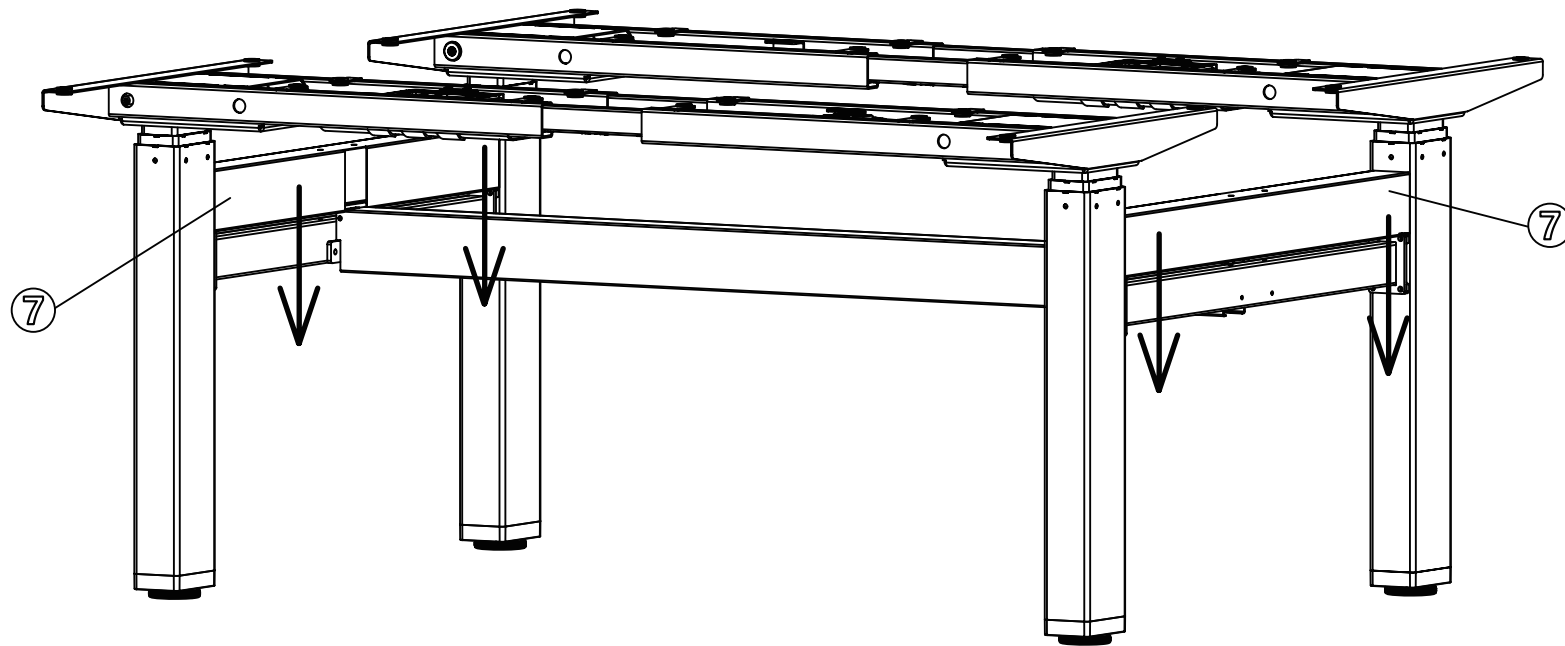

## STEP 13:

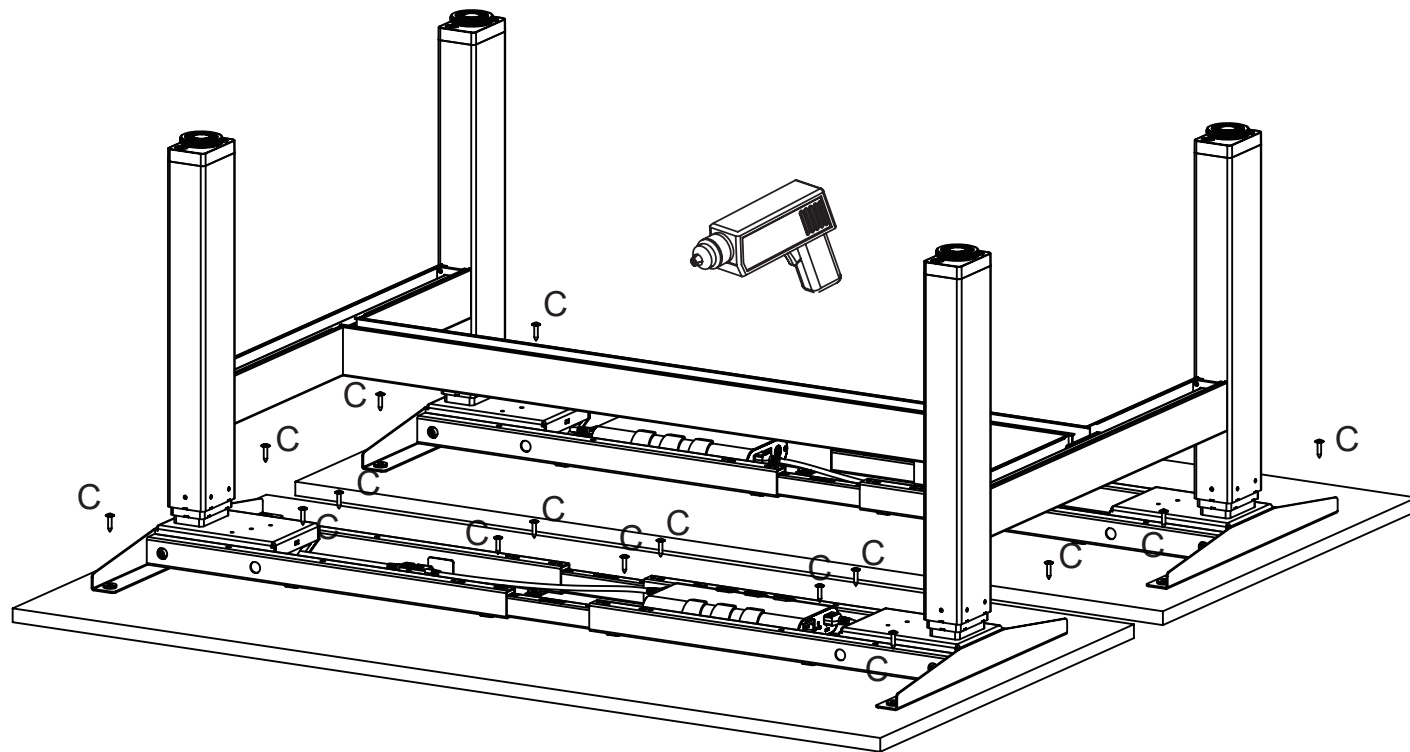
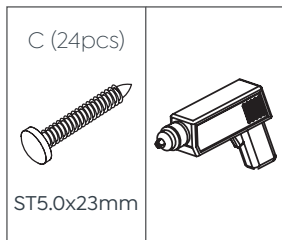

# Agile+ Double Sided Desk

## Assembly Instructions

### STEP 14:

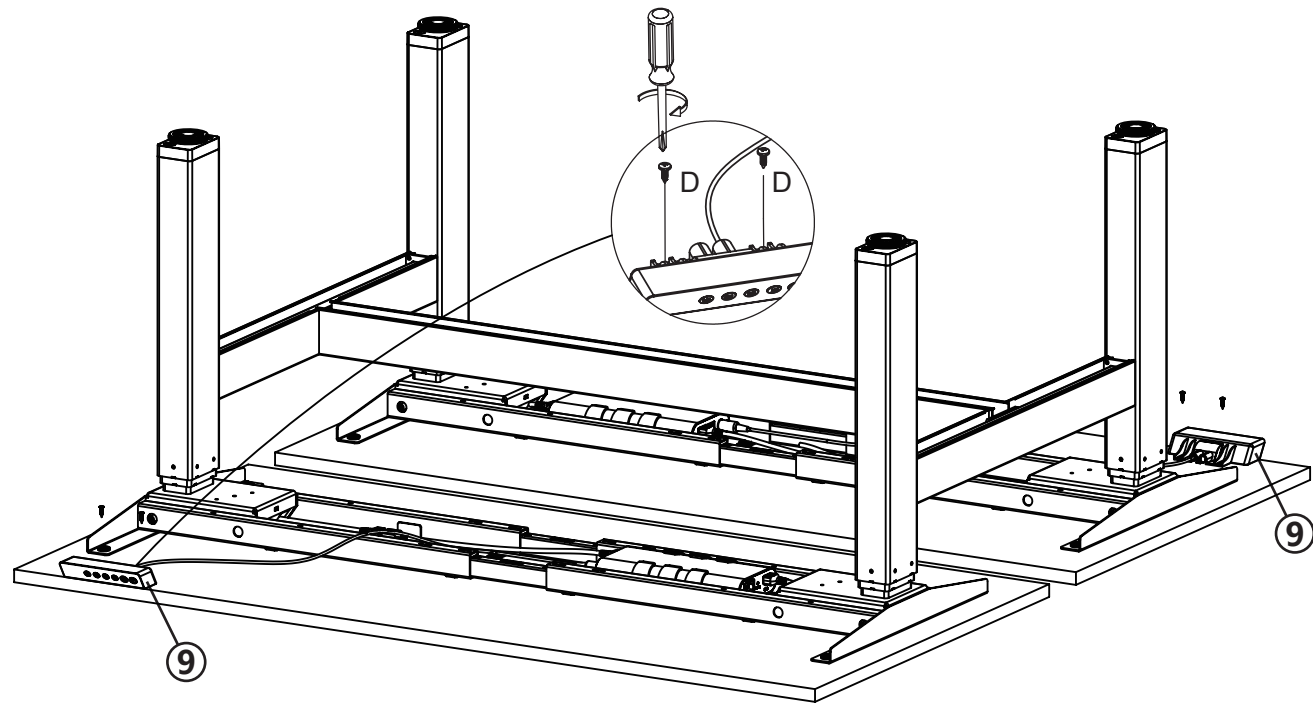
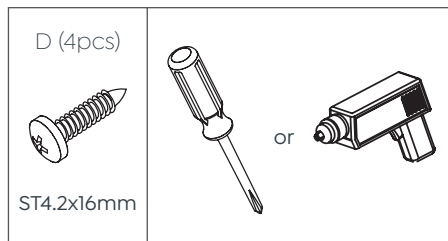



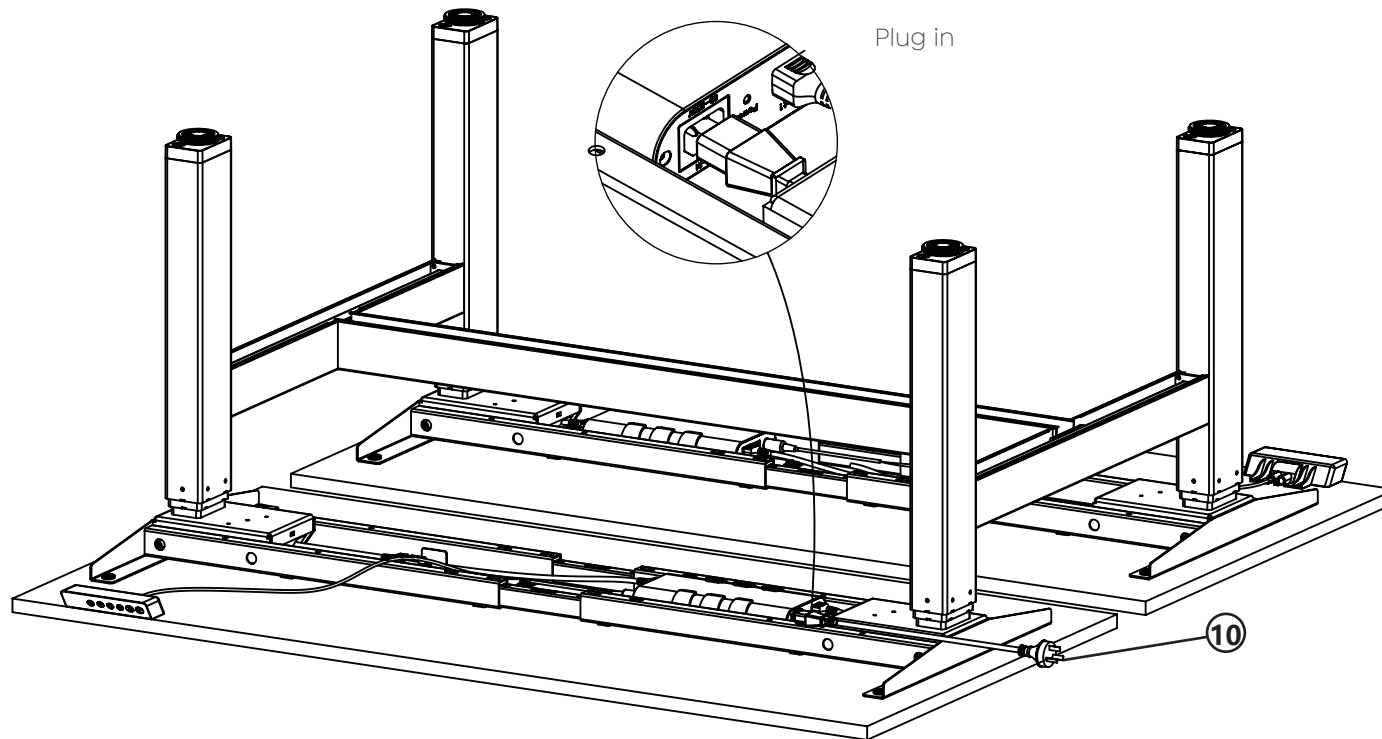

## STEP 15:



# Agile+ Double Sided Desk

## Assembly Instructions

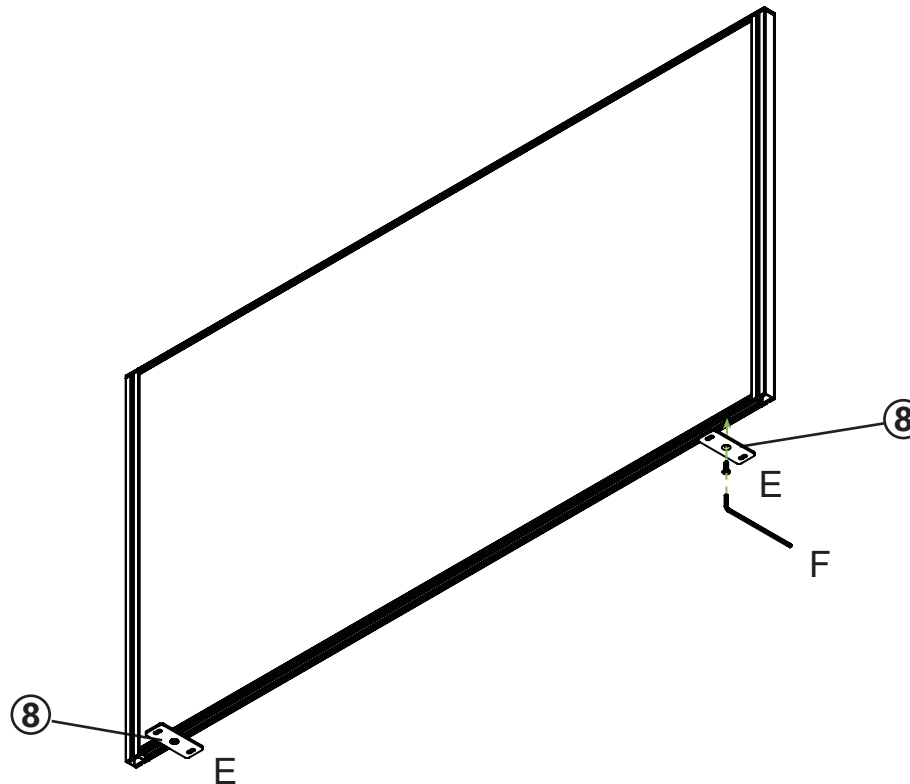

### STEP 16:

E (2pcs)	F
	
M8x20mm	M5



Studio50  
Screens are  
Australian  
Made.

## STEP 17:

B (4pcs)	F
	
M5x10mm	M5

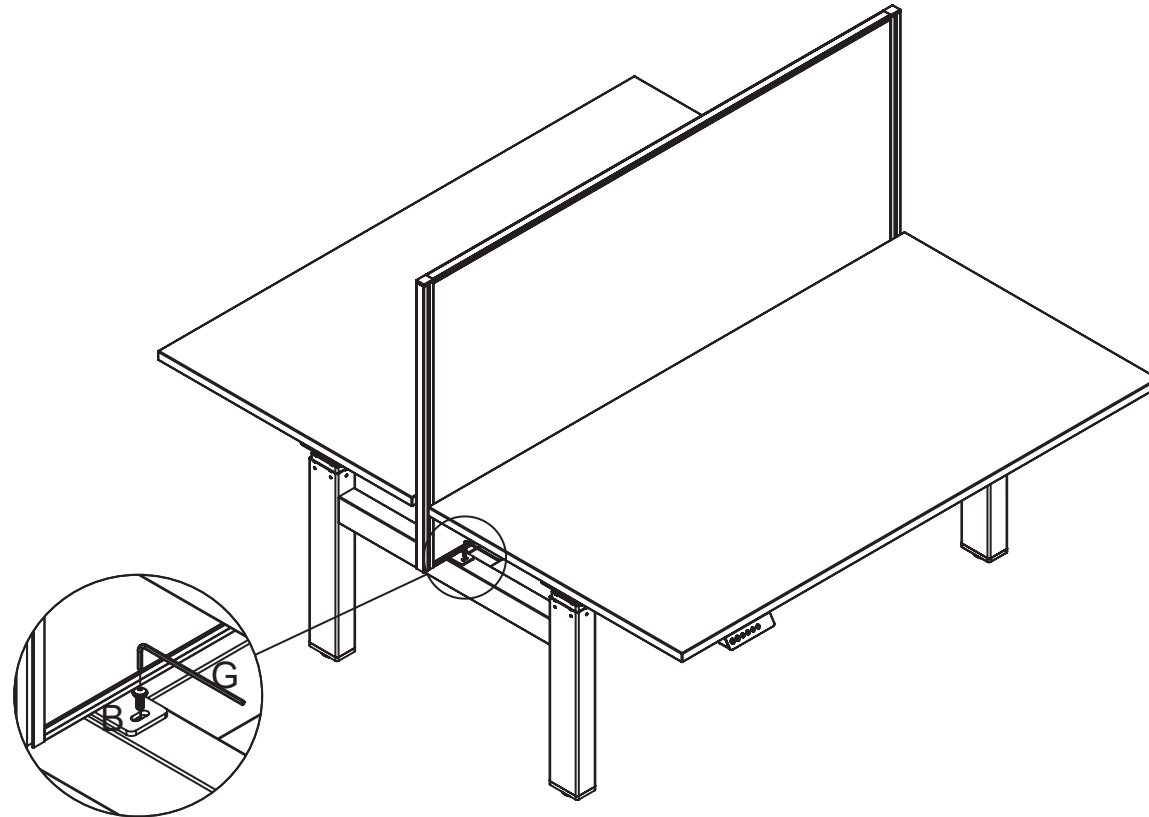

# Agile+ Double Sided Desk

## Assembly Instructions

### STEP 18:

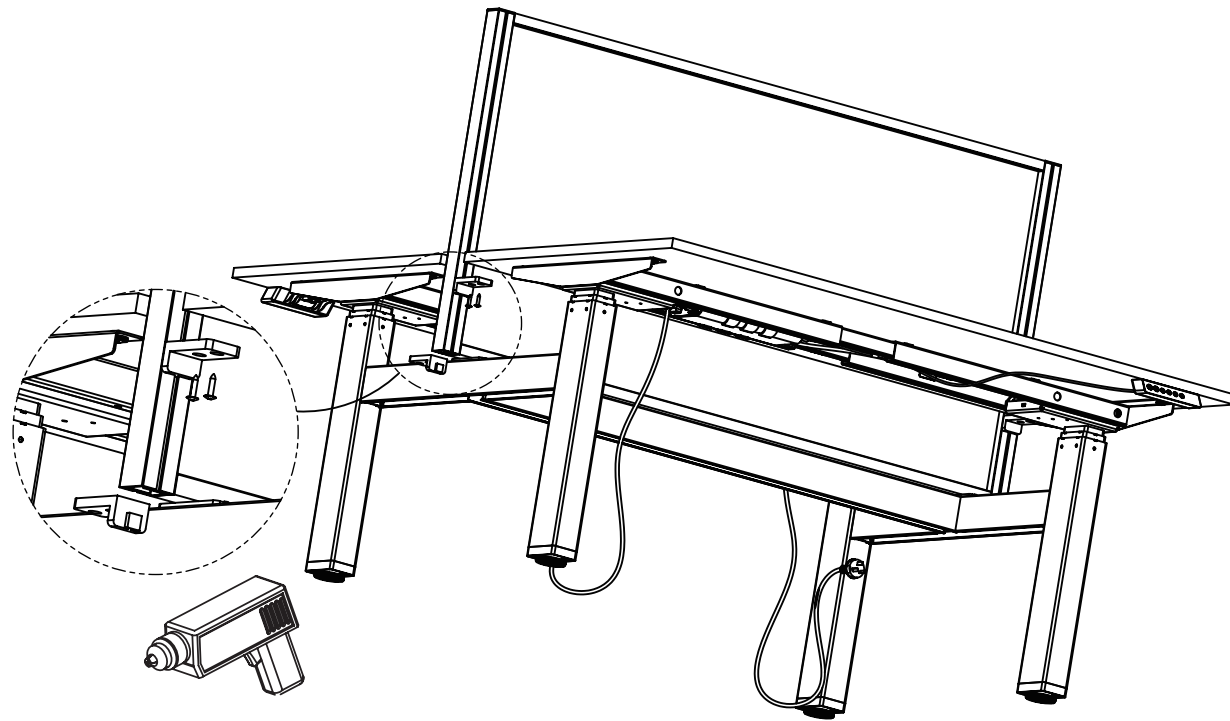
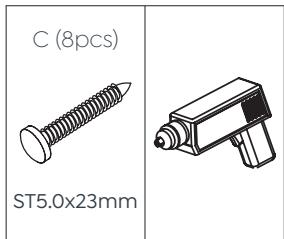

**STEP 19:**

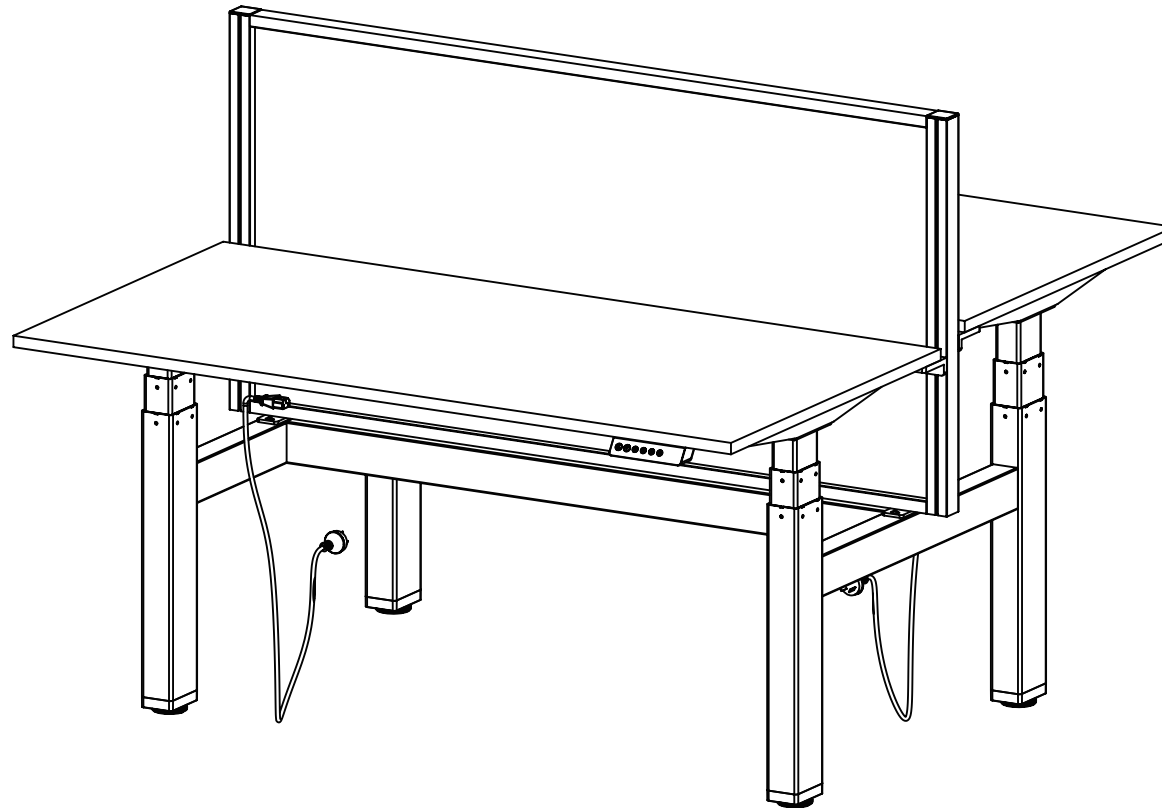

# Agile+ Double Sided Desk

## Assembly Instructions

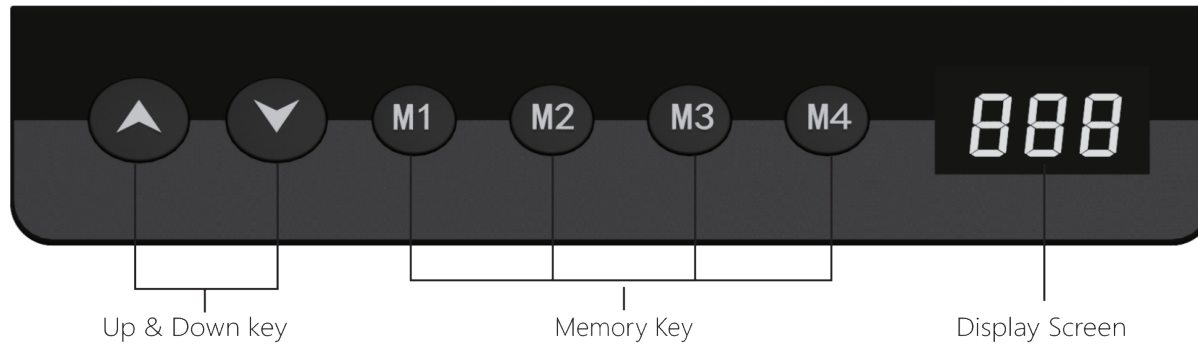

The whole handset surface is a button panel. If there is no press within 30 seconds, the screen is locked and M1/M2/M3/M4 keys are locked correspondingly, you should press Up or Down key first, it can be used when the display screen light up.

### ■ Up or Down Key

To adjust the height of the desk, keep pressing on "up" or "down" until it fits your best position.

### ■ Display Screen

Display the height value of the desk.

### ■ Memory Key ( M1/ M2/ M3/ M4 )

After setting memory keys, the desk can lift automatically to memory height.

※ How to set memory mode

Please keep pressing M1/M2/M3/M4 key for 5 seconds, until "be" sound, the memory height is successfully saved. Then press M1/M2/M3/M4, the desk moves to memory height automatically.

### ■ Safety Function

When the desktop is on the rise or down, encountered reverse resistance, the desk will rebound.

### ■ Handset shows error code and solution

Error code	Fault cause	Solution
ER1	Motor stop	Power off and restart. If fault still exists, it is motor problem.
ER2	Synchro error beyond 15mm	Power off and restart. If handset display RST(DOWN key unlocked), keep touching DOWN key to the lowest normal number.
ER3	Cable fault	Check motor cable off or broken, power off and restart.
ER4	Communication fault	Check cables for handset and controller, power off and restart.
ER5	Overload protection	2 legs Load>180kg or 3 legs load>160kg, display ER5. Lighten loads, power off and restart.
Hot	Run continuously for 2.5 to 5 minutes.	Overload, power protection, automatic recovery after five minutes

### ■ Setting solution for desk function

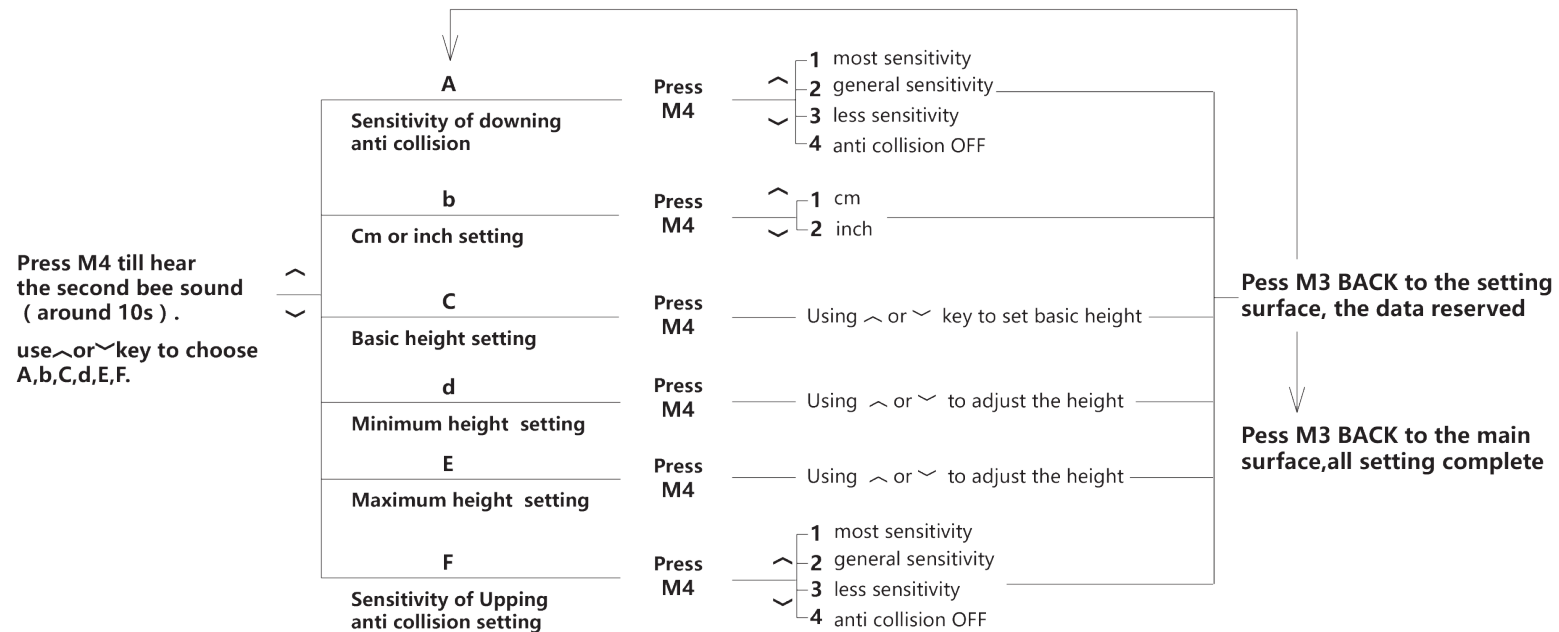



**Sydney** 02 8188 2732  
**Melbourne** 03 9111 0315  
**Brisbane** 07 3733 1923  
**Adelaide** 08 7111 0810  
**Perth** 08 9468 2707

[info@olgoffice.com](mailto:info@olgoffice.com)

[myolg.online](https://myolg.online) | [olgoffice.com](https://olgoffice.com) | [officedesigner.net](https://officedesigner.net) | [motionoffice.com](https://motionoffice.com)