

Agile

Installation Guide - Electric 2 Column

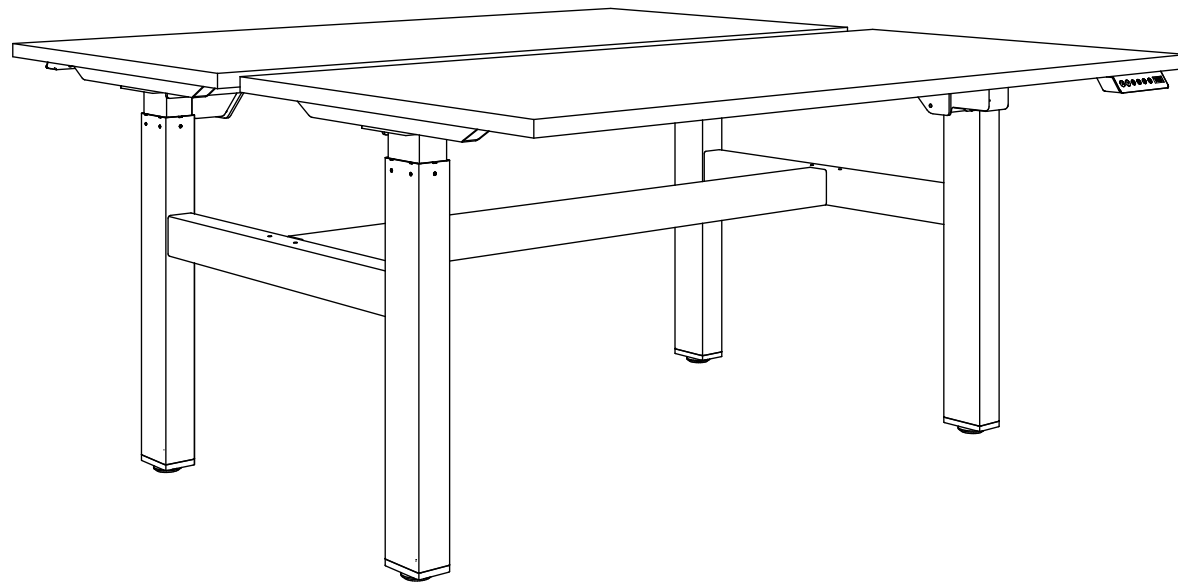

freeway



Parts:

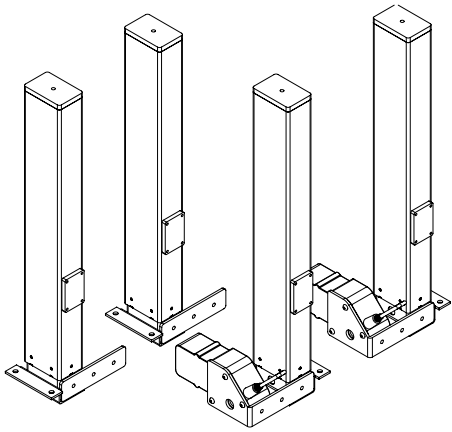

2 x L&R Leg Pair

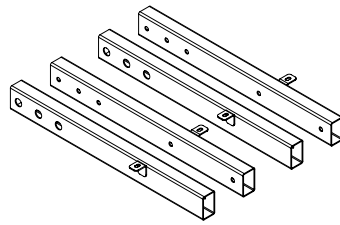

2 x L&R Leg Rail Pair

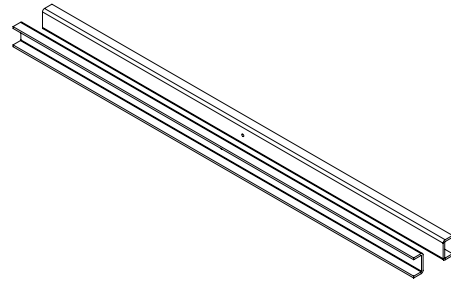

2 x Cross Rail

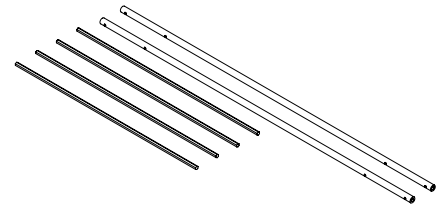

2 x Drive Shaft

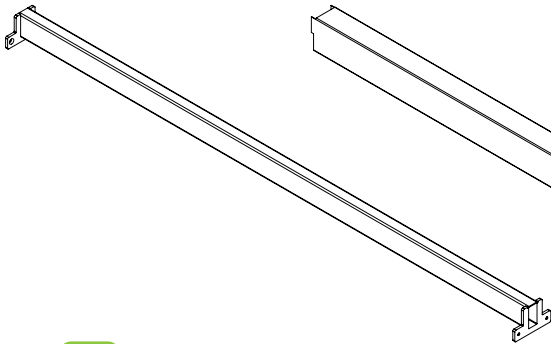

1 x Cross Beam

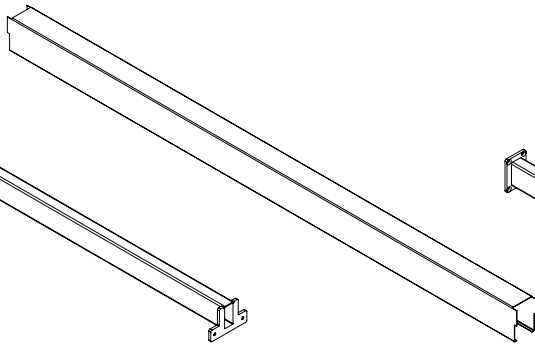

1 x Cross Beam Cover

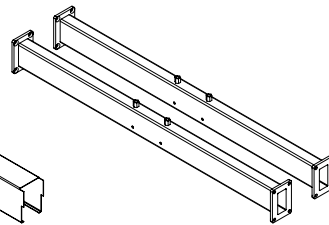

2 x Leg Beam

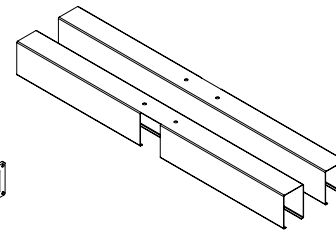

2 x Leg Beam Cover

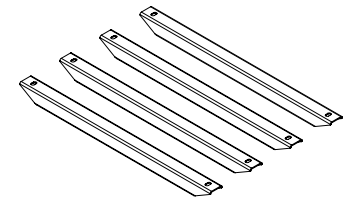

4 x L&R Support Bar

Parts:

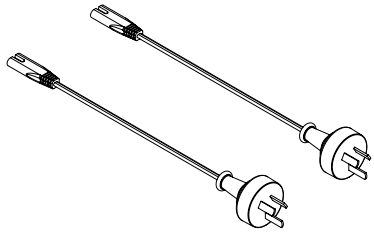

2 x Power Cord

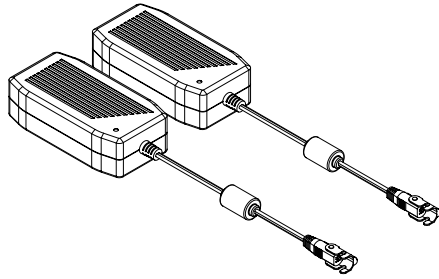

2 x Power Supply

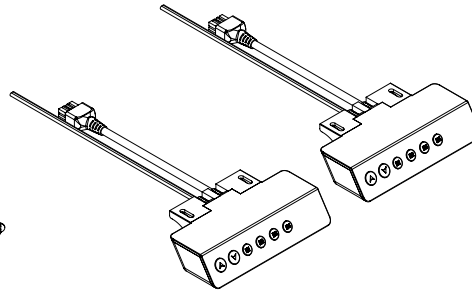

2 x Handset

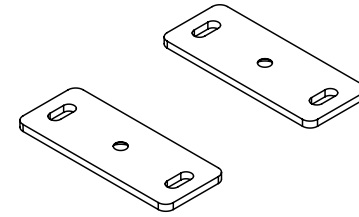

2 x Screen Bracket

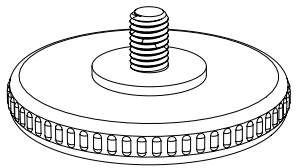

4 x Levelling Foot



16 x M8x10

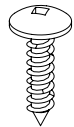

20 x ST5.0x23



4 x ST3.9x13

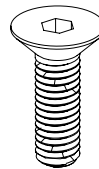

2 x M8x20



4 x M5x15



20 x M5x10

Step 1



8 x M8x10

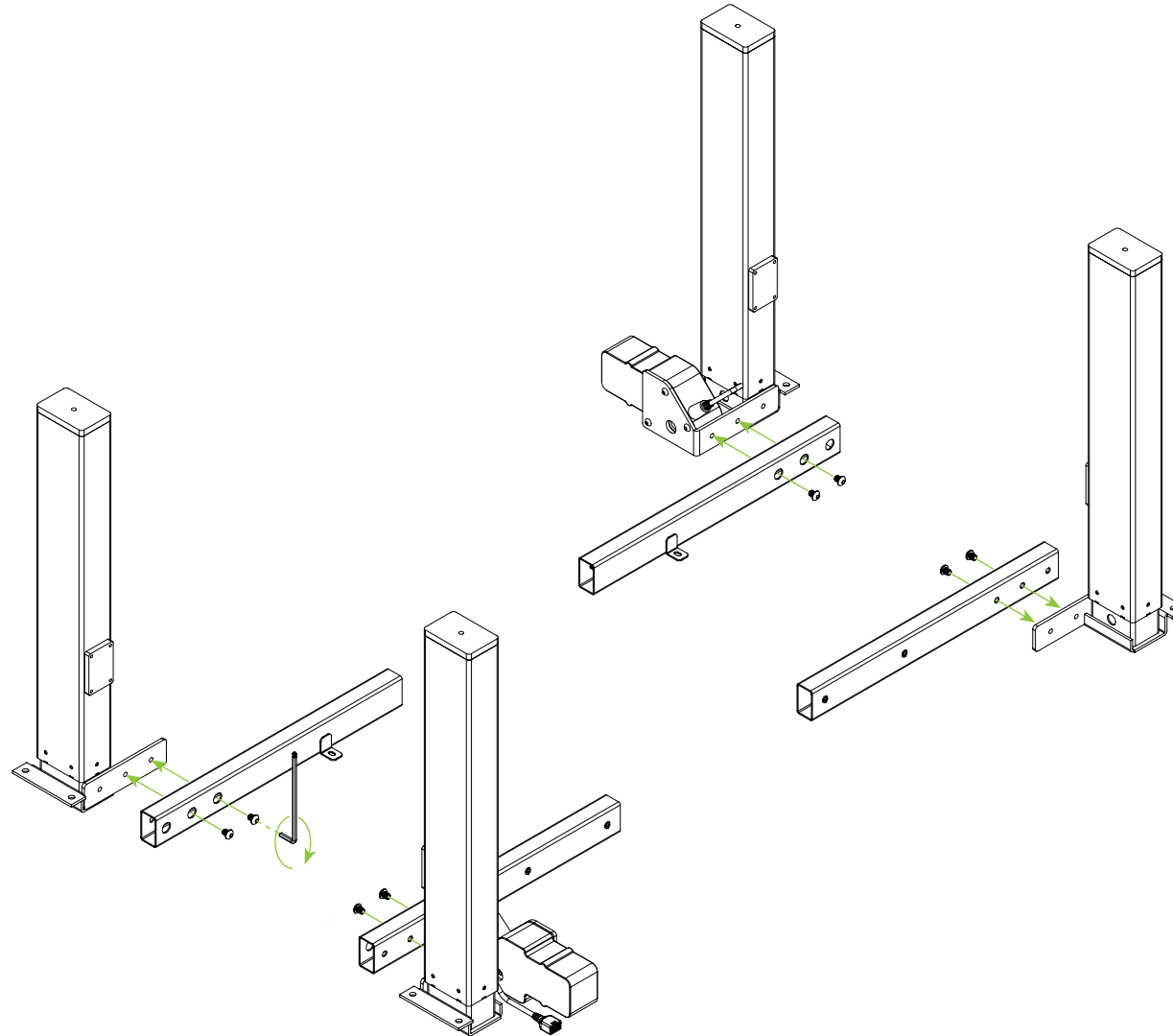

Step 2



8 x M8x10

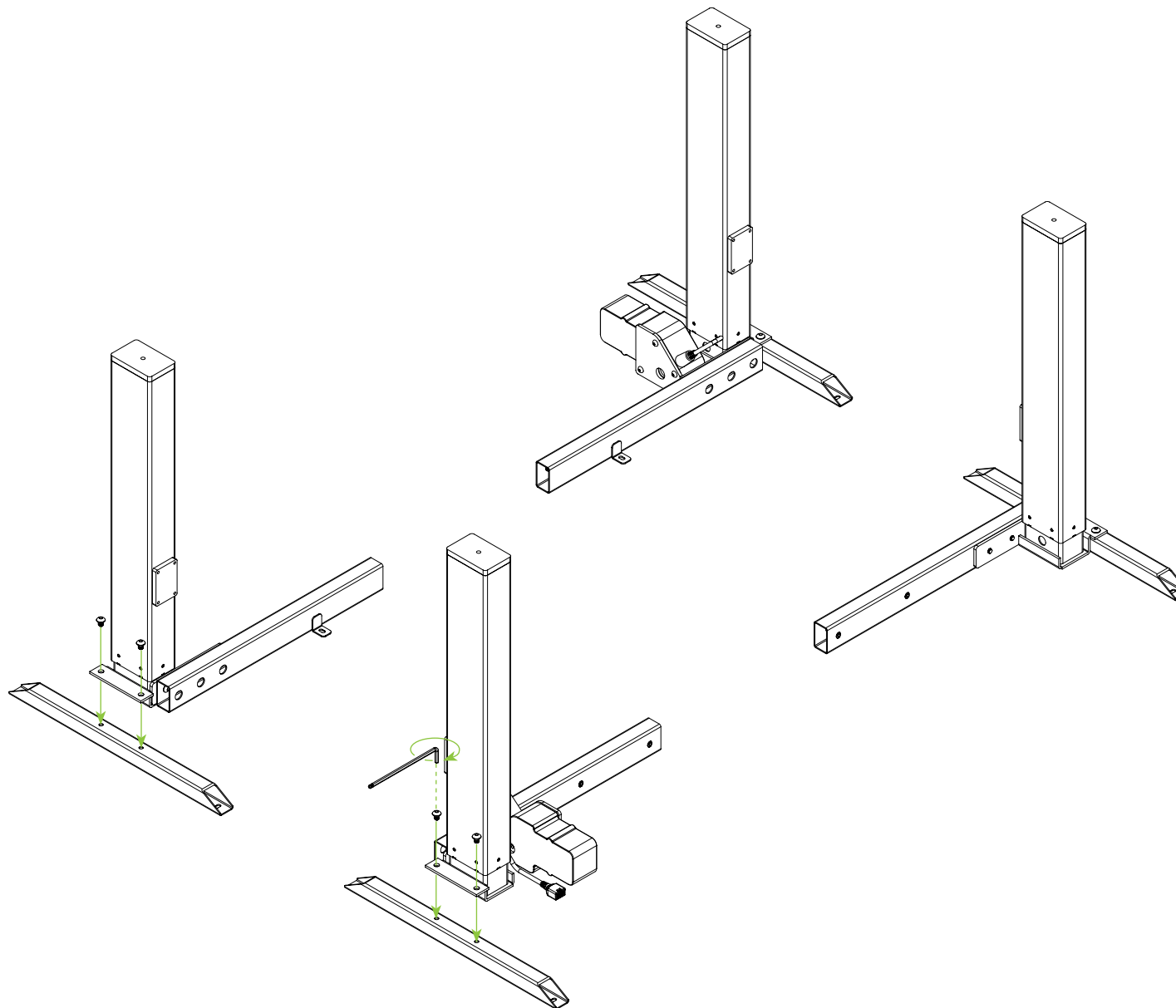

Step 3

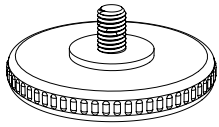

4 x Levelling Foot

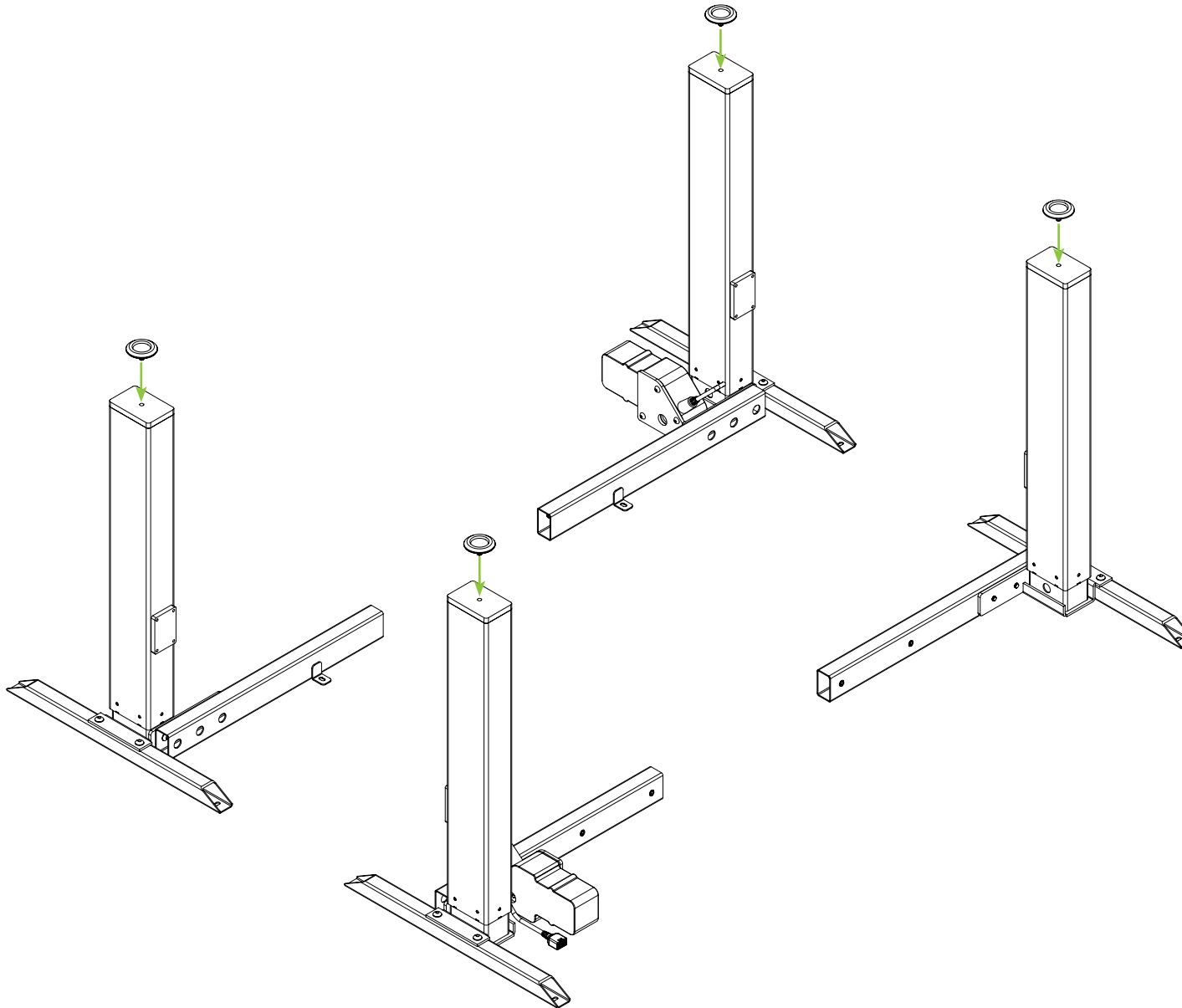

Step 4



16 x M5x10

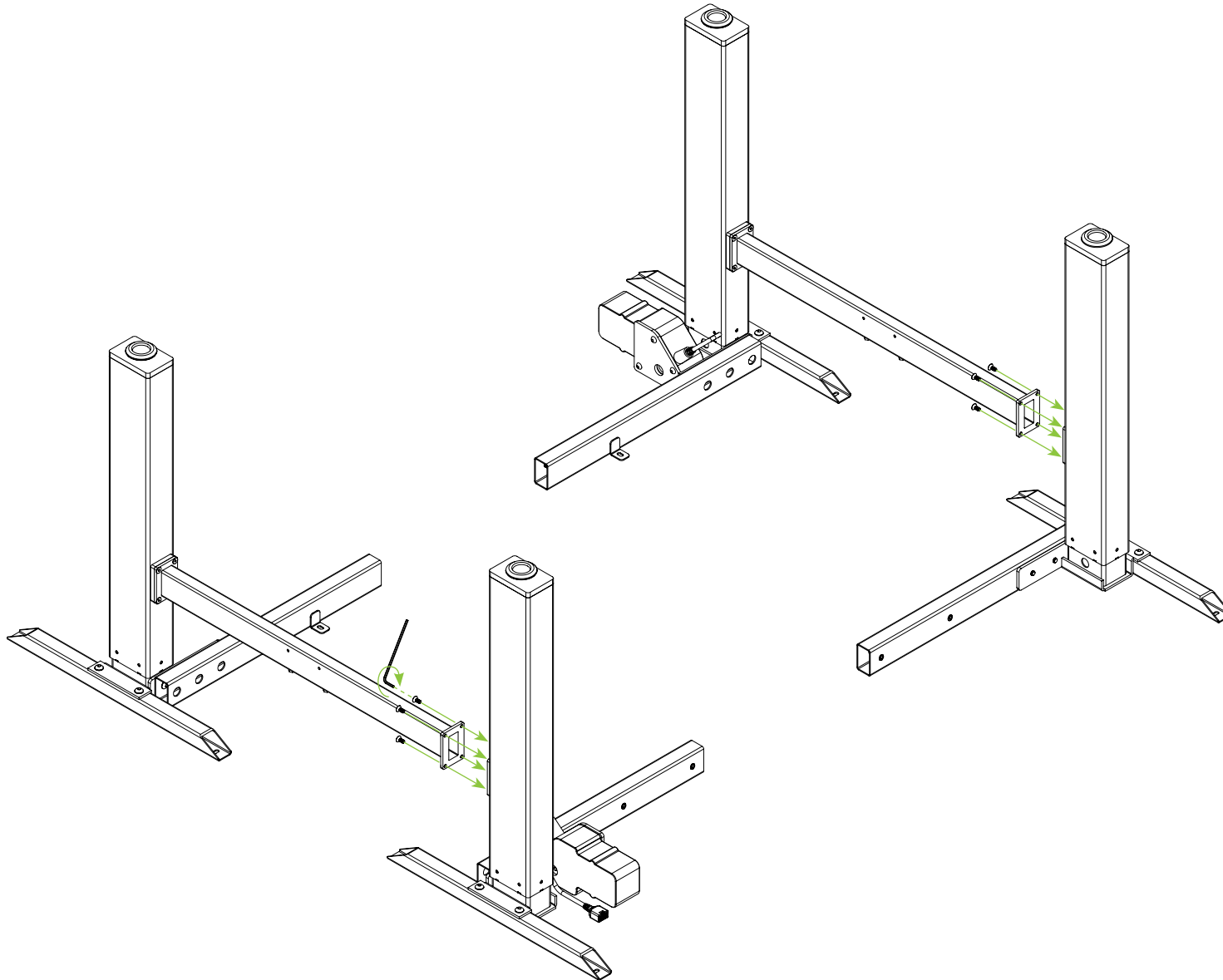

Step 5

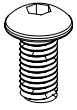

4 x M5x10

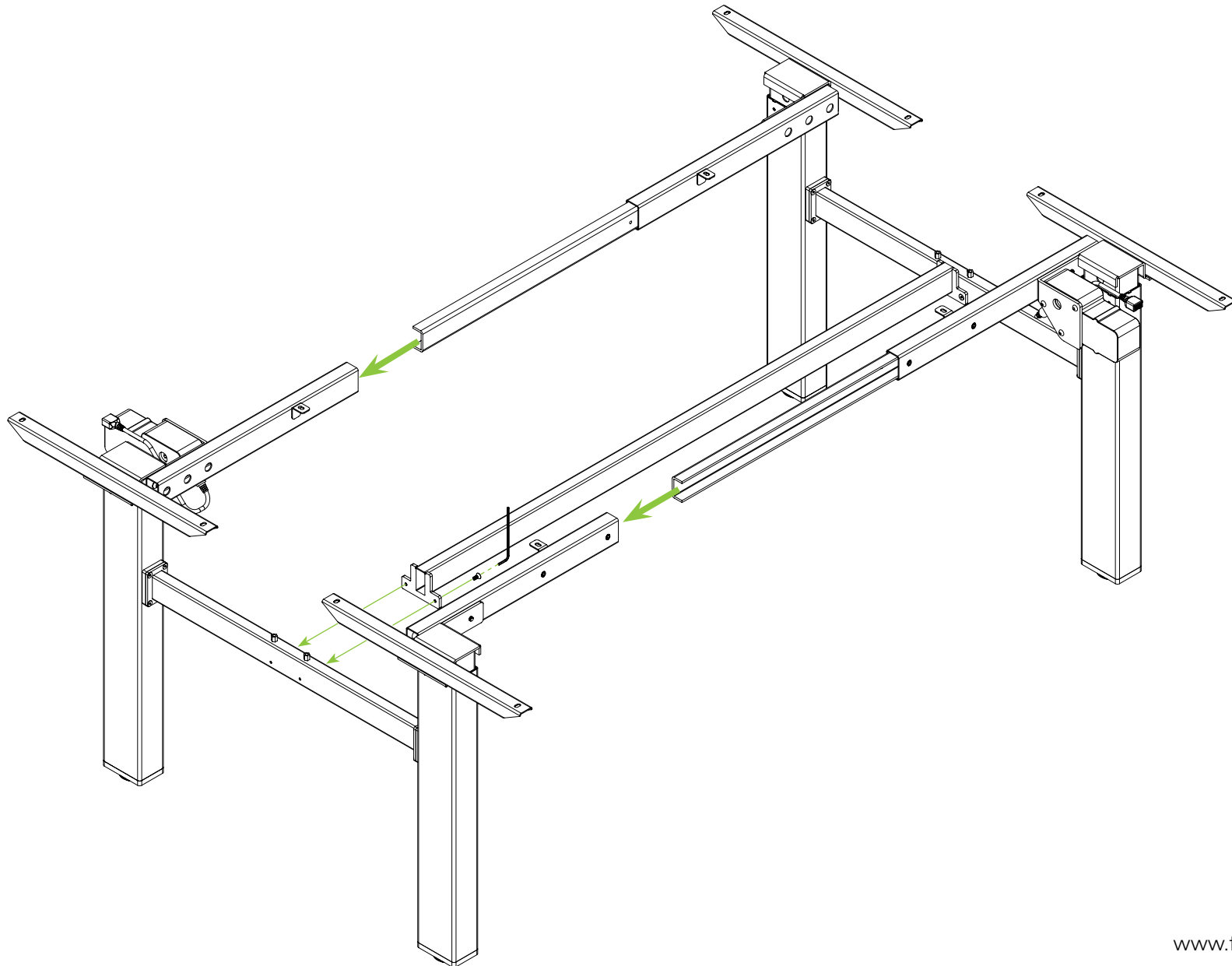

Step 6

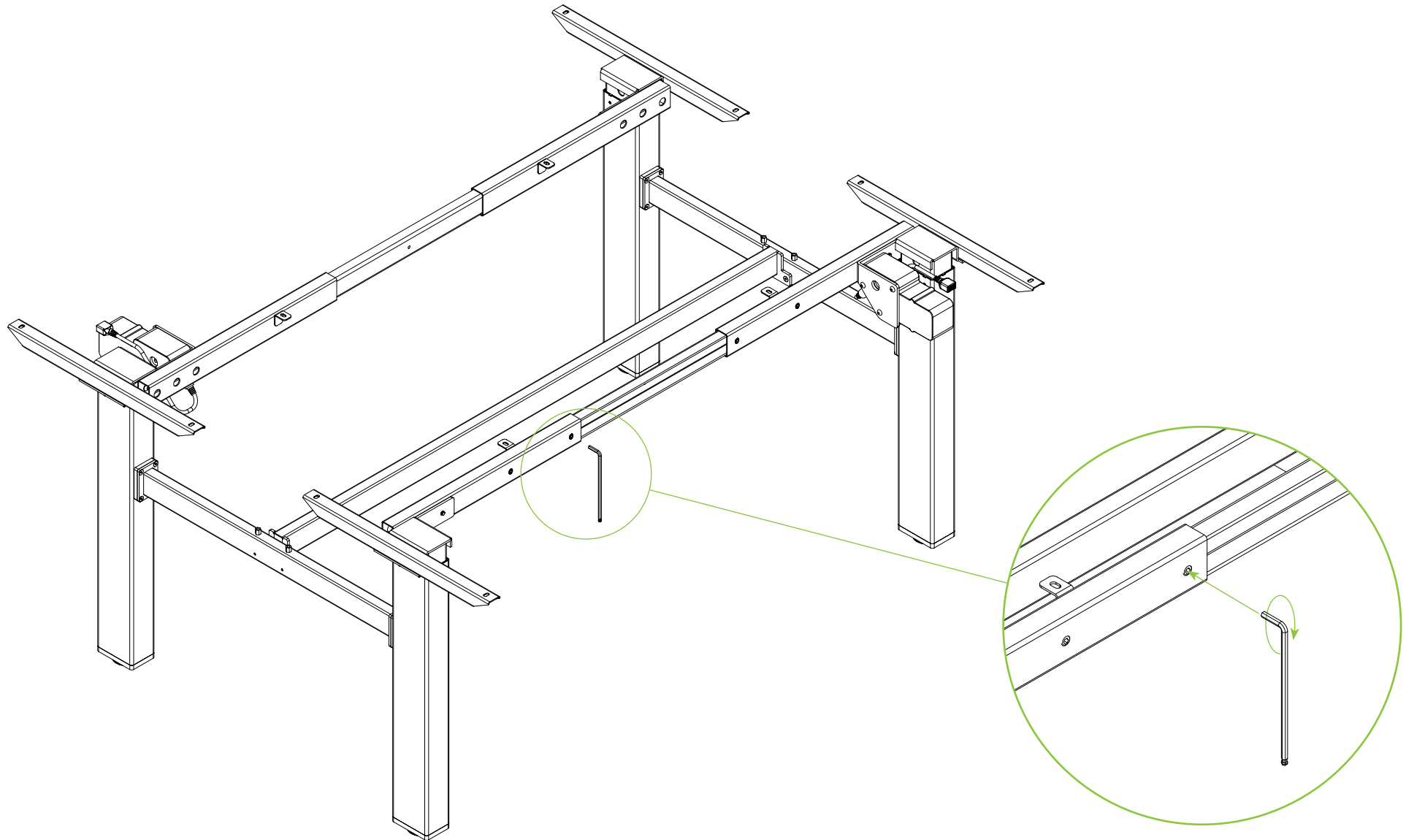

Step 7

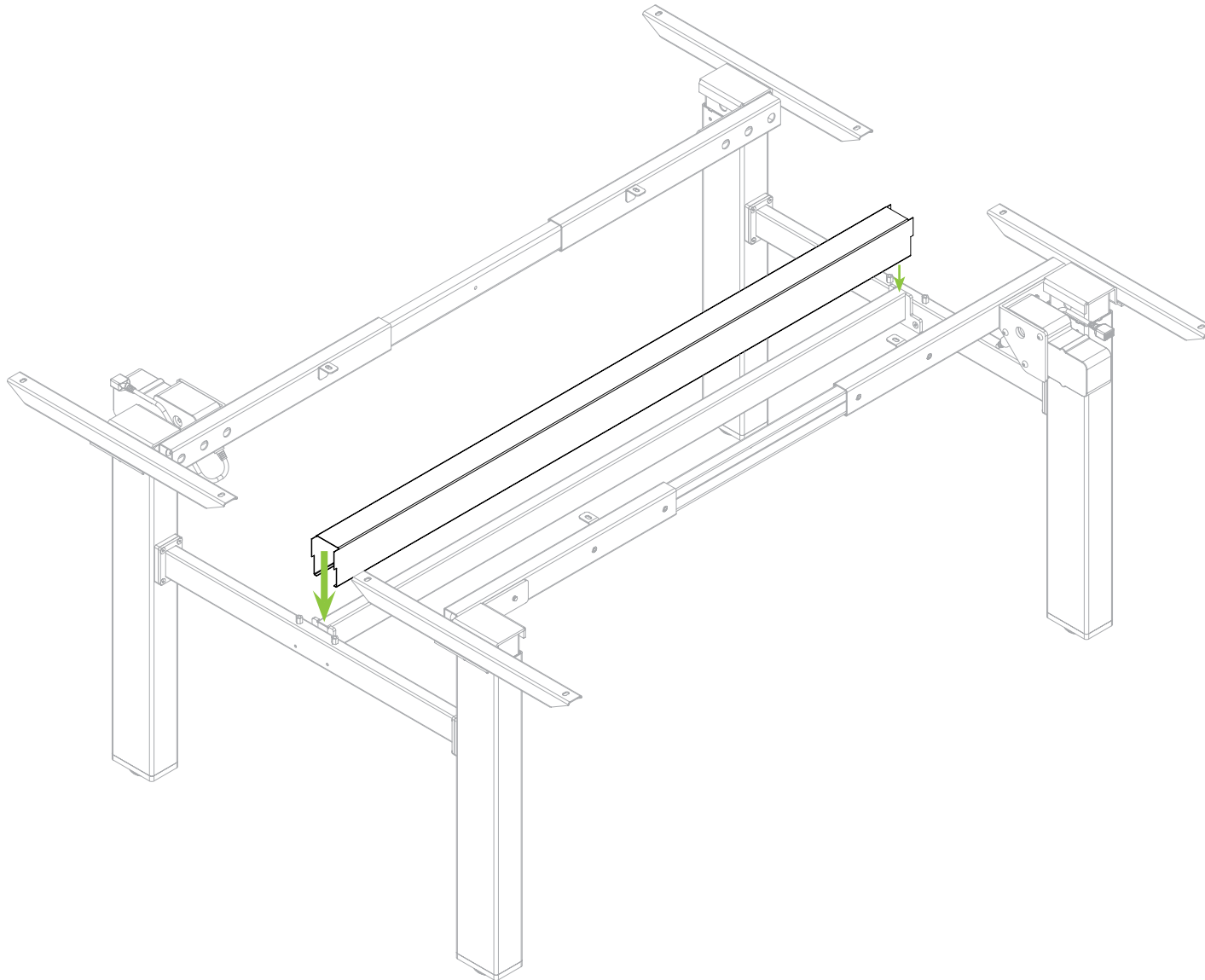

Step 8

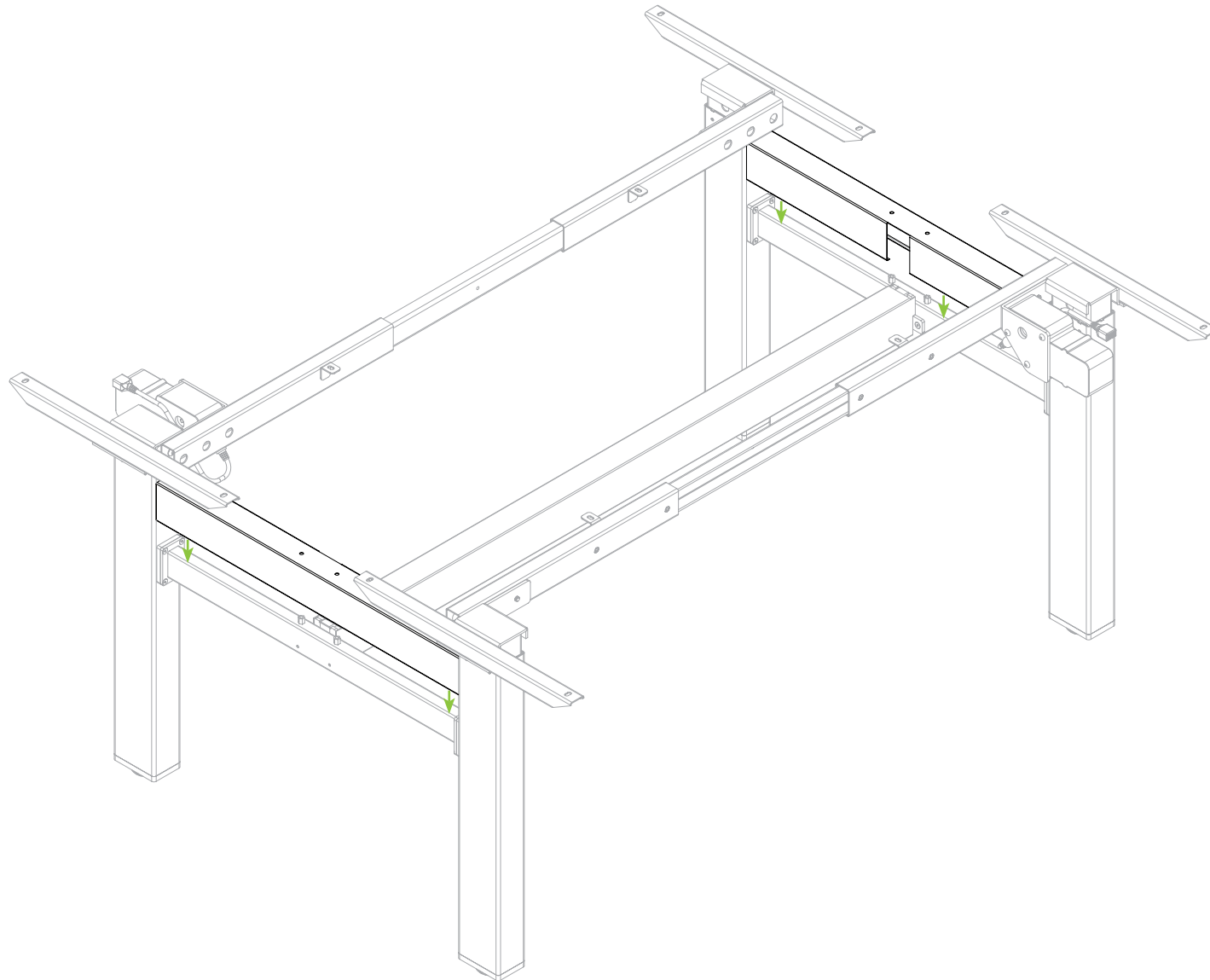

Step 9

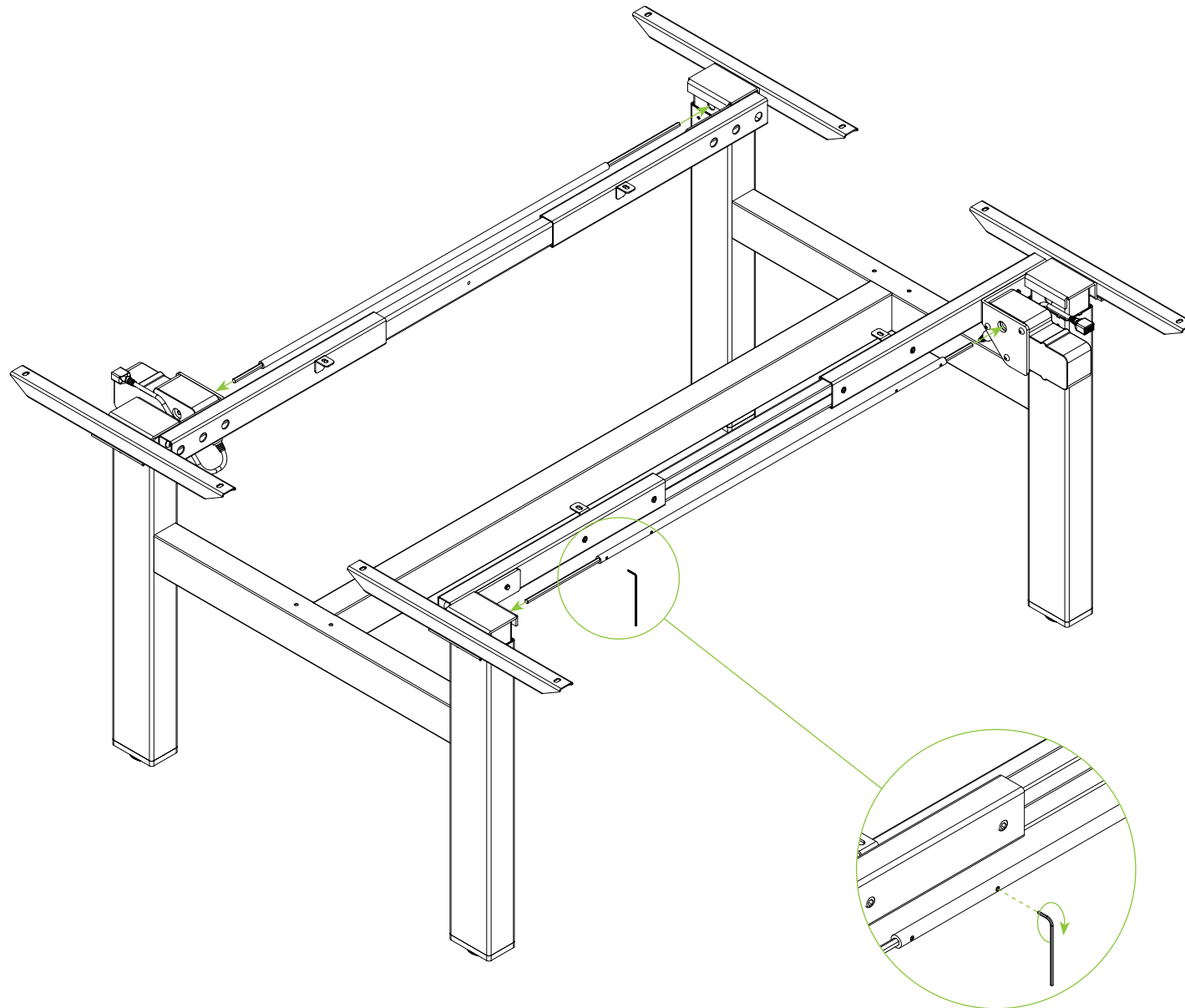

Step 10

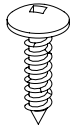

12 x ST5.0x23

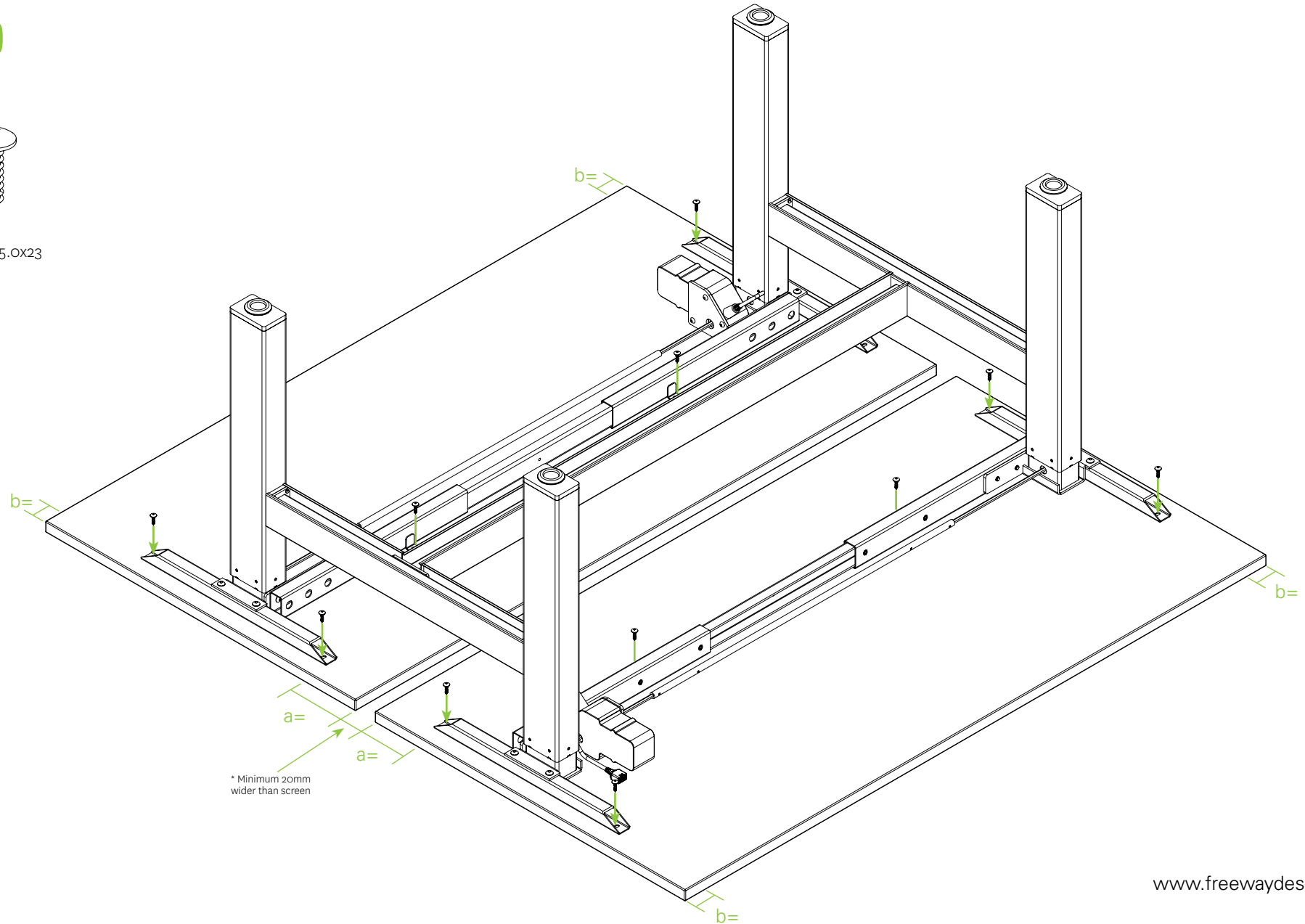

Step 11

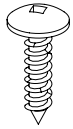

4 x ST3.9x13

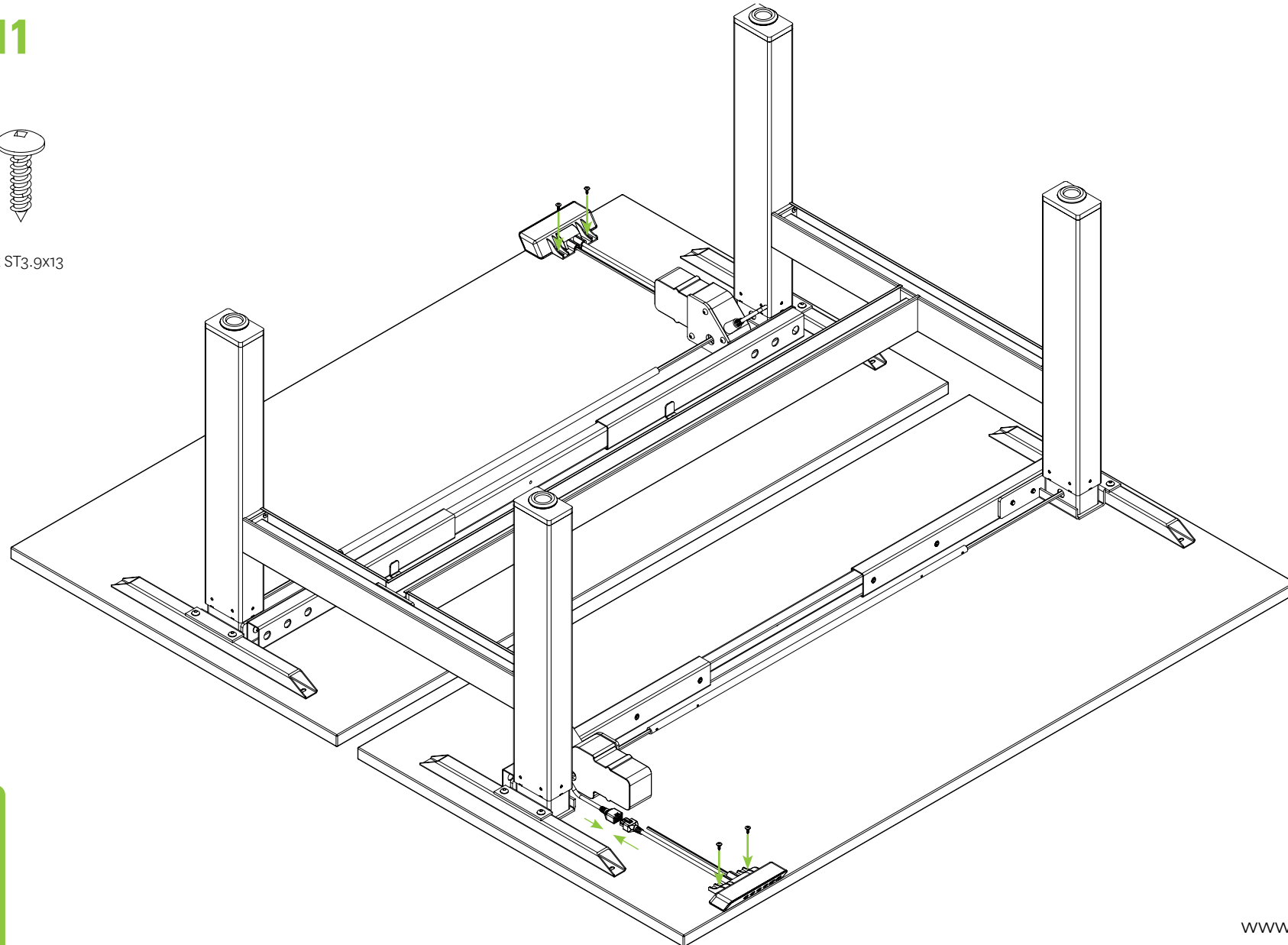

Optional Desk Hung Screen

Installation Guide

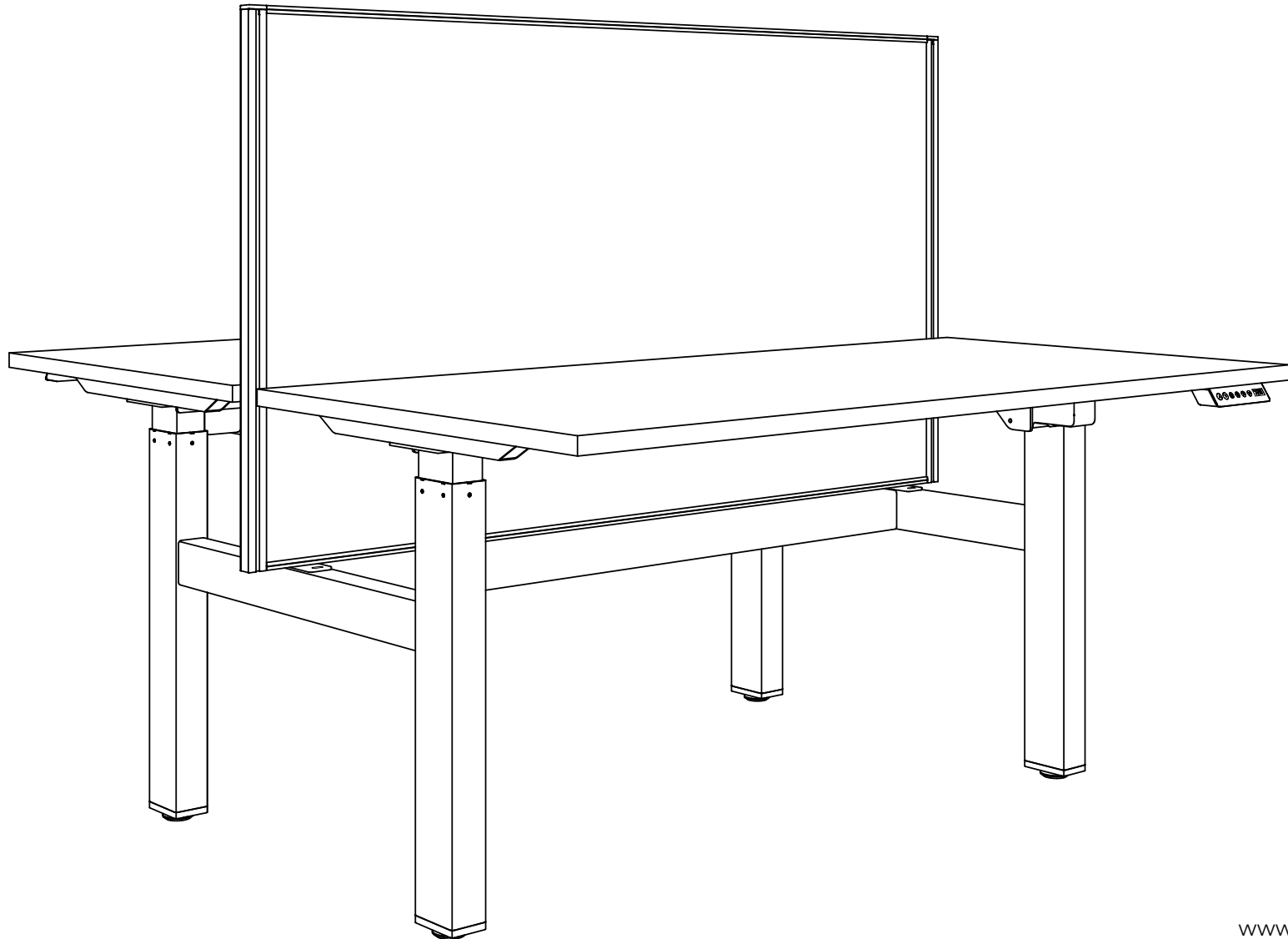

Optional Desk Hung Screen

Installation Guide - Electric 2 Column

Step 1

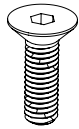

2 x M8x20

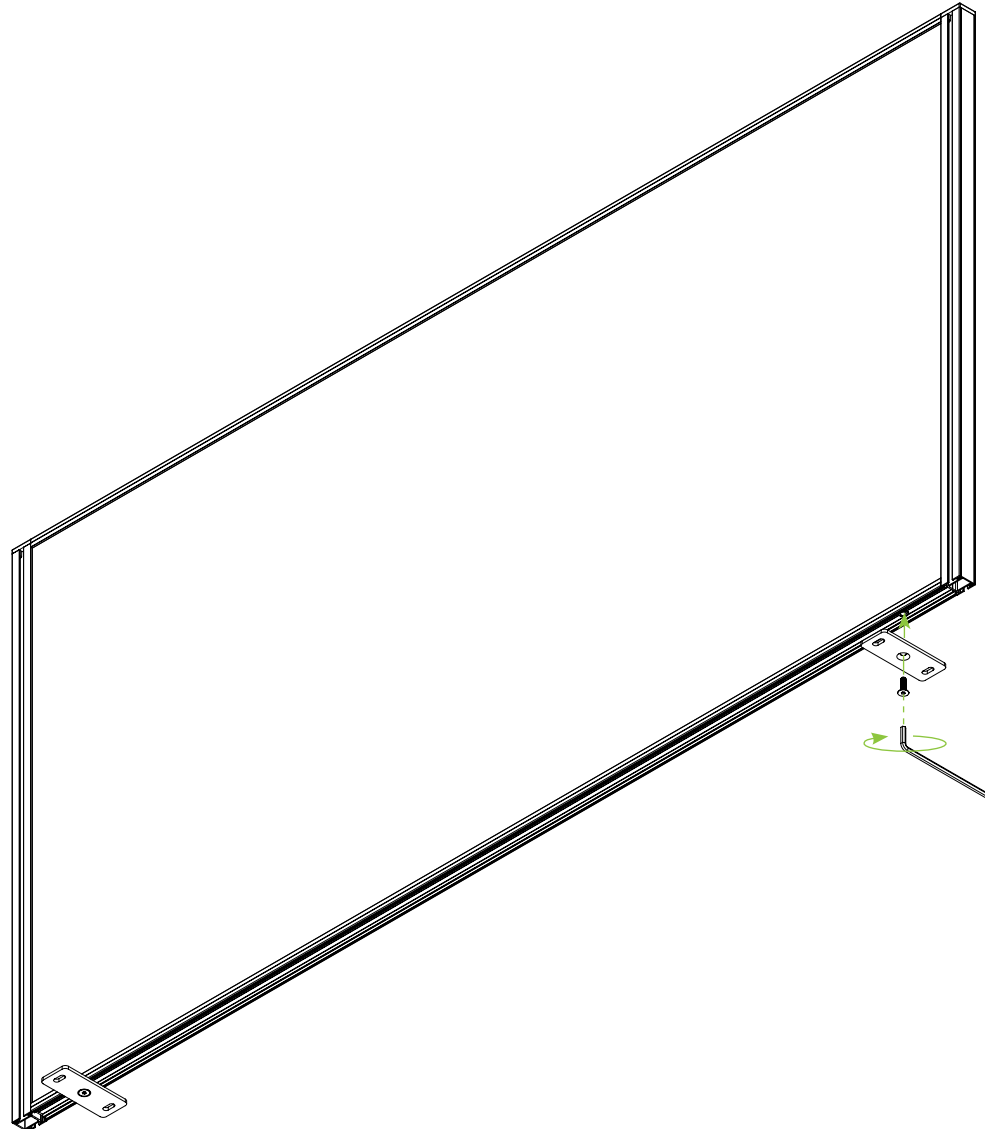

Optional Desk Hung Screen

Installation Guide - Electric 2 Column

Step 2

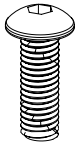

4 x M5x15

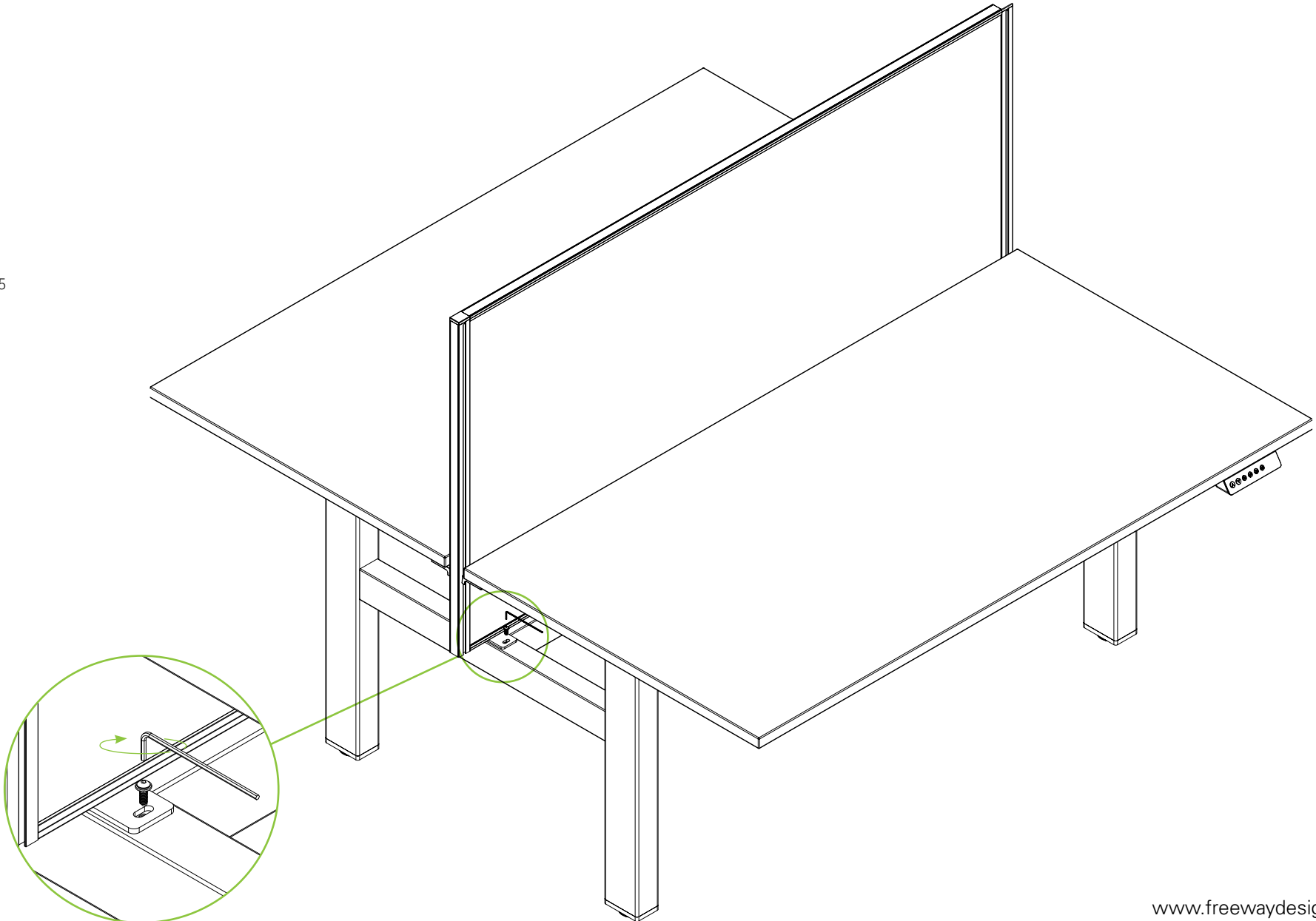

Optional Desk Hung Screen

Installation Guide - Electric 2 Column

Step 3

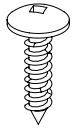

8 x ST5.0x23

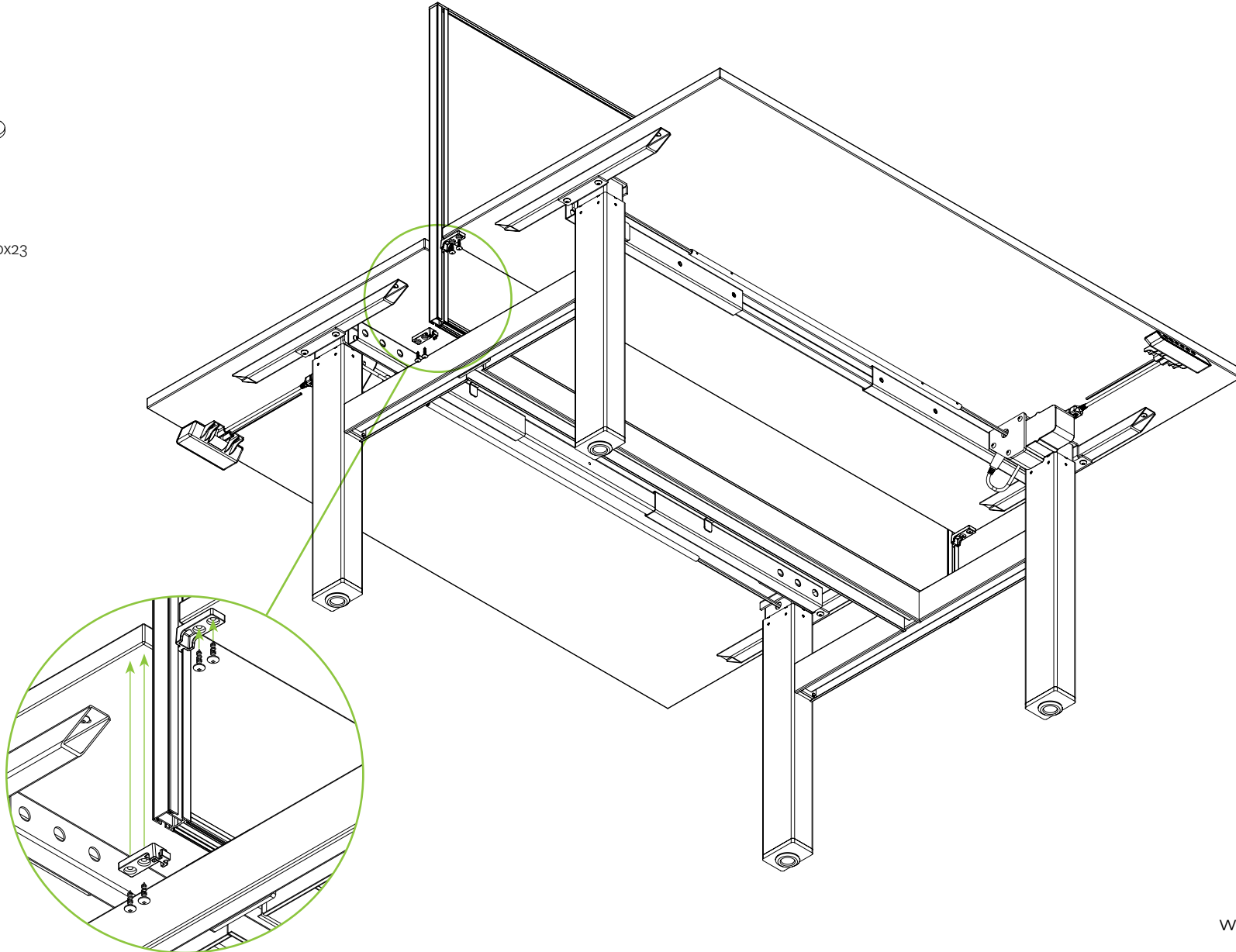

Optional Desk Hung Screen

Installation Guide - Electric 2 Column

Step 4

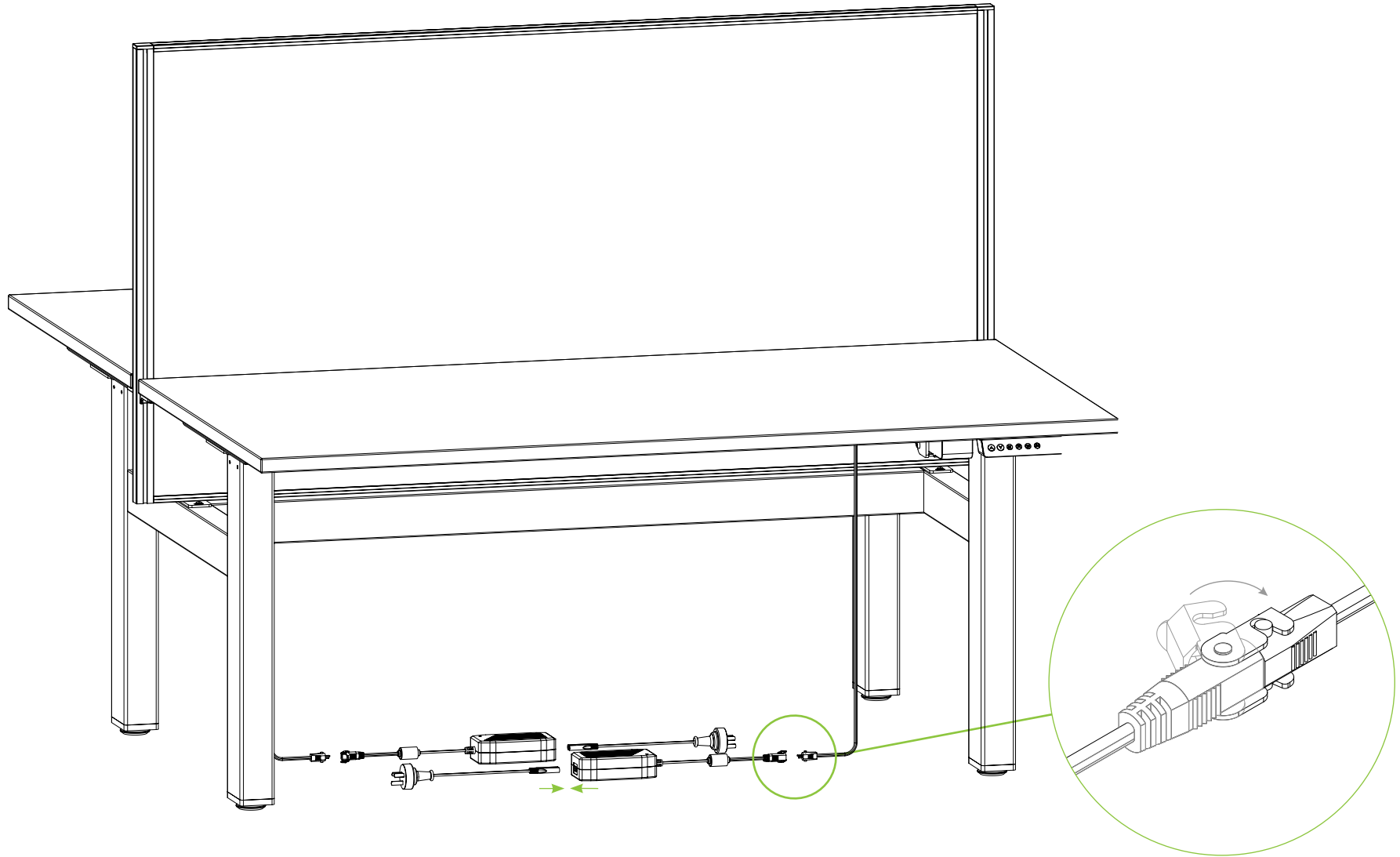

Optional Desk Hung Screen

Installation Guide - Electric 2 Column

Completed

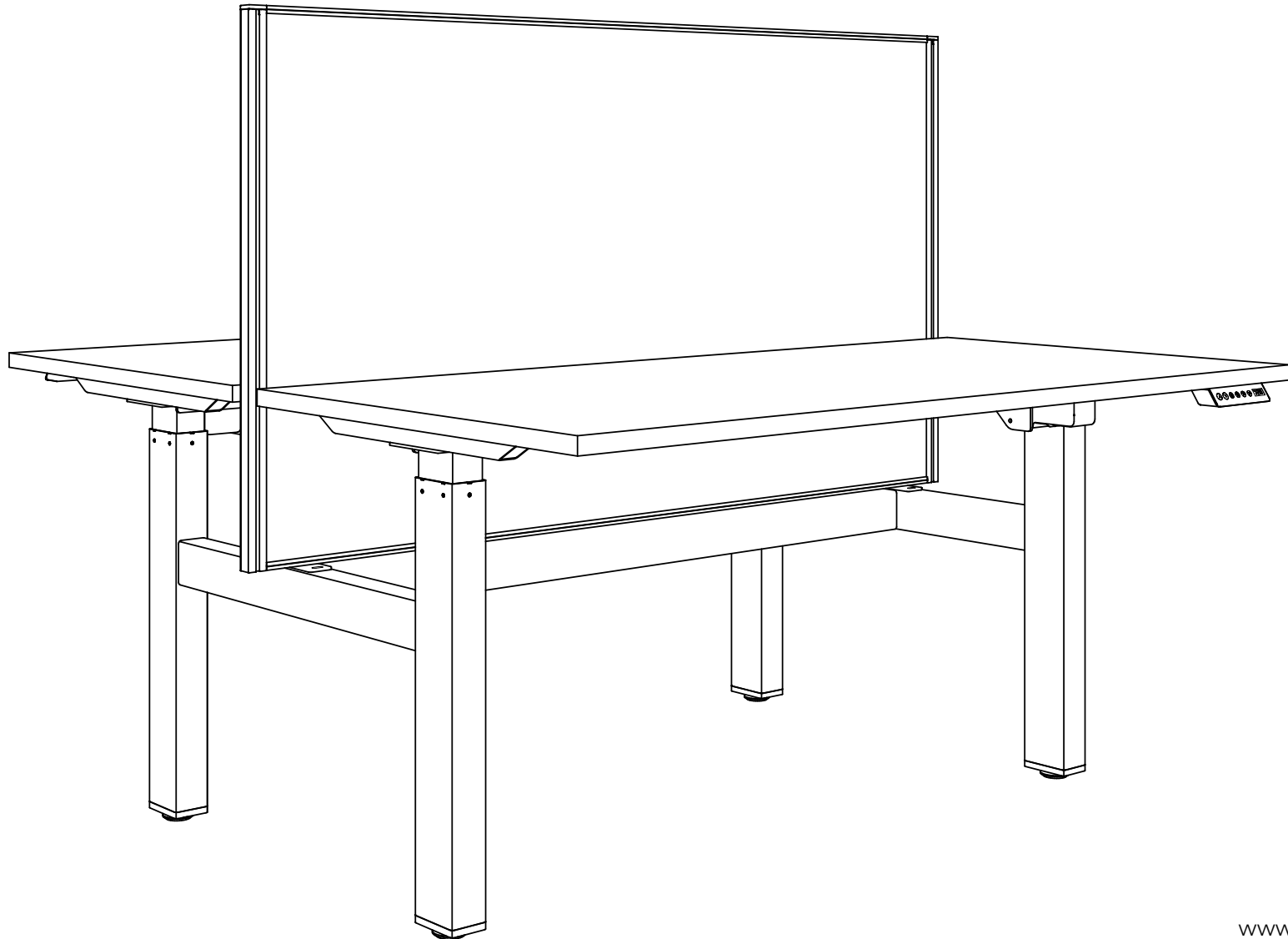

Optional Cable Tray

Installation Guide

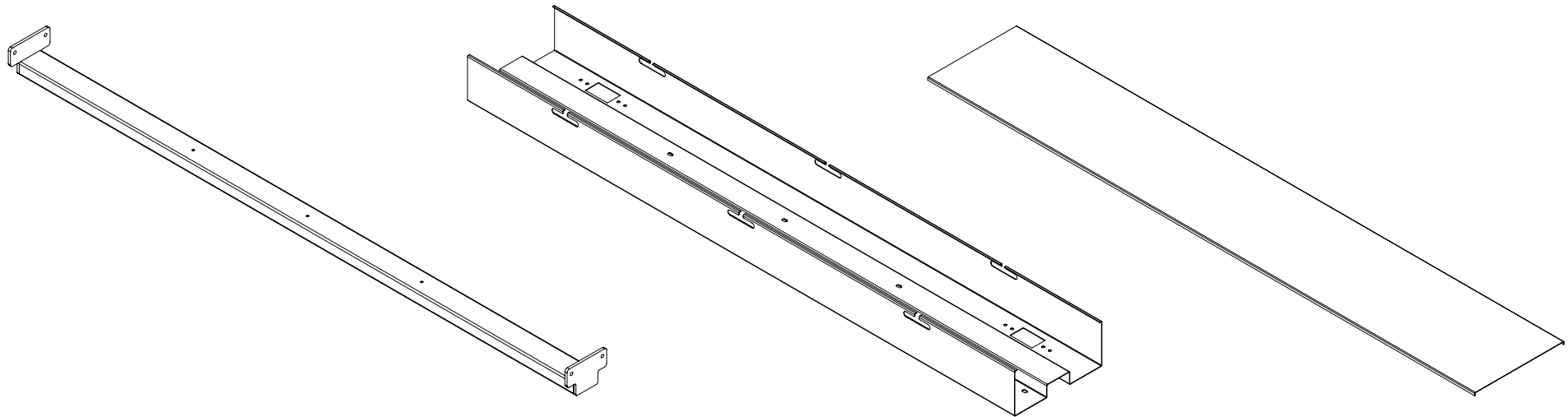

Optional Cable Tray

Installation Guide

Step 1

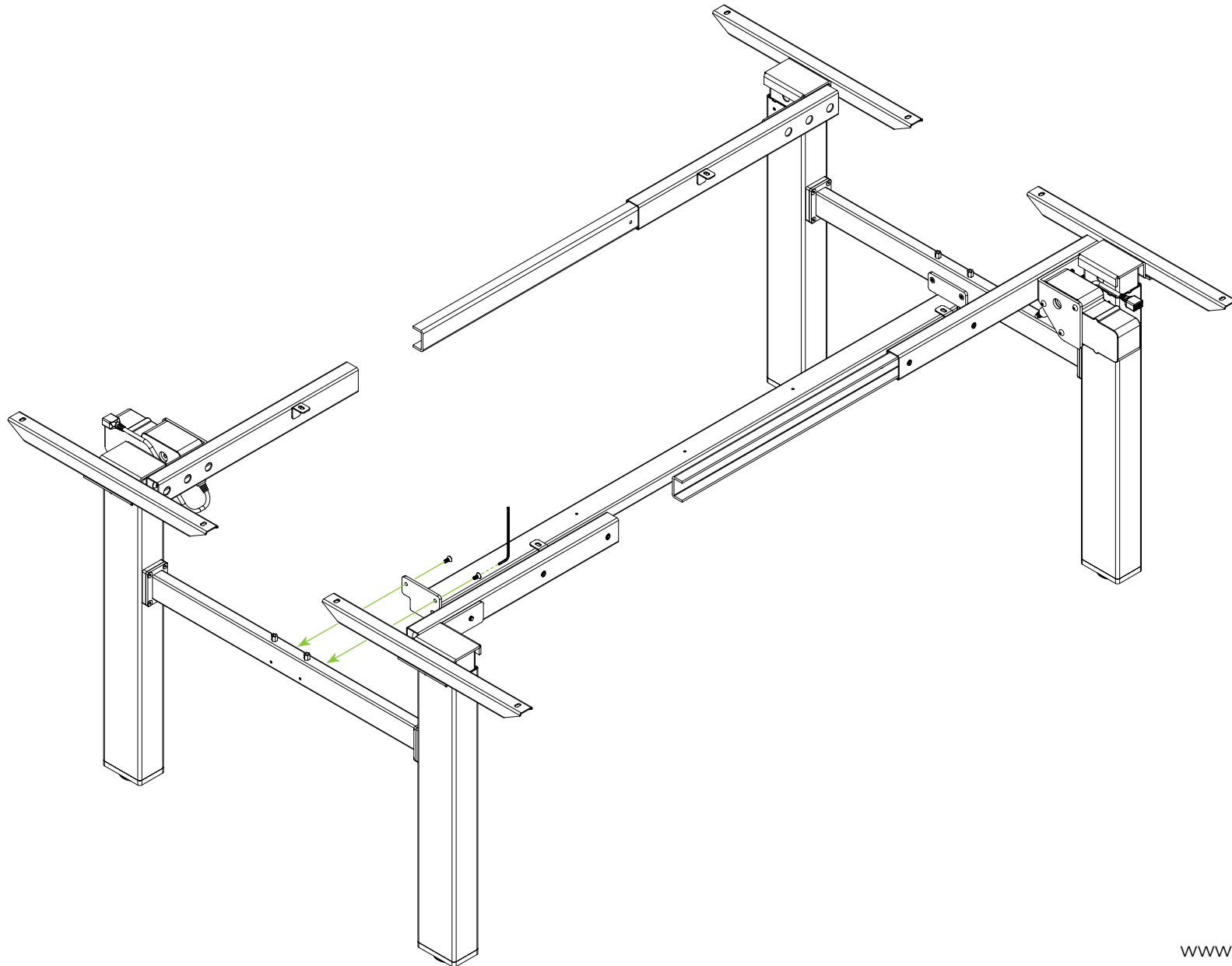

Optional Cable Tray

Installation Guide

Step 2

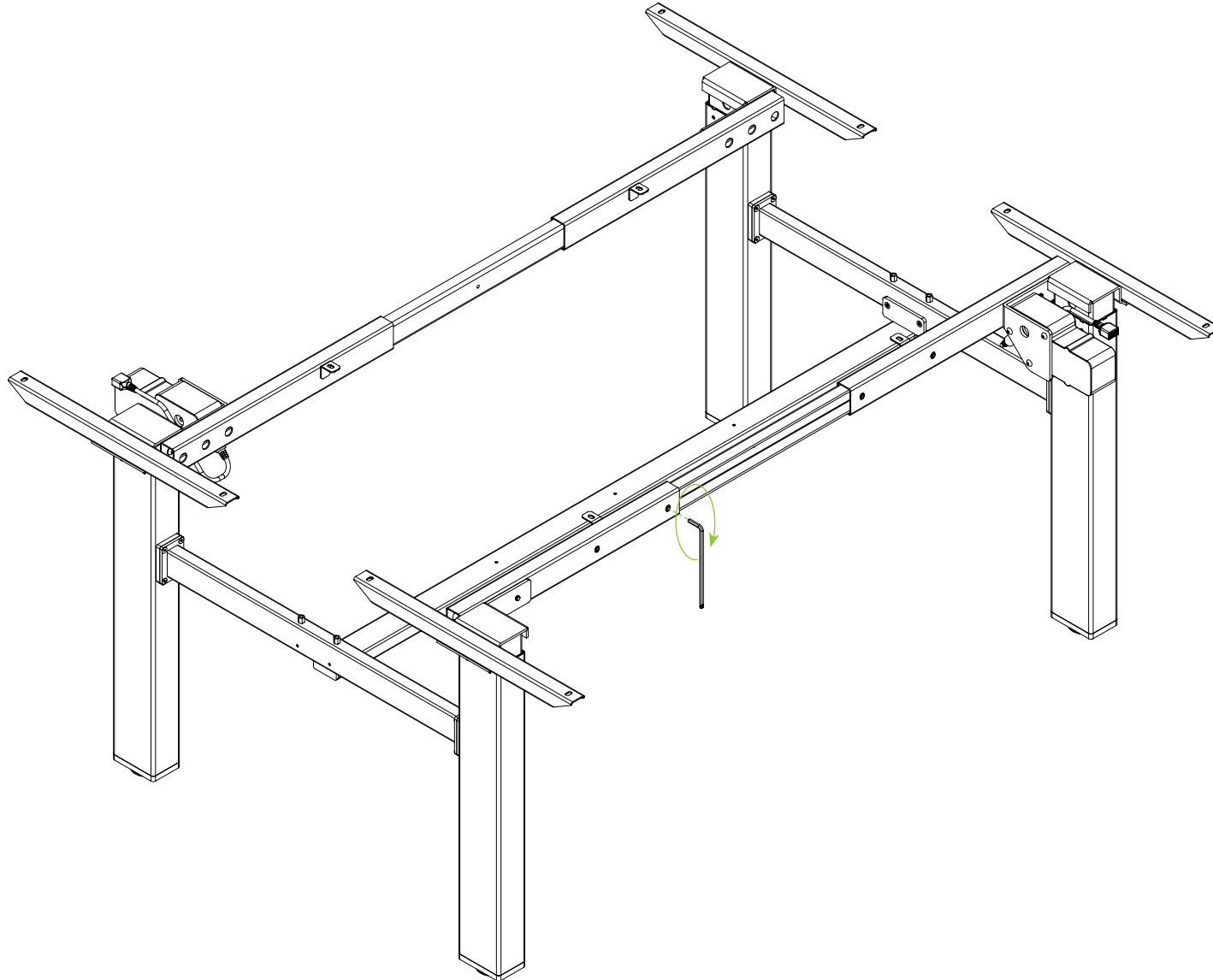

Optional Cable Tray

Installation Guide

Step 3

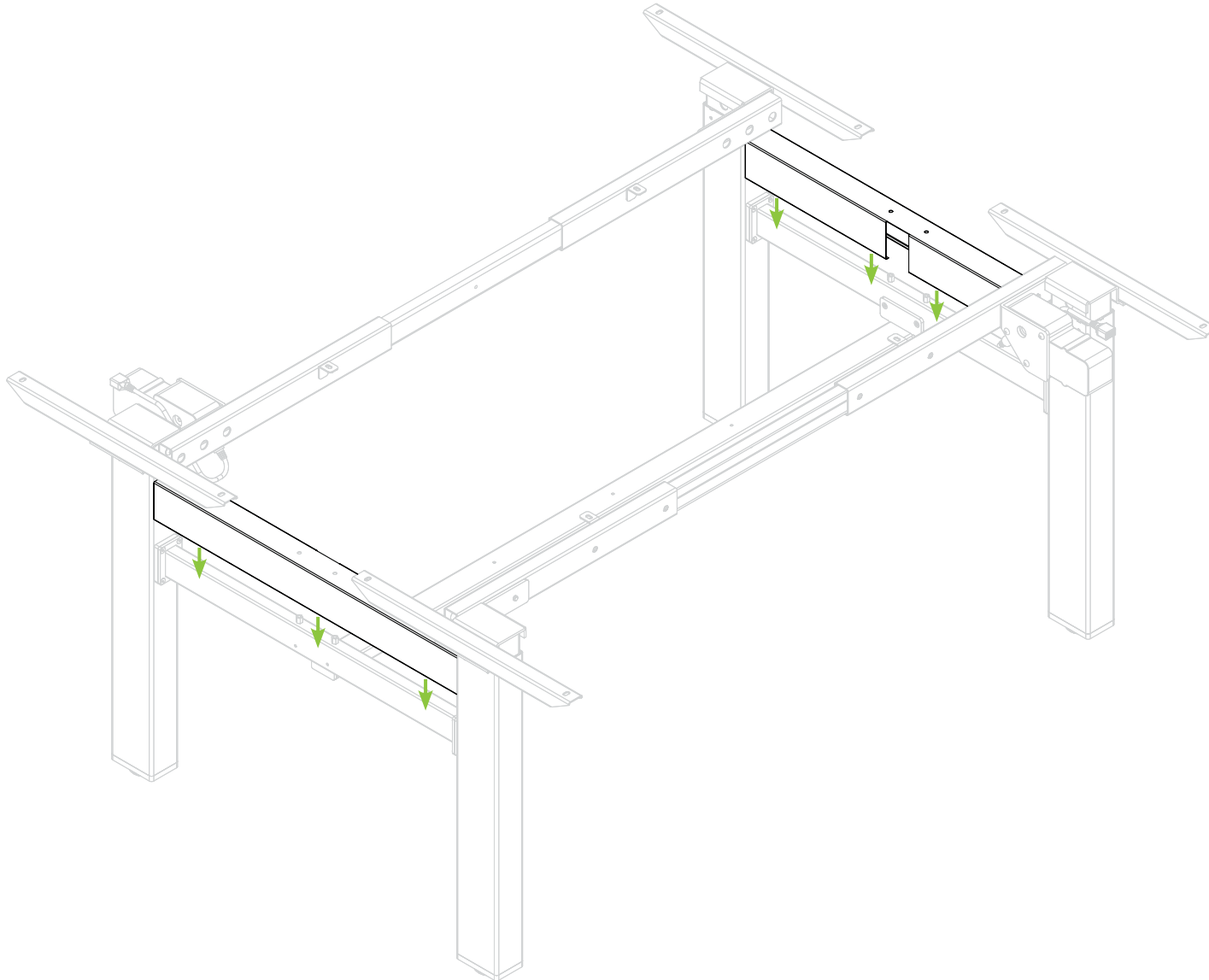

Step 4

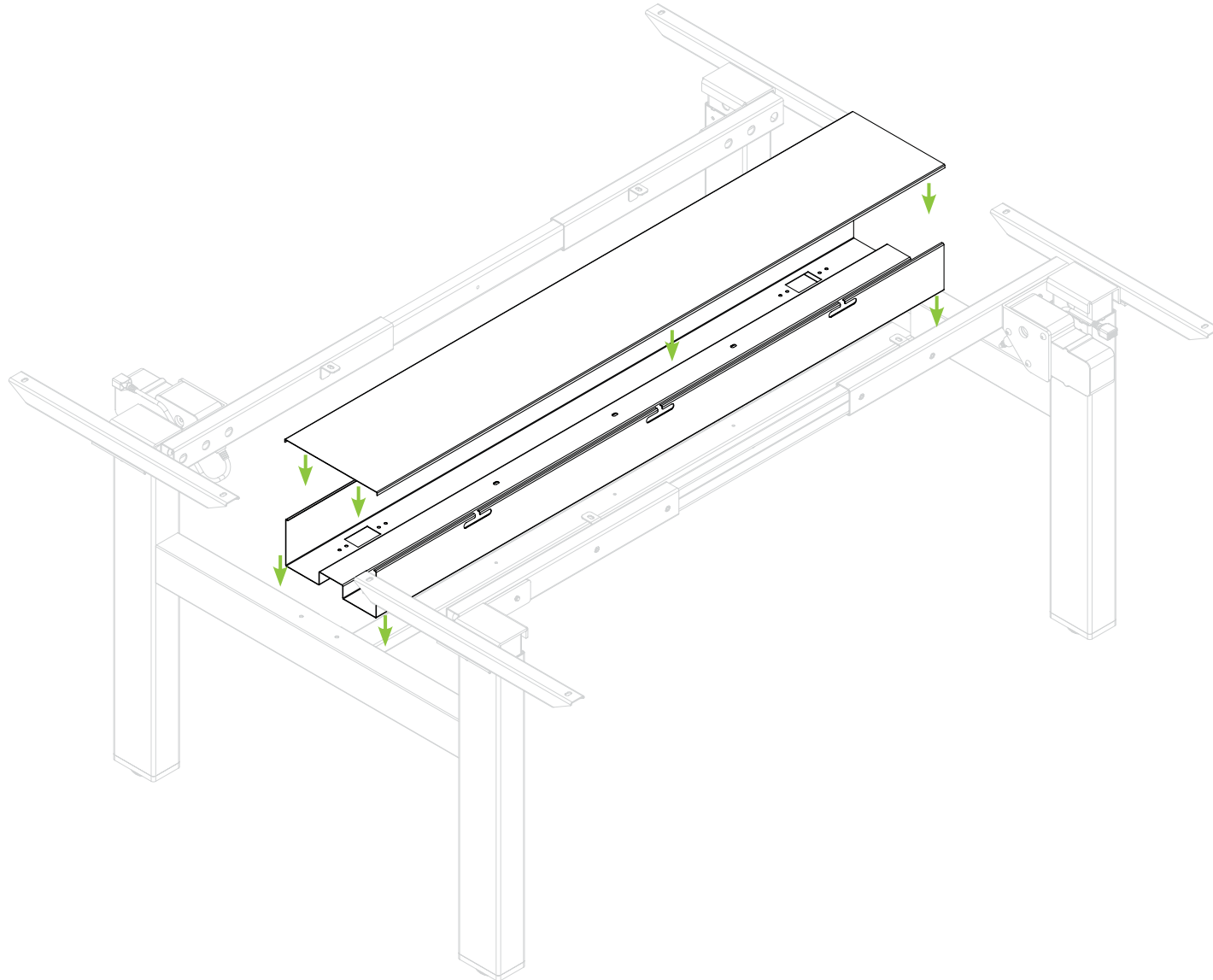

Directions For Use

IMPORTANT!

Please carefully read the assembly manual and direction for use prior to instalment, use and maintenance of the table frame to gain a complete understanding of its contents. It provides you with important information about the safety, use, installation and maintenance of the table.

WARNING: FAILURE TO COMPLY WITH OR OBSERVE ALL ASSEMBLY, SAFETY AND OPERATION INSTRUCTIONS REGARDING THE USE OF THIS PRODUCT MAY RESULT IN SERIOUS BODILY INJURY.

SAFETY

- The table must be used in a safe manner. Inappropriate use may cause damage to the table and/or cause bodily harm to the user or persons nearby.
- Do not tamper with electrical components as this may lead to serious bodily harm.
- Only connect the electric table frames to the prescribed mains power voltage.
- Do not use the table frame to lift people.
- Please retain this operation manual and pass it on to any future owner.

USAGE

- The height-adjustable table is designed for use in dry work environments only.
- The table height is infinitely adjustable within its height range so that it can be set to the user's most ergonomic working height. The user should seek professional help to establish their optimum working height.
- The table has been designed as a devise to elevate the users work surface and associated office peripherals. Do not use the table frame for any other purposes than that which it has been designed for. Any other use is at user's own risk!
- Do not crawl, lie or move around under the table frame, and do not sit or stand on the table frame.
- CHILDREN should only use the table when supervised by adults.
- Liability: The manufacturer accepts under no circumstances warranty claims or liability claims for damages arising from improper use or handling of the table frame other than that described in this operation manual.

SET UP AND INSTALLATION

Assemble the table frame according to the assembly instructions on pages 4 - 12.

- Place the table in a safe distance from window frames, radiators, furniture etc. so that persons cannot become trapped.
- Level the table with the adjustable feet ensuring that the table is stable.
- Check that no cables can get jammed.
- Connect the table to the 110 or 230 VAC power outlet.

The table is now ready for use.

MAINTENANCE

- The table does not require any maintenance by the user
- The table is only to be cleaned with a wrung cloth.

TECHNICAL DATA

Height Range: 680-1130mm including worktop

Speed: ~22mm/s

Input Voltage: 100-240V AC 50-60Hz

Output Voltage: 24V DC 2.0A

Duty Cycle: 10% 2min on 18min off

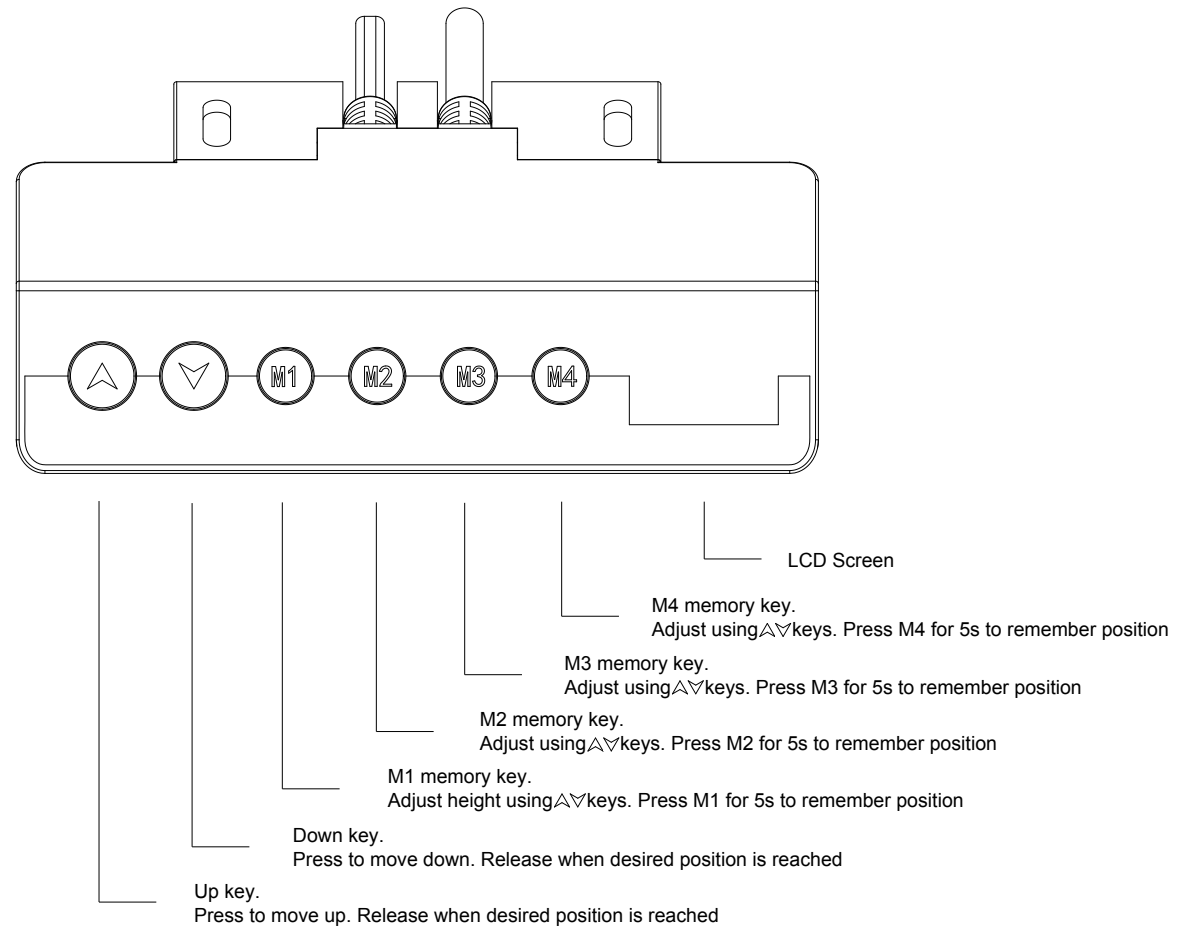



freeway

Agile

Installation Guide - Electric 3 Column

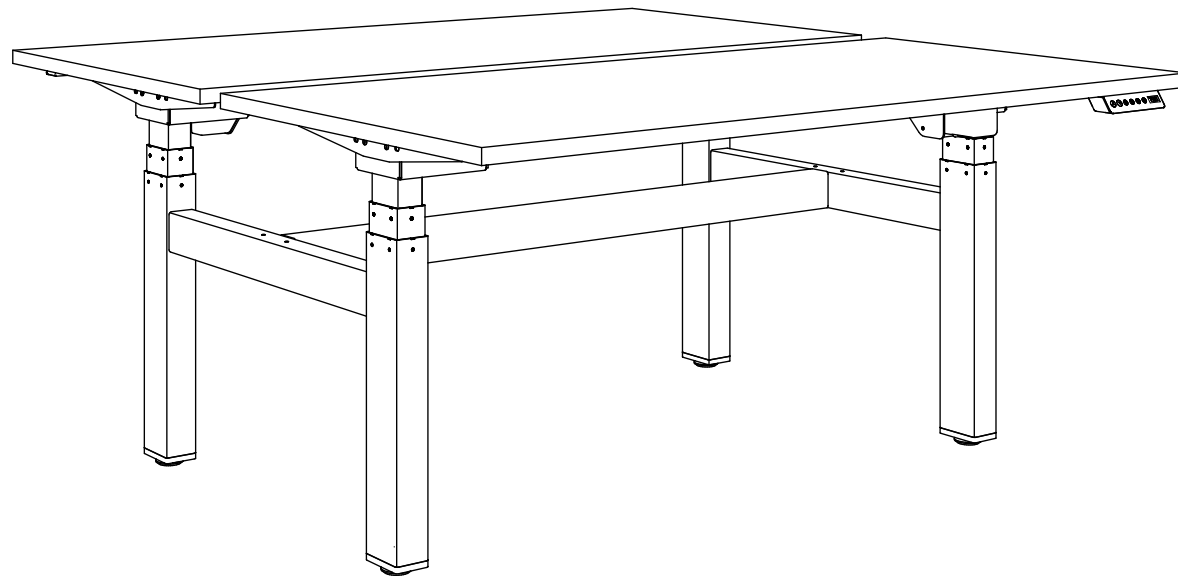

Parts:

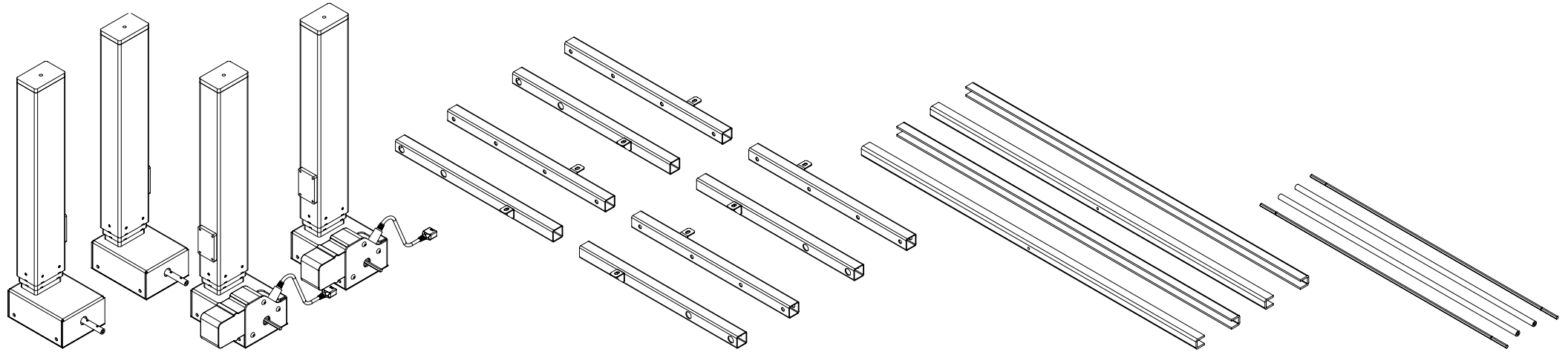

2 x L&R Leg Pair

4 x L&R Leg Rail Pair

4 x Cross Rail

1 x Drive Shaft

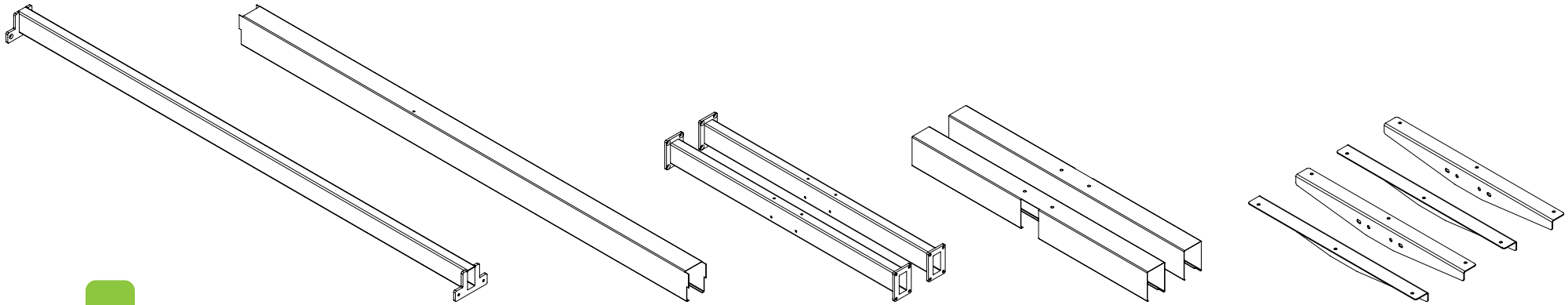

1 x Cross Beam

1 x Cross Beam Cover

2 x Leg Beam

2 x Leg Beam Cover

2 x L&R Support Bar Pair

Parts:

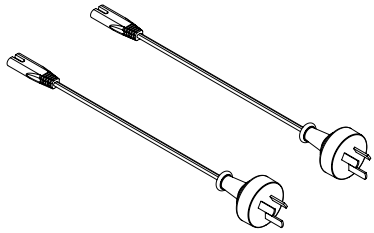

2 x Power Cord

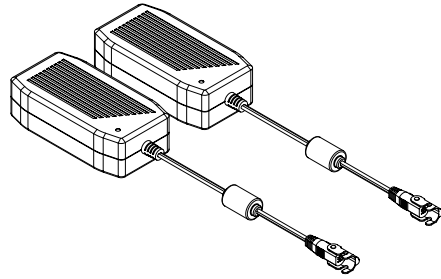

2 x Power Supply

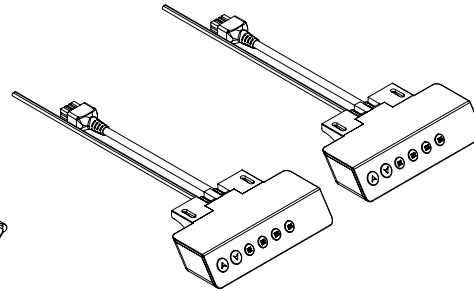

2 x Handset

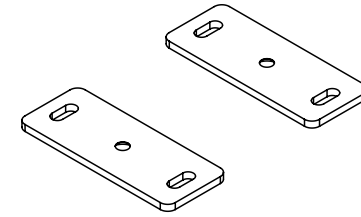

2 x Screen Bracket

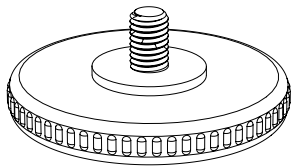

4 x Levelling Foot



24 x M8x10

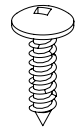

24 x ST5.0x23



4 x ST3.9x13

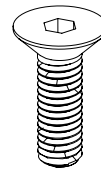

2 x M8x20

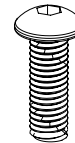

4 x M5x15



20 x M5x10

Step 1



16 x M8x10

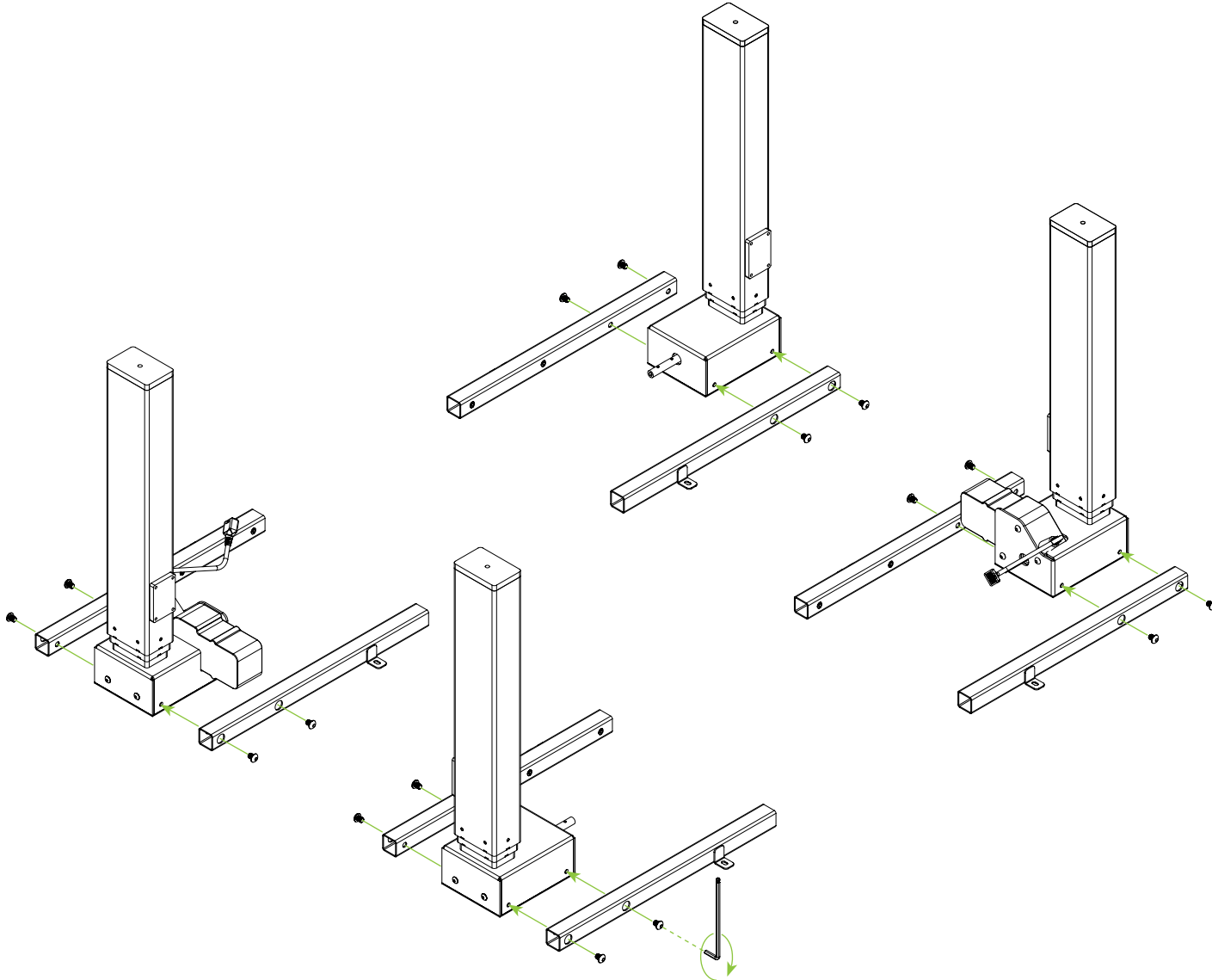

Step 2



8 x M8x10

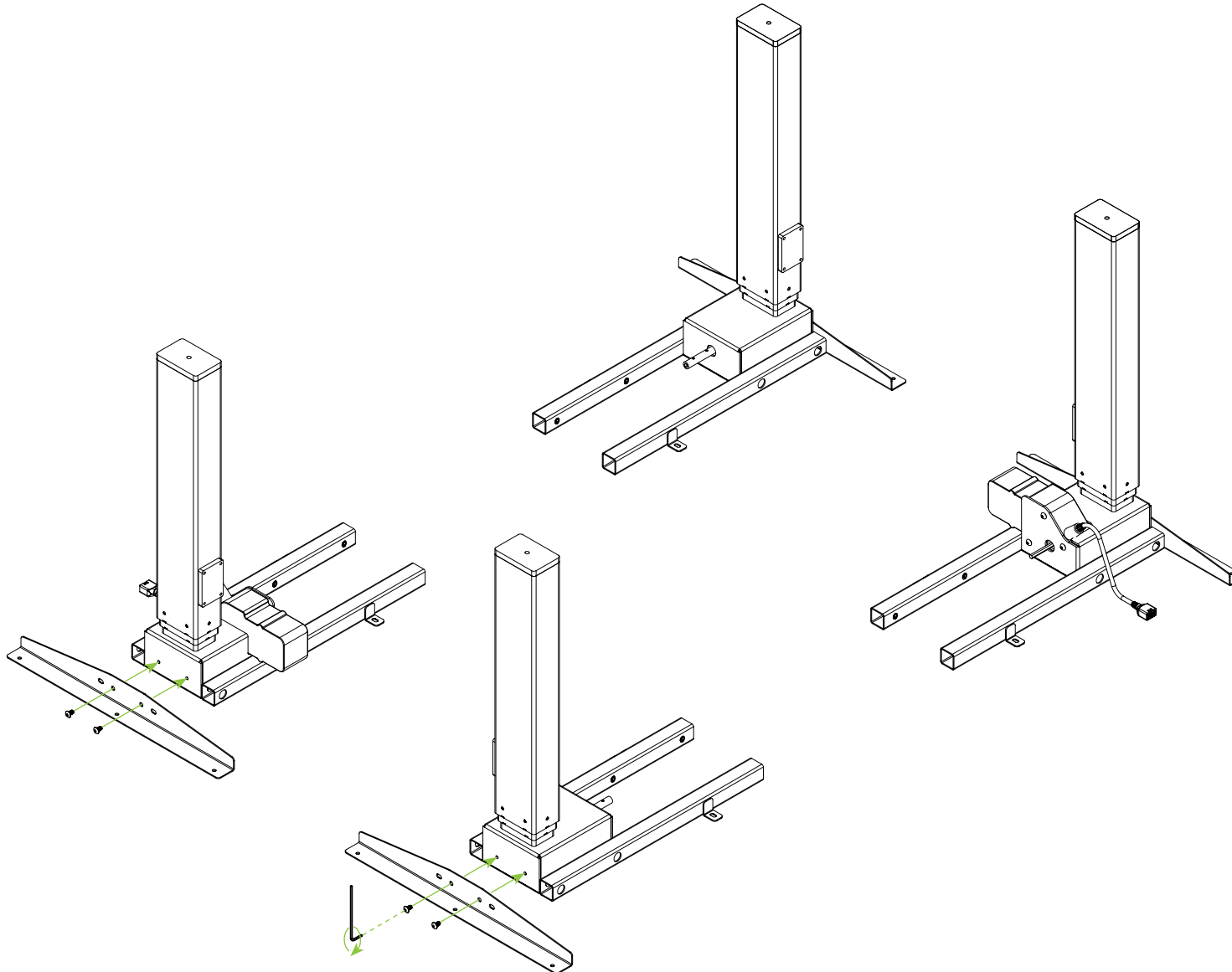

Step 3

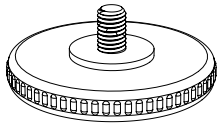

4 x Adjustable Glide

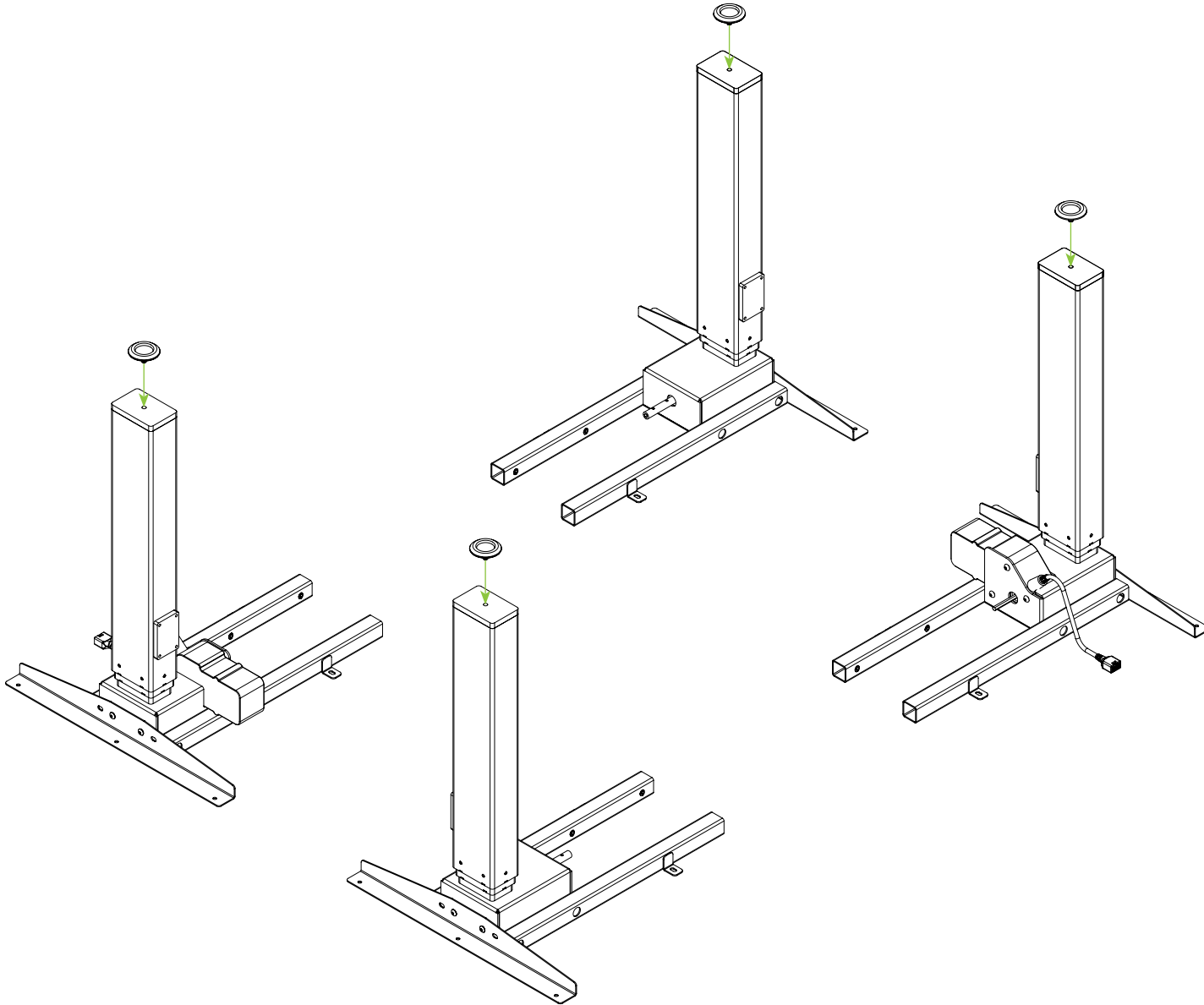

Step 4

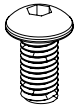

16 x M5x10

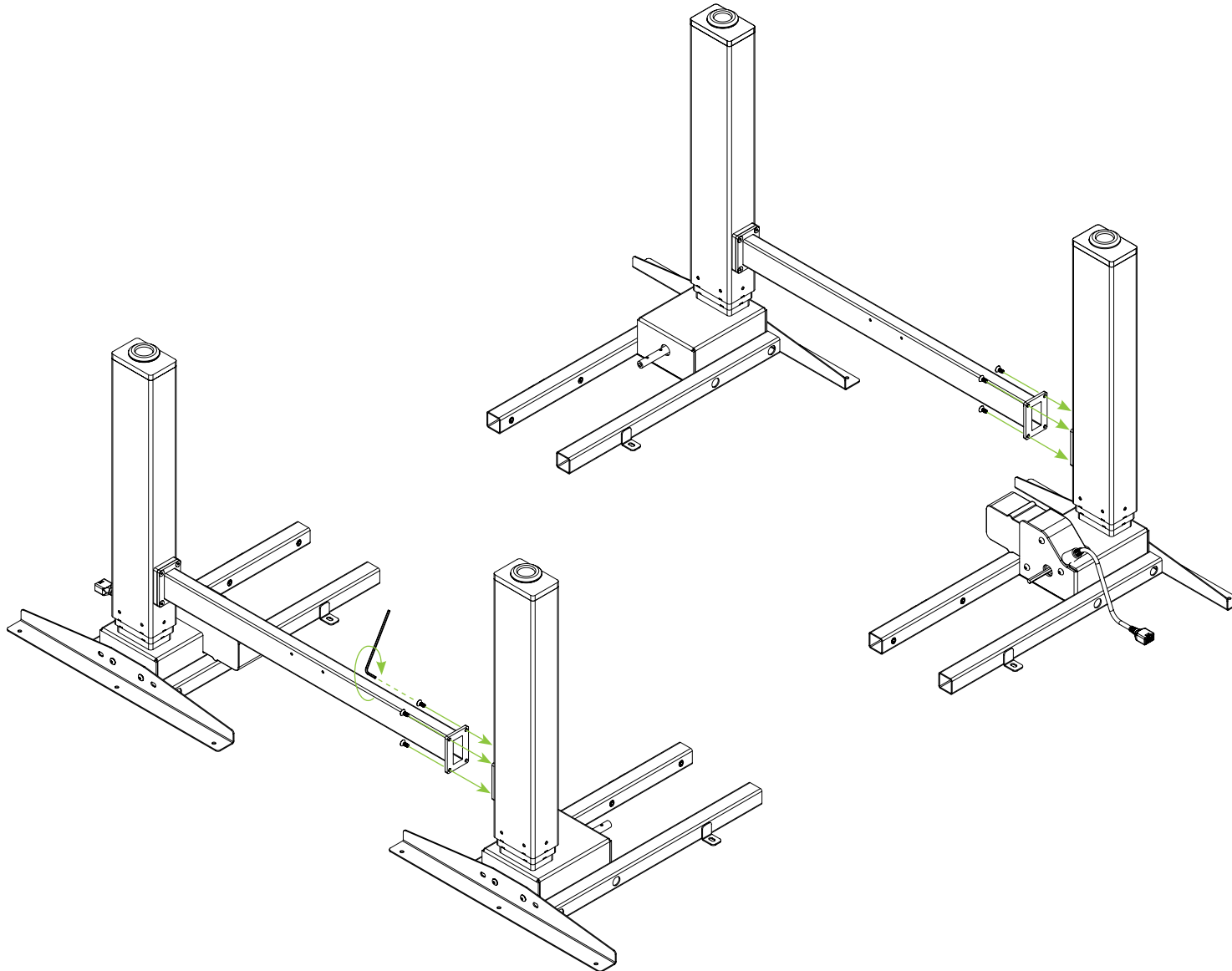

Step 5

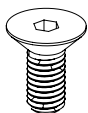

4 x M5x12

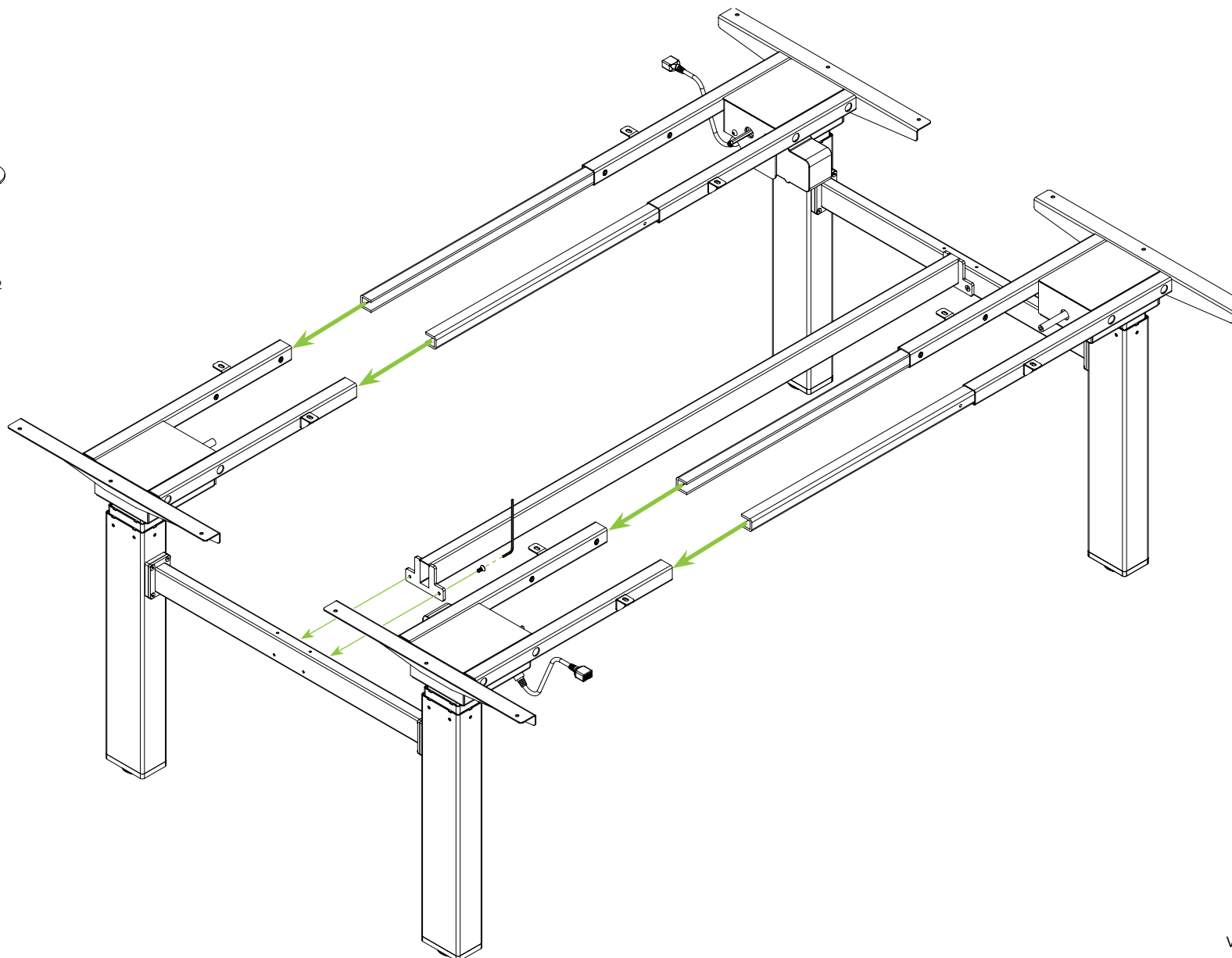

Step 6

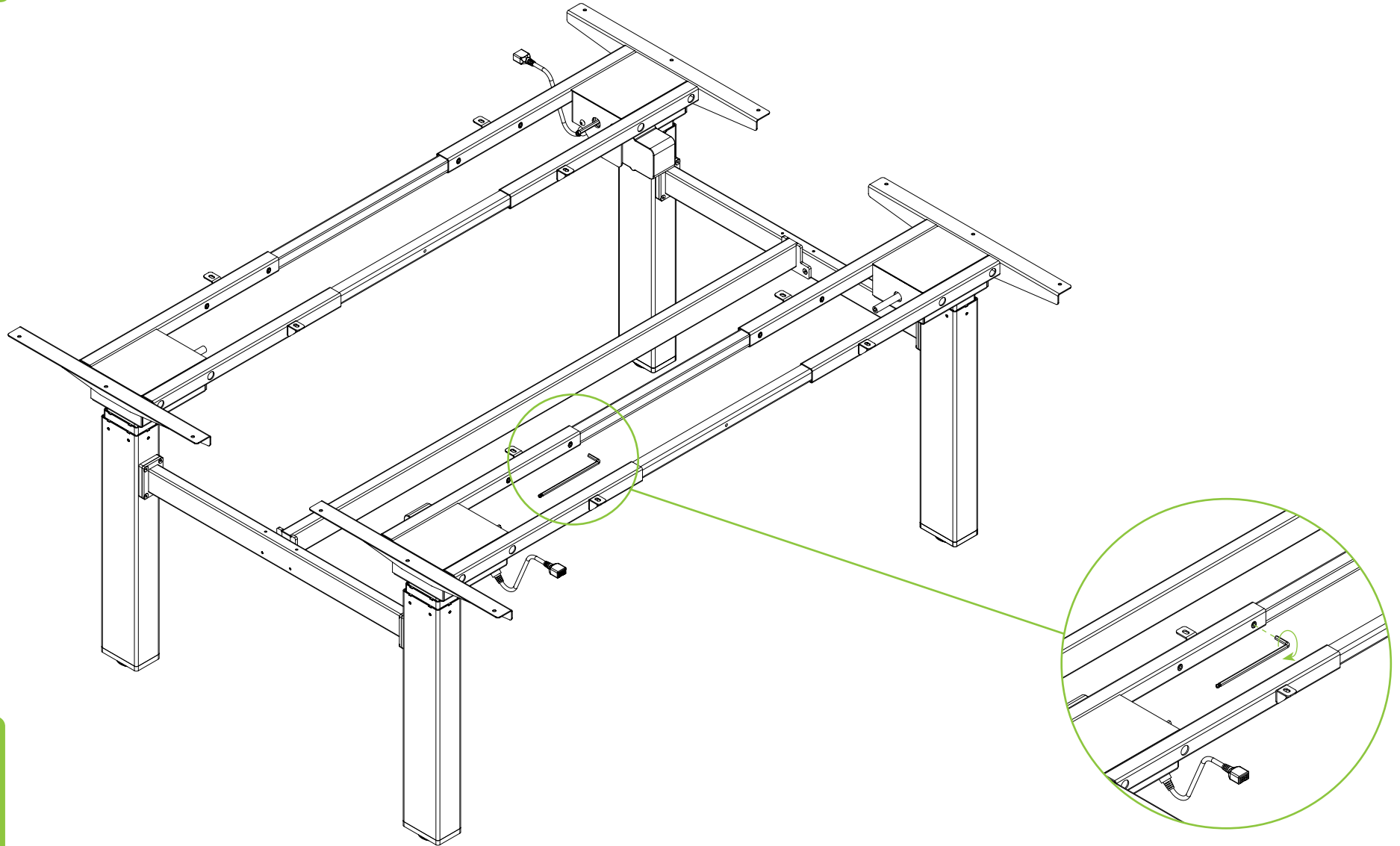

Step 7

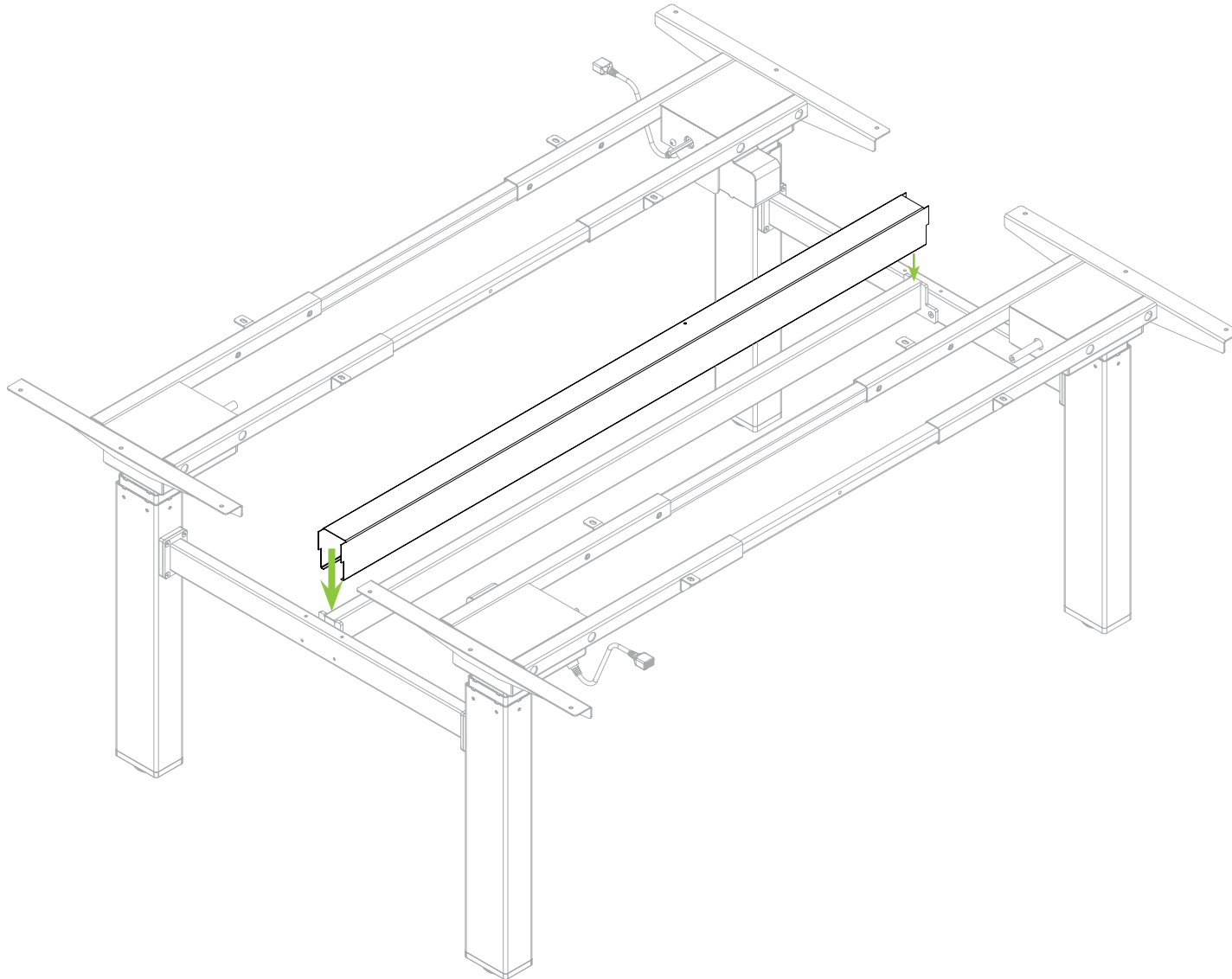

Step 8

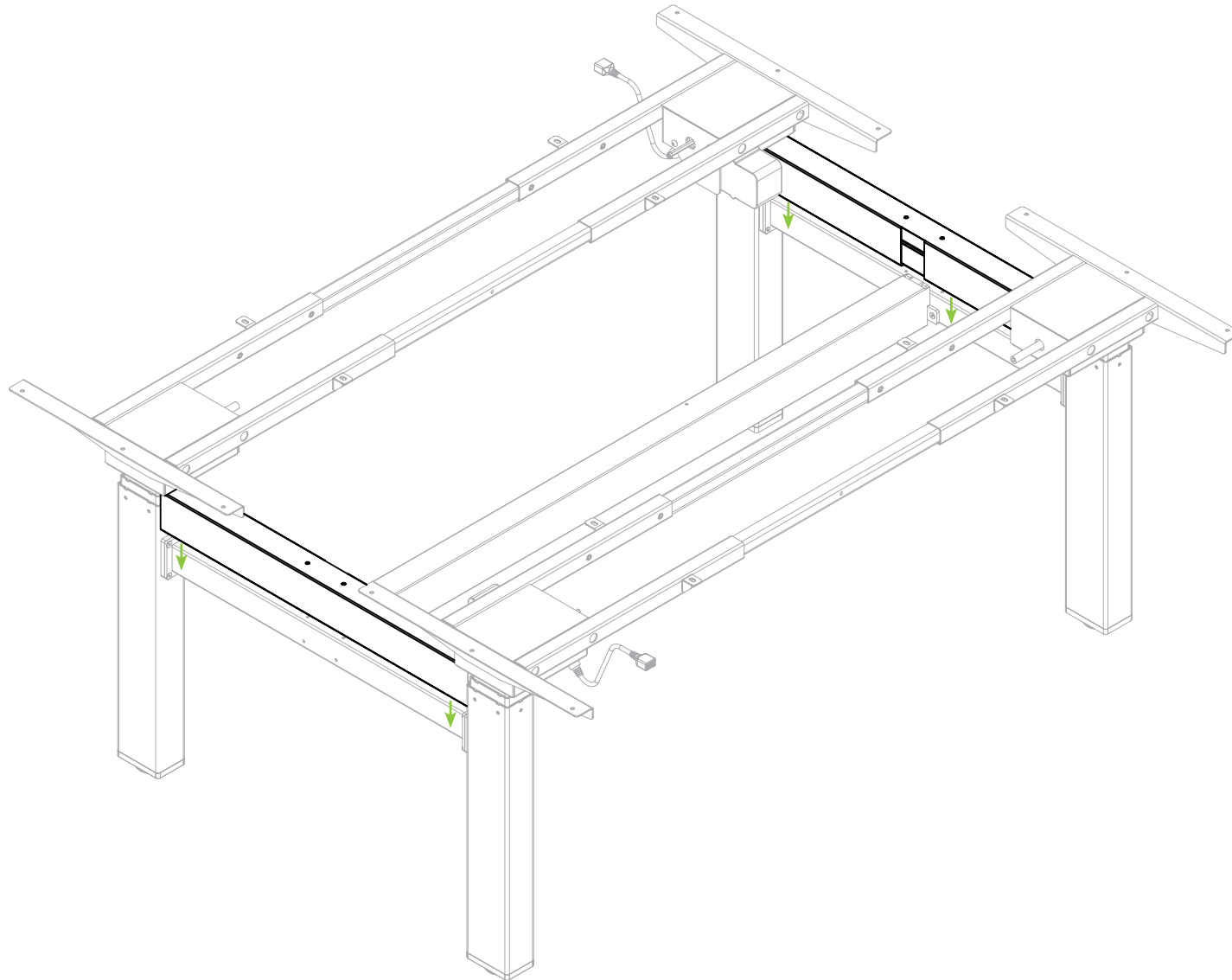

Step 9

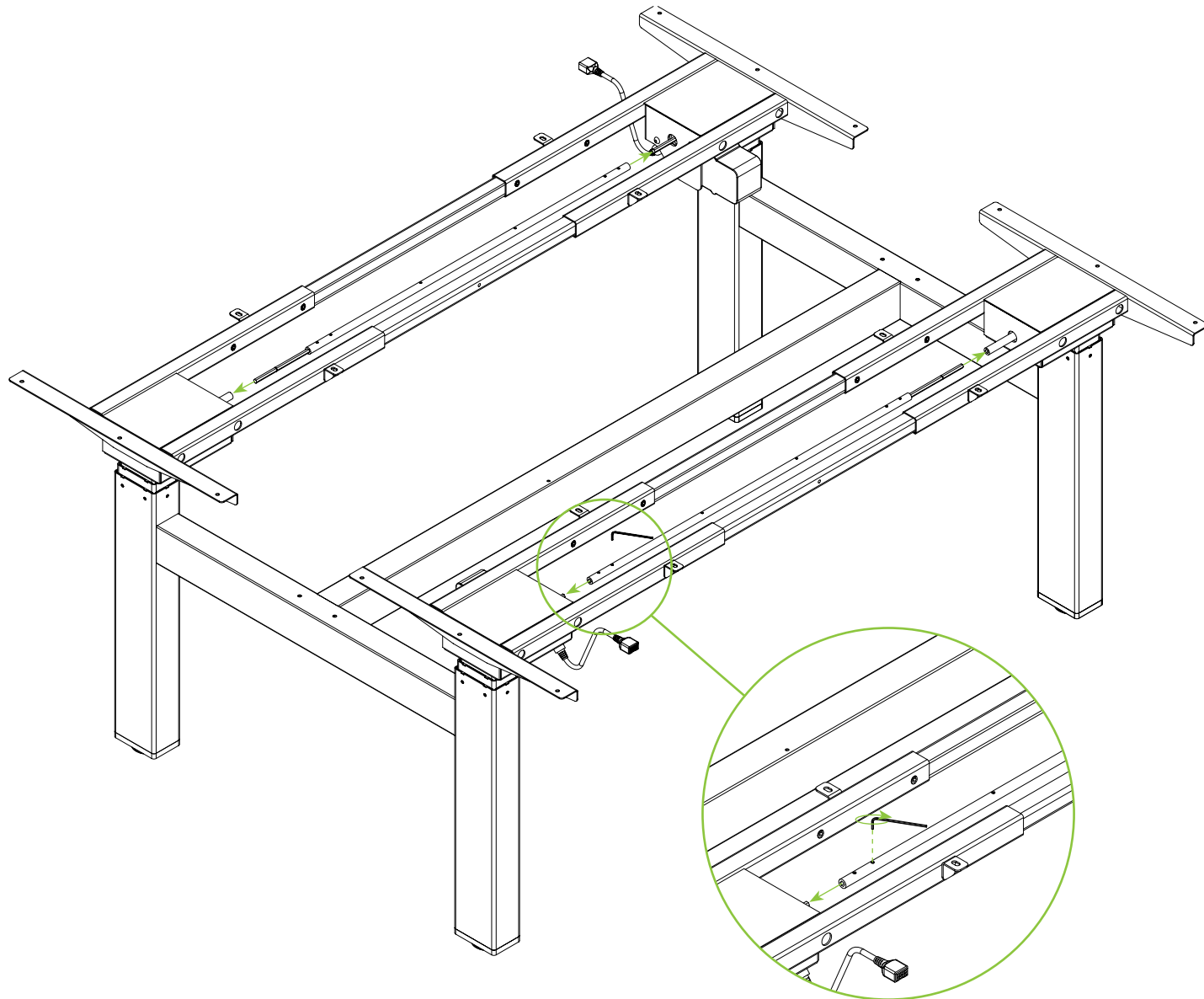

Step 10

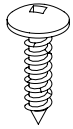

16 x ST5.0x22

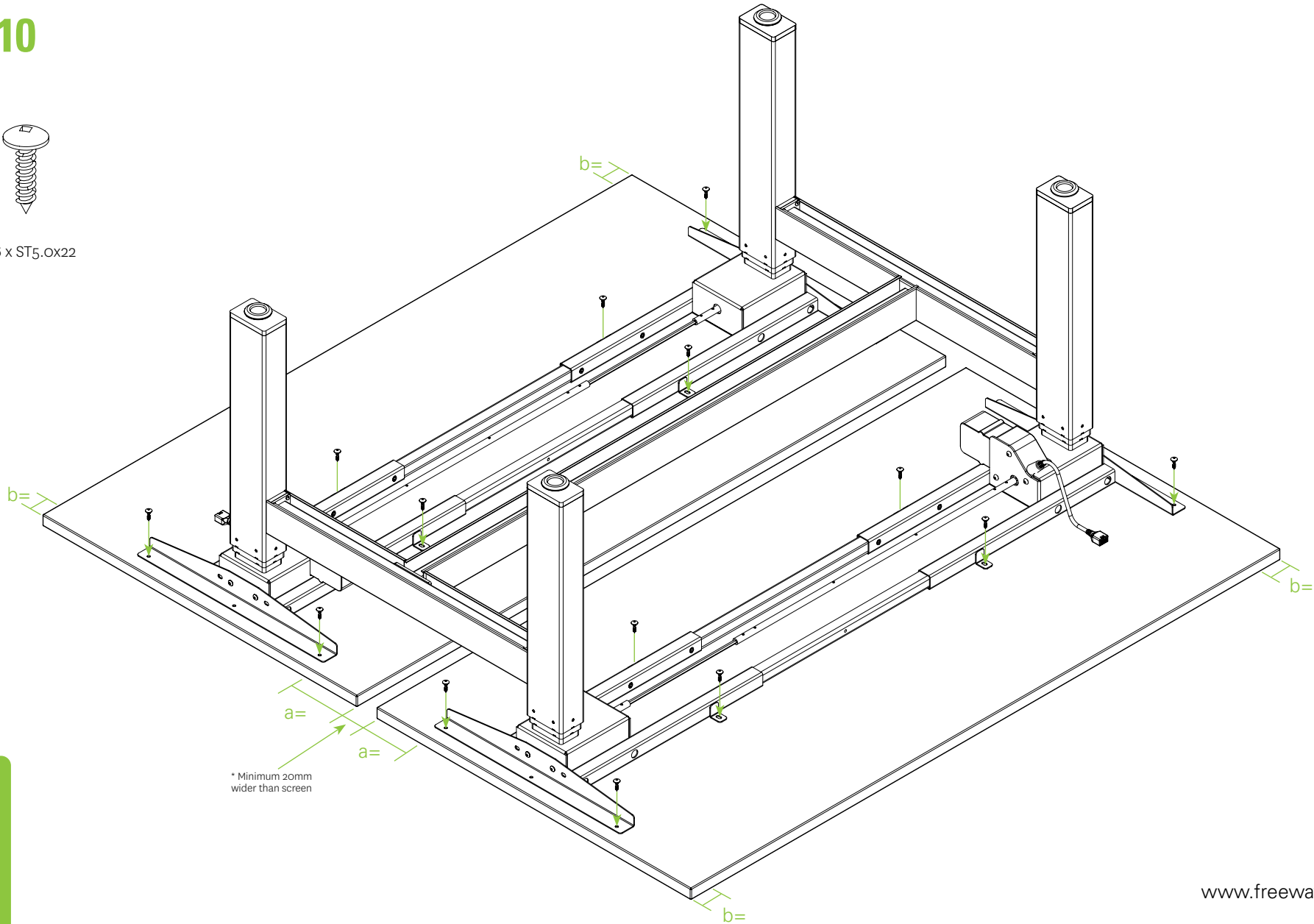

Step 11



4 x ST3-9x13

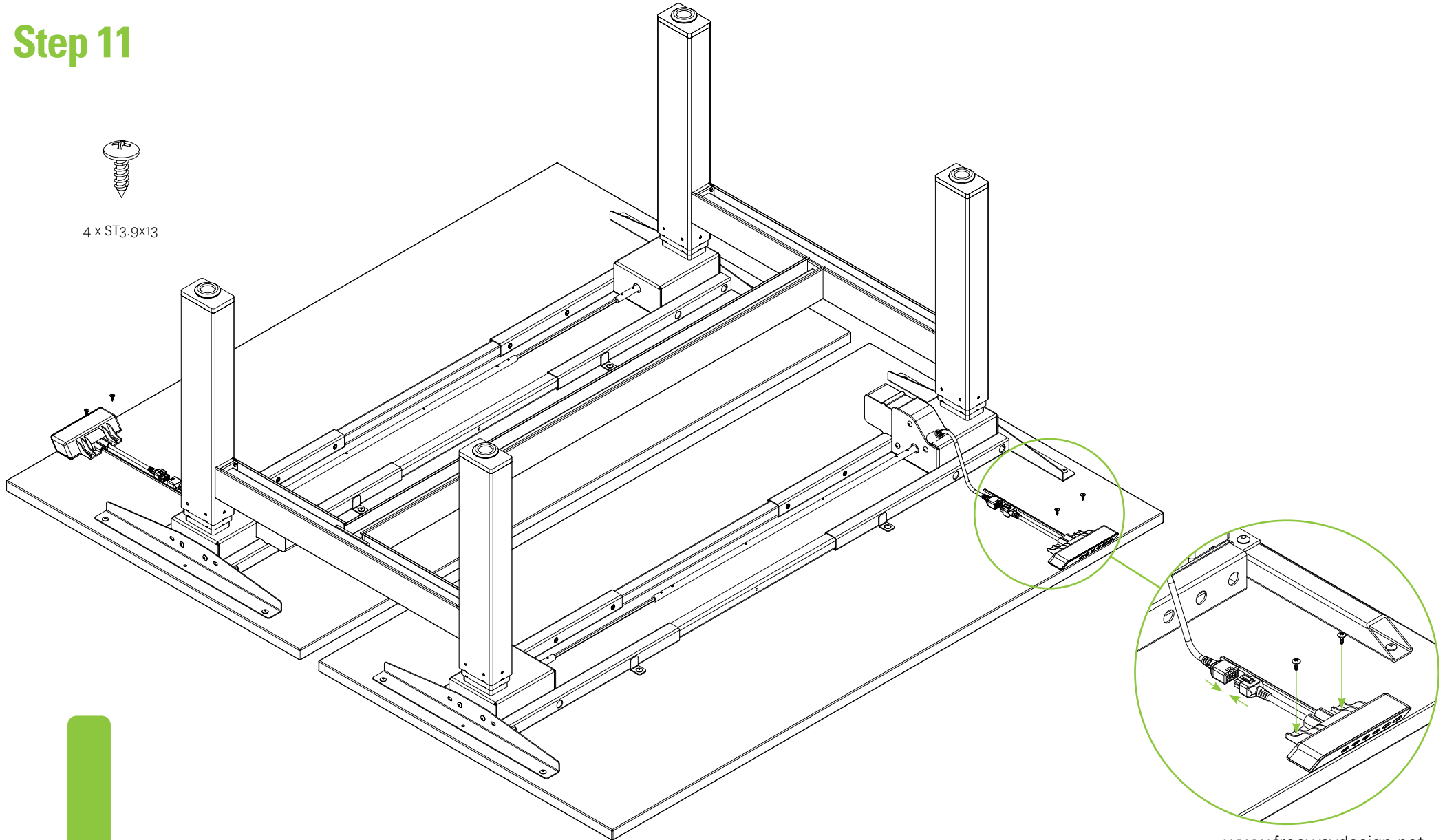

Step 12

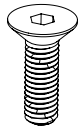

2 x M8x20

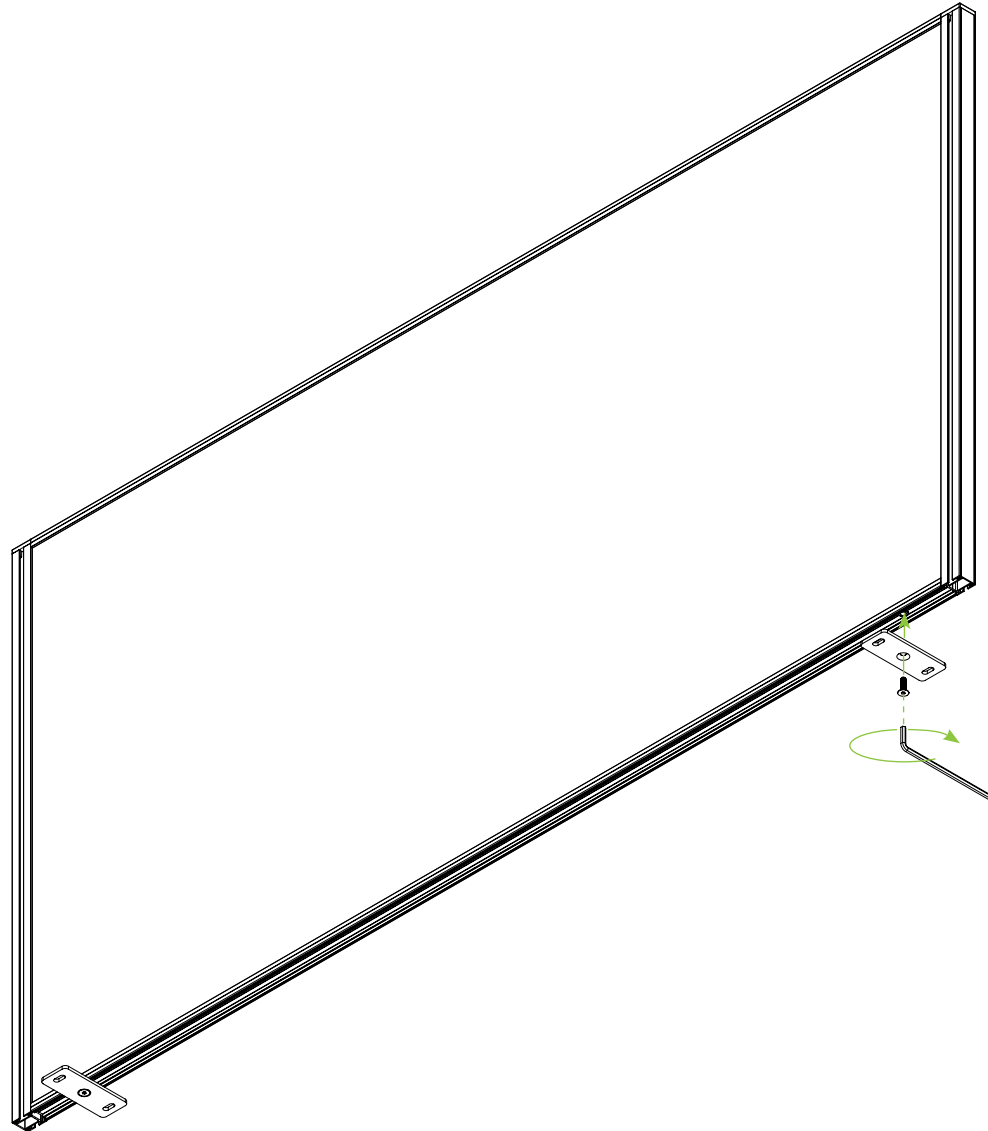

Step 13

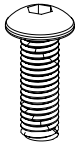

4 x M5x15

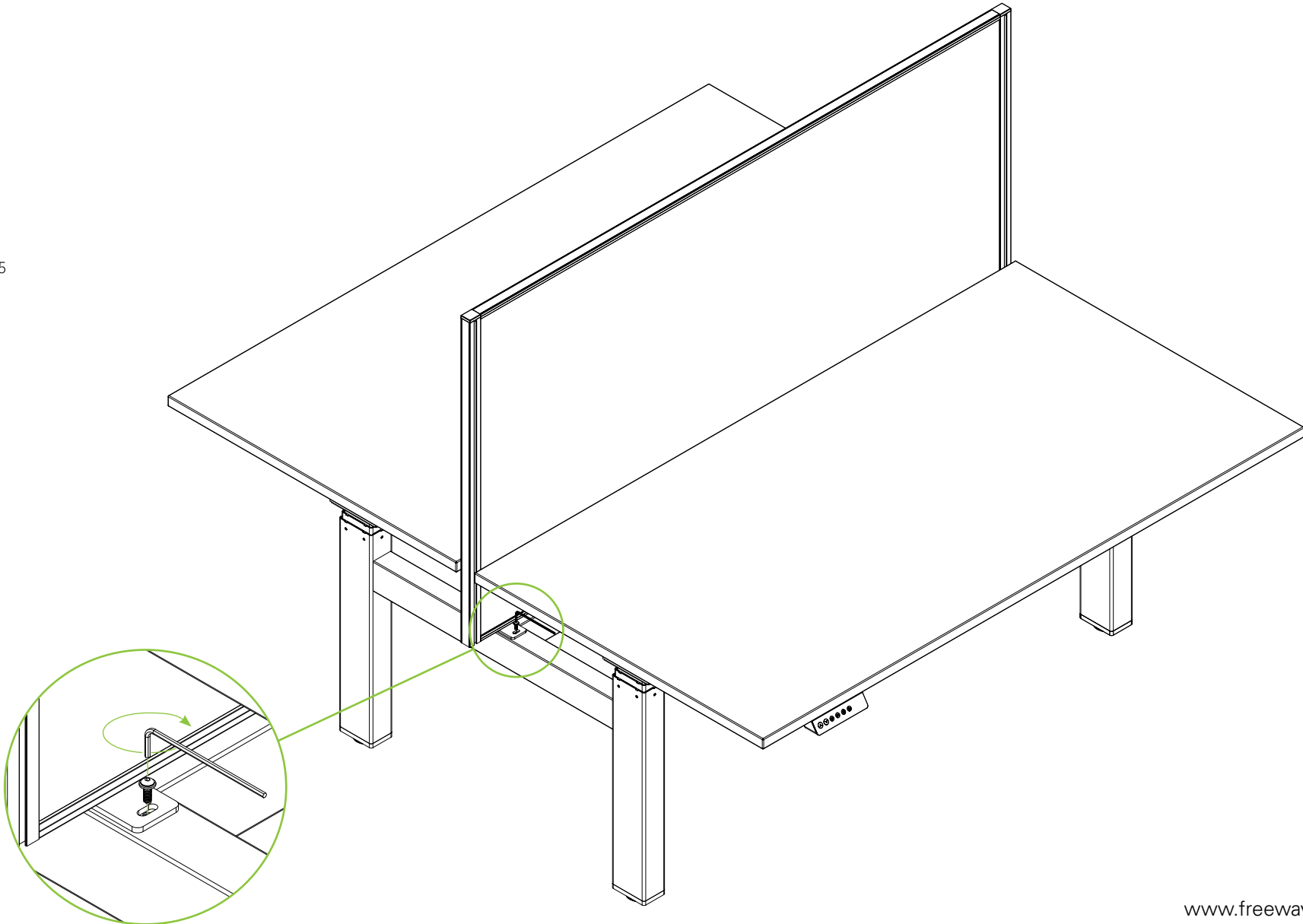

Step 14

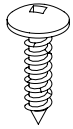

8 x ST5.0x22

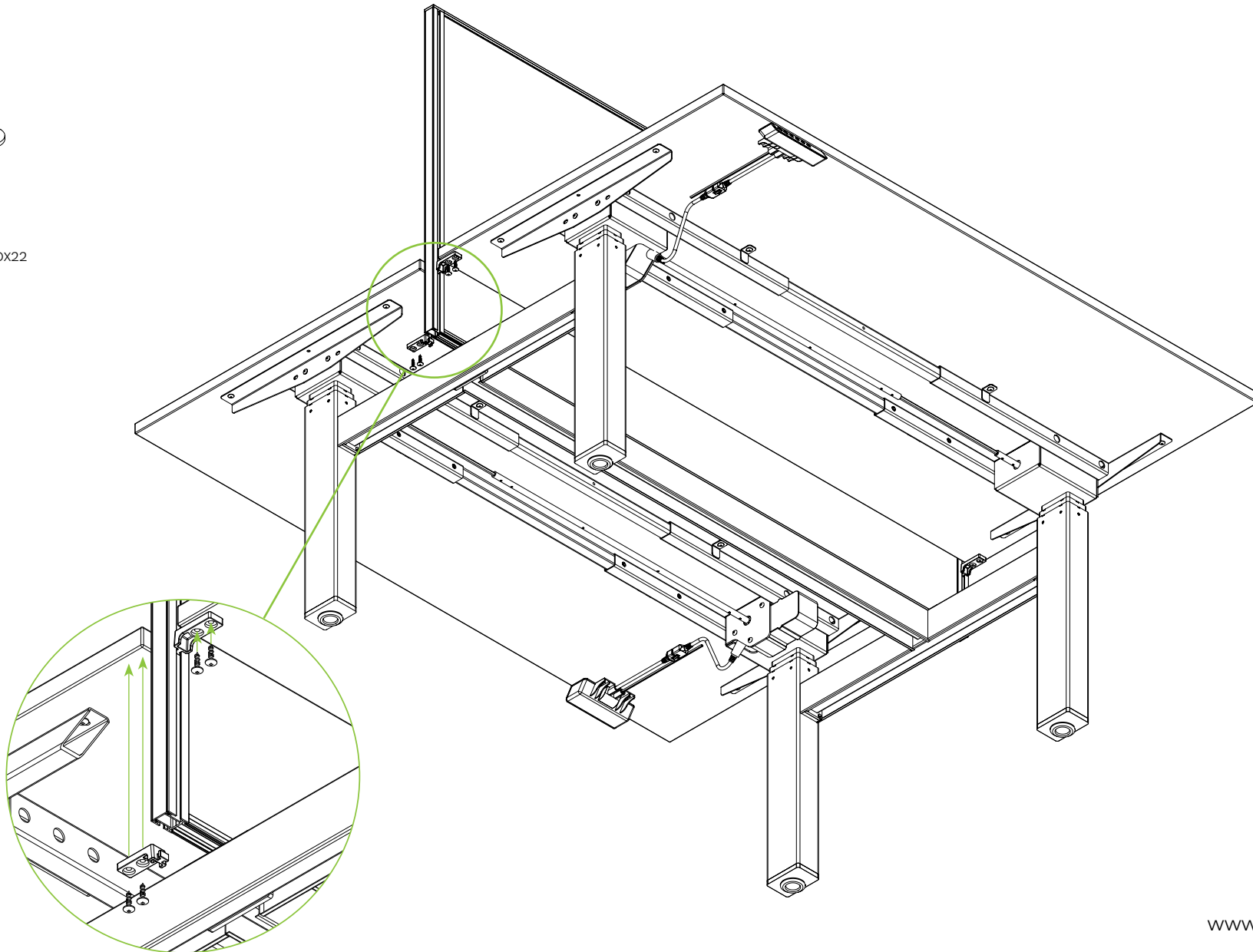

Step 15

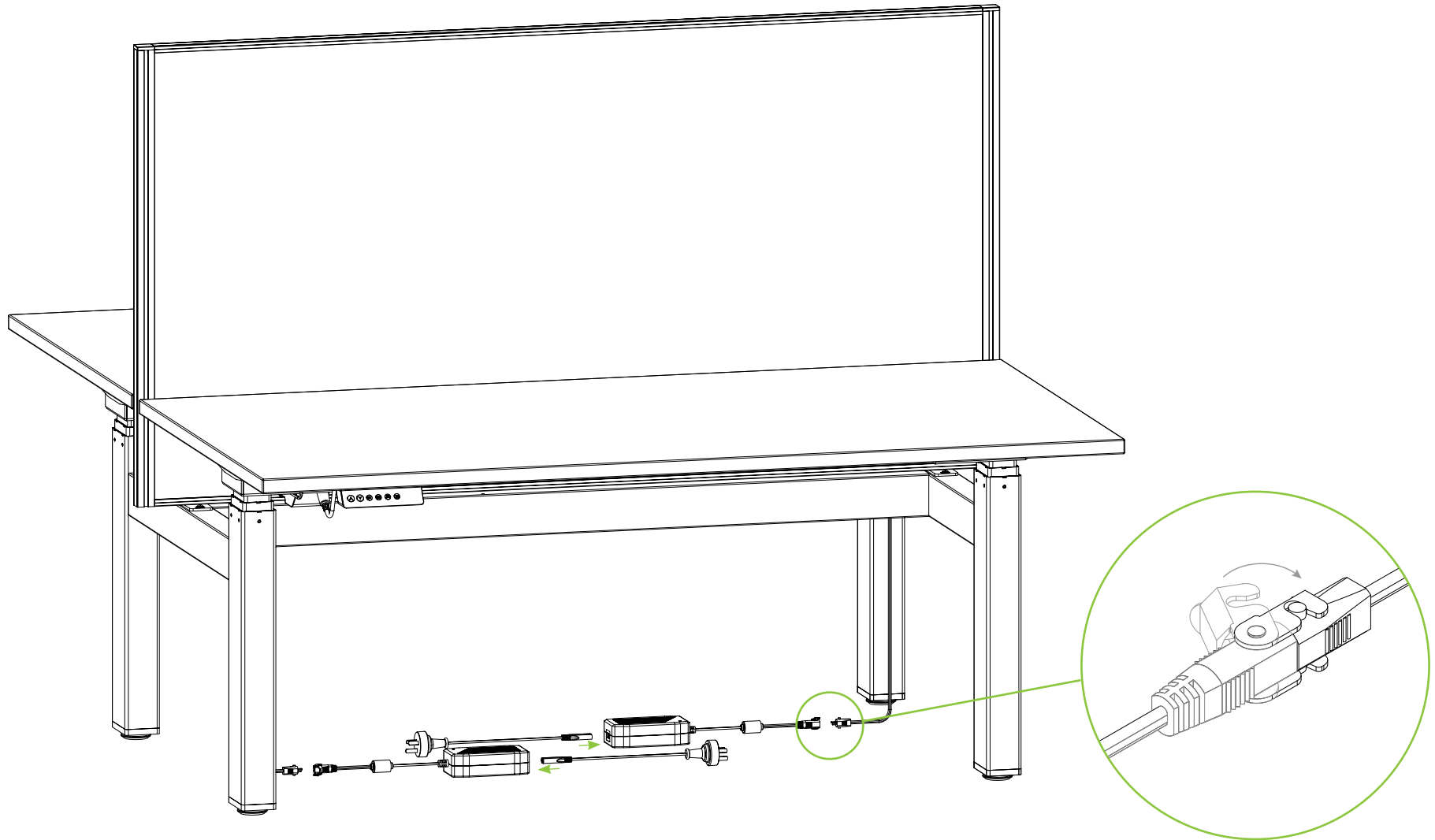

Completed

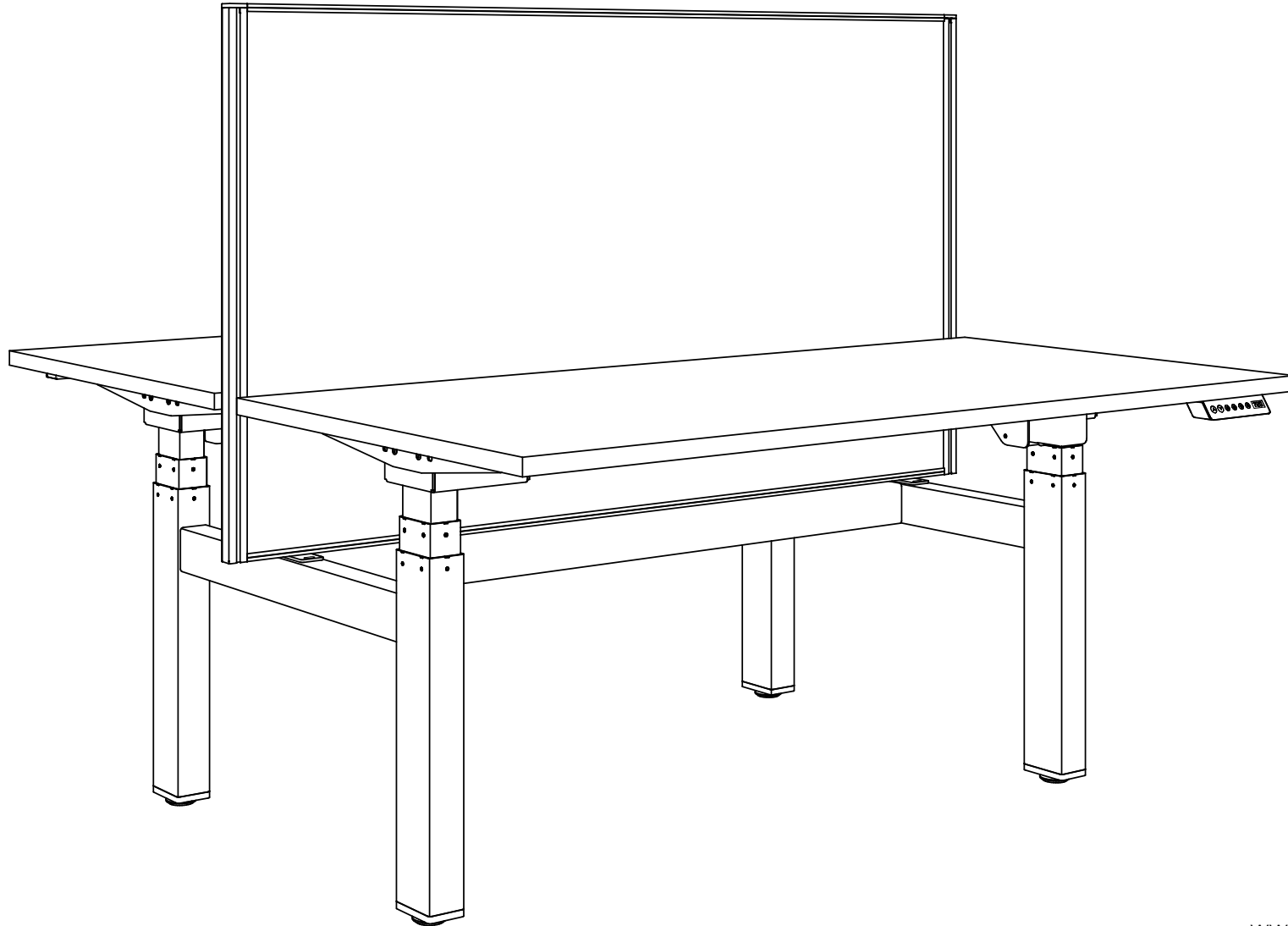

Optional Cable Tray

Installation Guide

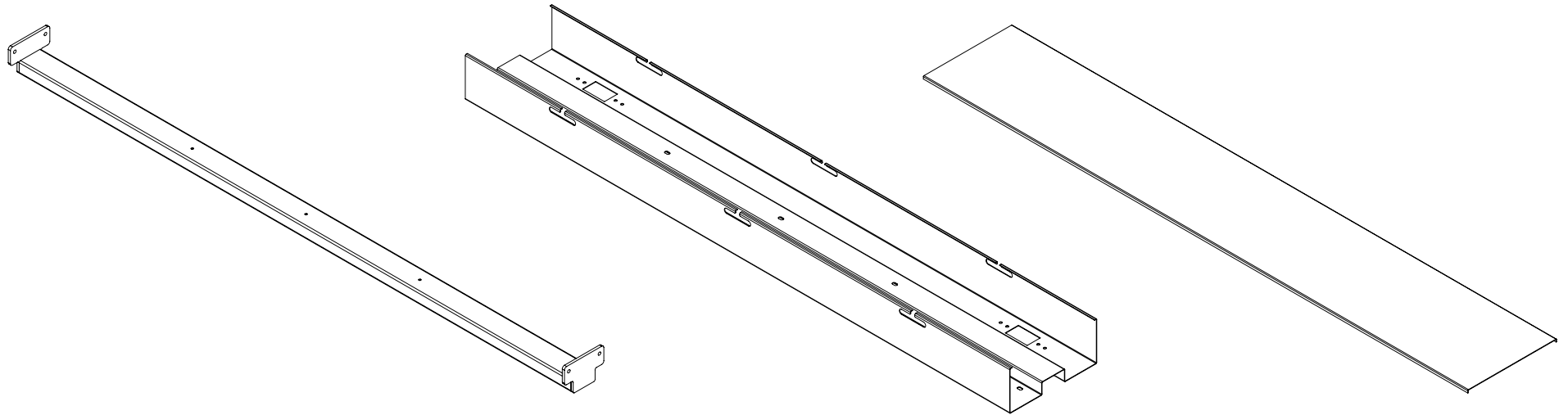

Optional Cable Tray

Installation Guide

Step 1

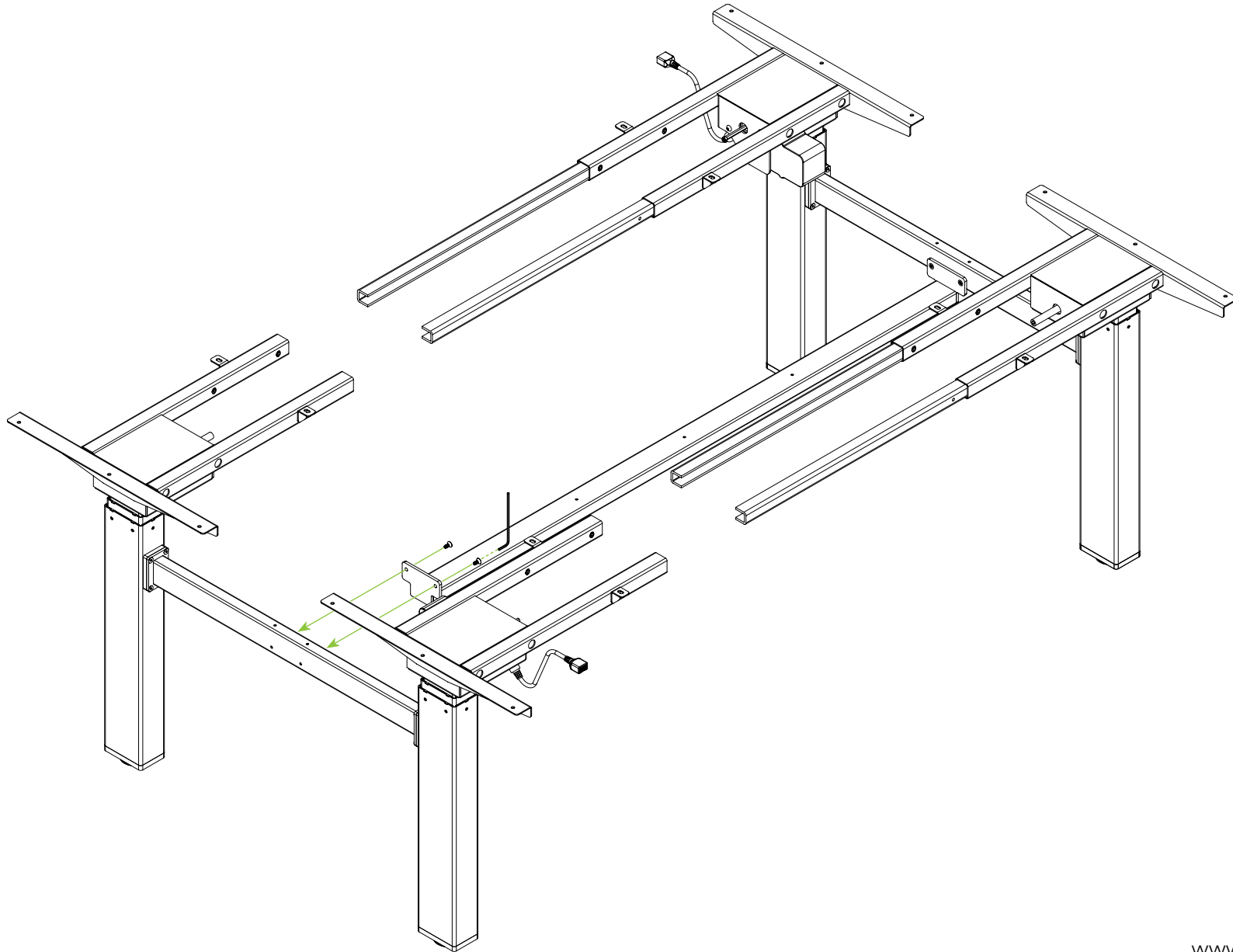

Optional Cable Tray

Installation Guide

Step 2

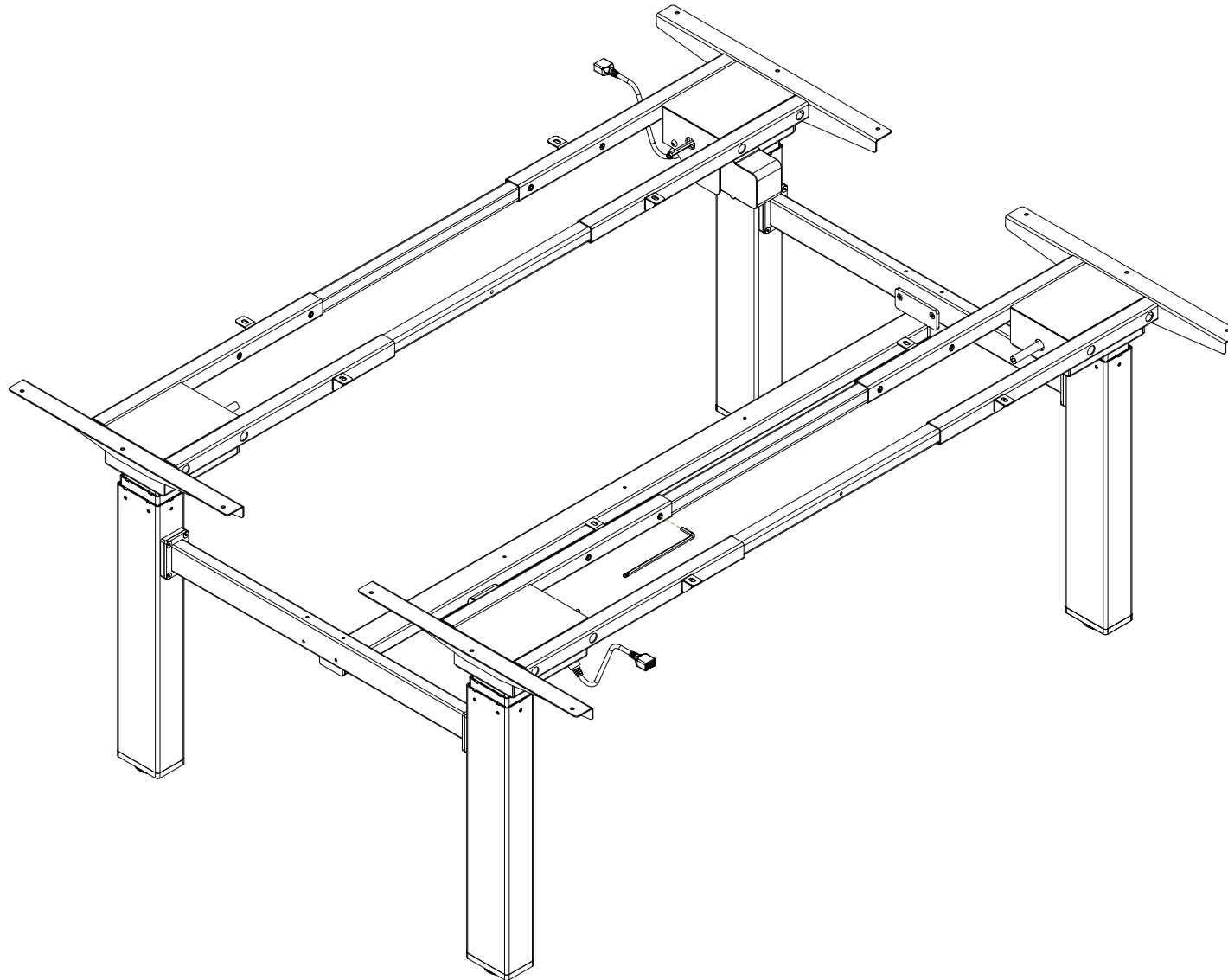

Optional Cable Tray

Installation Guide

Step 3

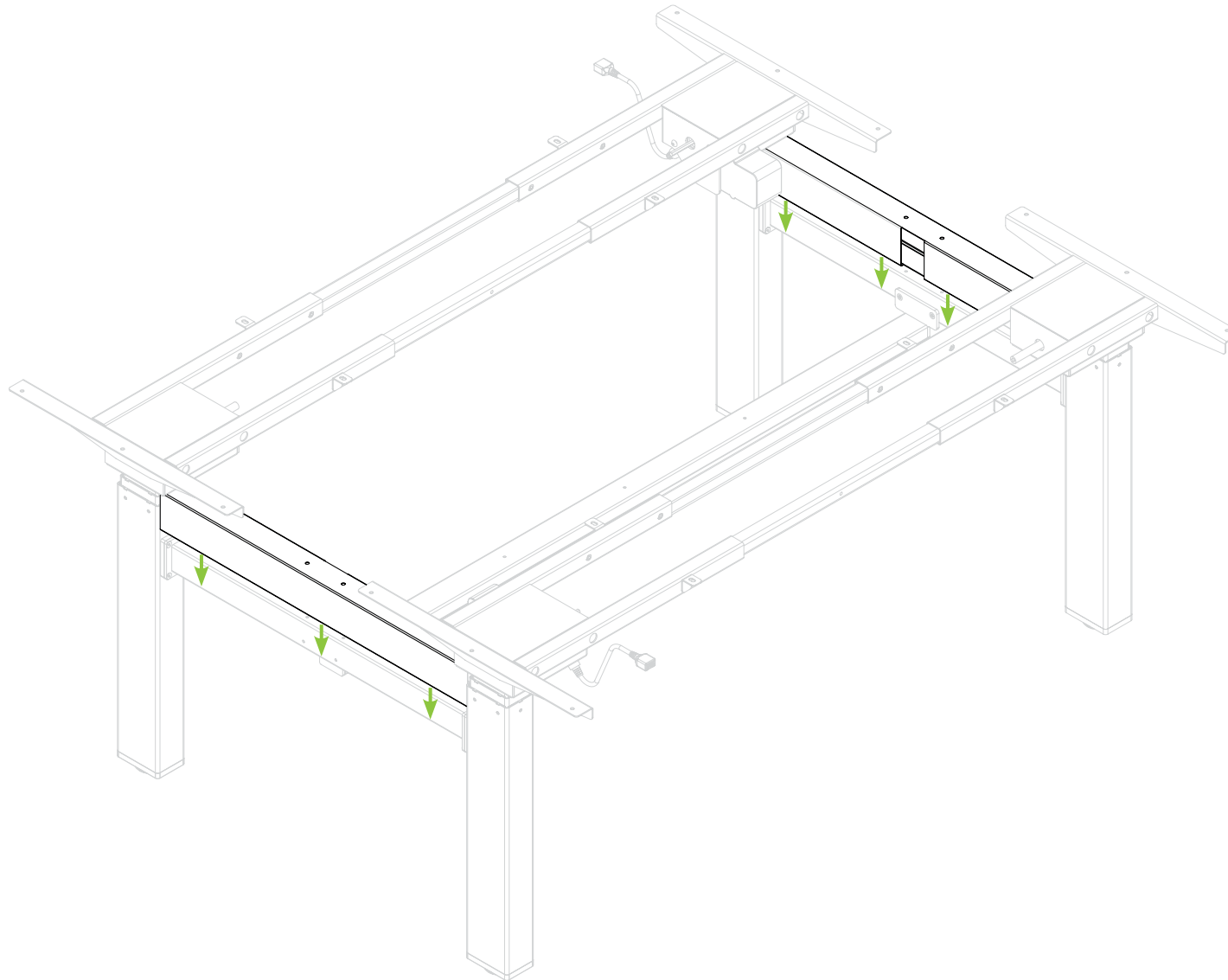

Step 4

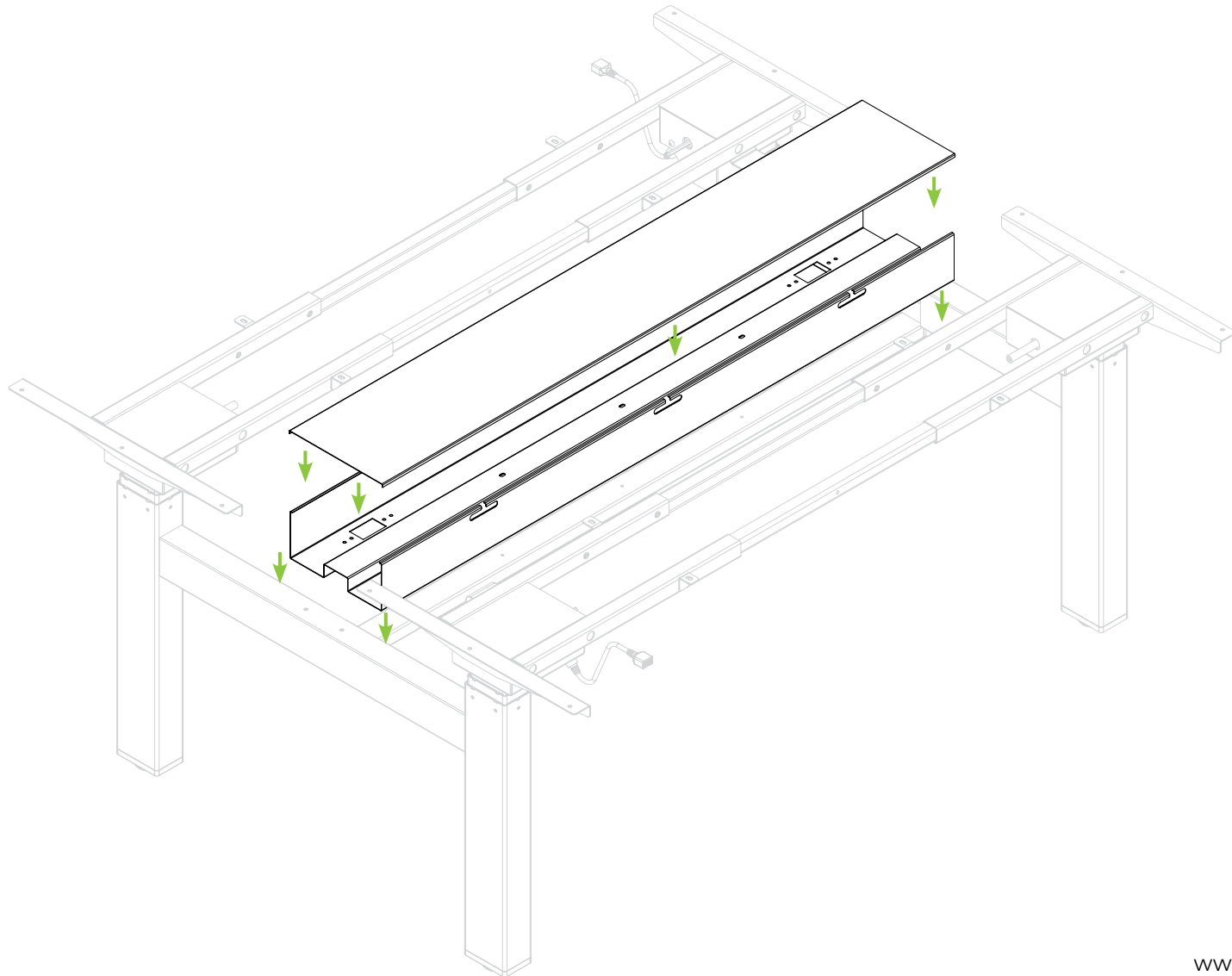

Directions For Use

IMPORTANT

Please carefully read the assembly manual and direction for use prior to instalment, use and maintenance of the table frame to gain a complete understanding of its contents. It provides you with important information about the safety, use, installation and maintenance of the table.

WARNING: FAILURE TO COMPLY WITH OR OBSERVE ALL ASSEMBLY, SAFETY AND OPERATION INSTRUCTIONS REGARDING THE USE OF THIS PRODUCT MAY RESULT IN SERIOUS BODILY INJURY.

SAFETY

- The table must be used in a safe manner. Inappropriate use may cause damage to the table and/or cause bodily harm to the user or persons nearby.
- Do not tamper with electrical components as this may lead to serious bodily harm.
- Only connect the electric table frames to the prescribed mains power voltage
- Do not use the table frame to lift people.
- Please retain this operation manual and pass it on to any future owner.

USAGE

- The height-adjustable table is designed for use in dry work environments only.
- The table height is infinitely adjustable within its height range so that it can be set to the user's most ergonomic working height. The user should seek professional help to establish their optimum working height.
- The table has been designed as a devise to elevate the users work surface and associated office peripherals. Do not use the table frame for any other purposes than that which it has been designed for. Any other use is at user's own risk!
- Do not crawl, lie or move around under the table frame, and do not sit or stand on the table frame.
- CHILDREN should only use the table when supervised by adults.
- Liability: The manufacturer accepts under no circumstances warranty claims or liability claims for damages arising from improper use or handling of the table frame other than that described in this operation manual.

SET UP AND INSTALLATION

Assemble the table frame according to the assembly instructions on pages 4 - 12.

- Place the table in a safe distance from window frames, radiators, furniture etc. so that persons cannot become trapped.
- Level the table with the adjustable feet ensuring that the table is stable.
- Check that no cables can get jammed.
- Connect the table to the 110 or 230 VAC power outlet.

The table is now ready for use.

Directions For Use

MAINTENANCE AND DEFECTS

- The table does not require any maintenance by usage as described in chapter 2 in the directions for use.
- The table is only to be maintained with a wrung cloth.
- In the event of the occurrence of jarring sounds during operation, STOP using the table and please contact the dealer.

TECHNICAL DATA

Height Range: 610-1230mm including worktop

Speed: ~30mm/s

Input Voltage: 100-240V AC 50-60Hz

Output Voltage: 24V DC 2.0A

Duty Cycle: 10% 2min on 18min off

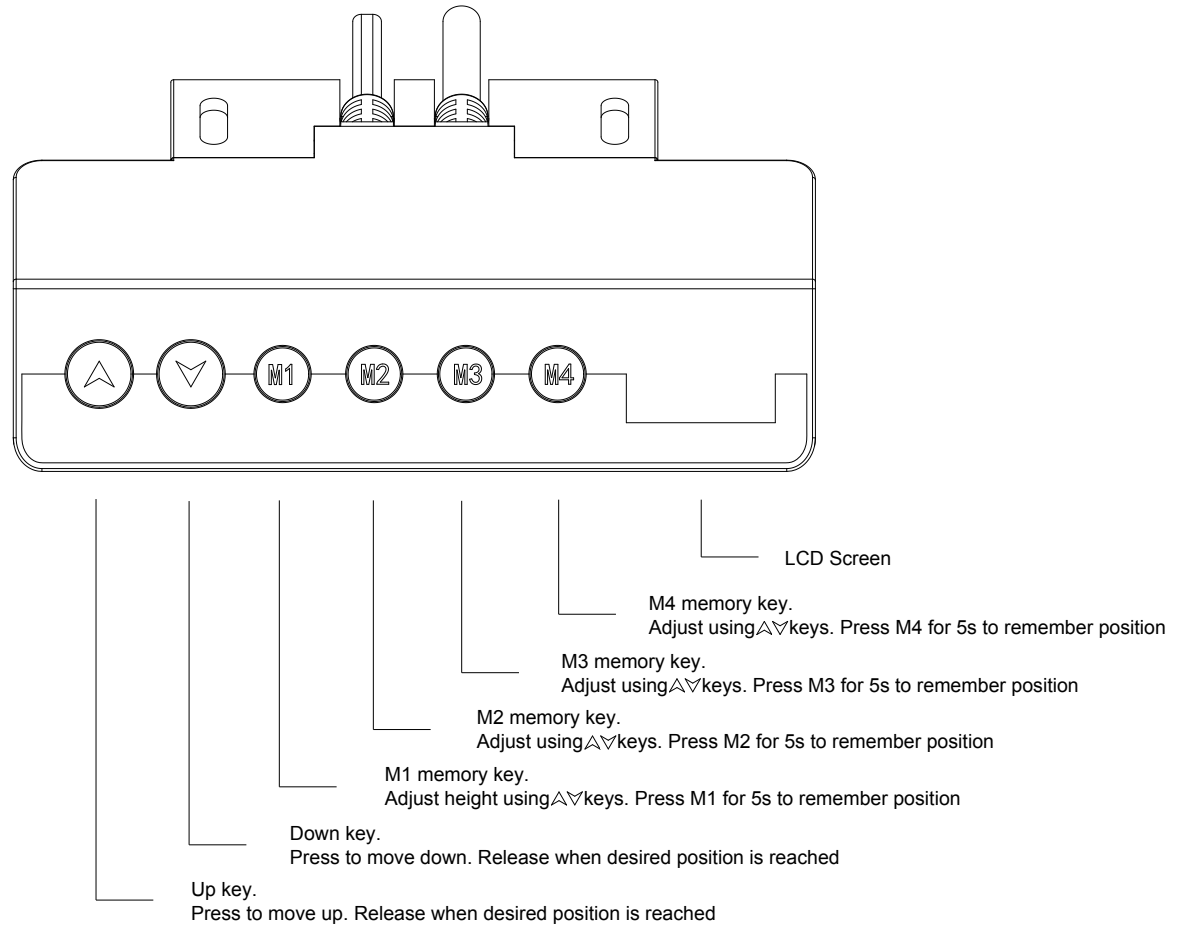



freeway

Agile

Installation Guide - Electric 2 Column

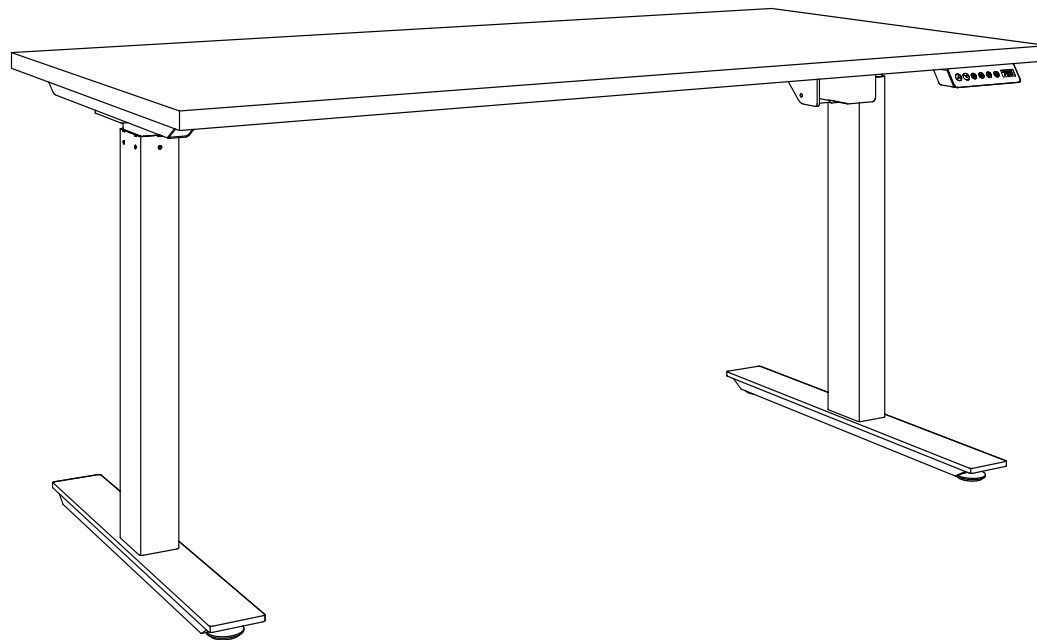

Parts:

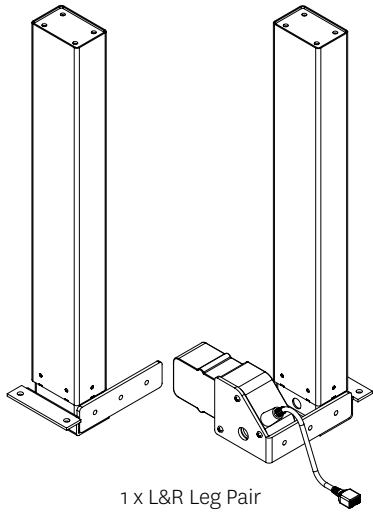

1 x L&R Leg Pair

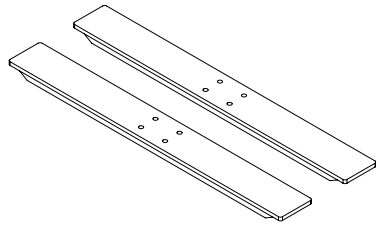

2 x Foot

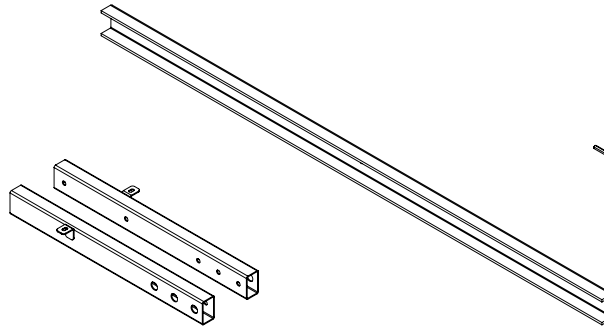

2 x Leg Rail Pair

1 x Cross Rail

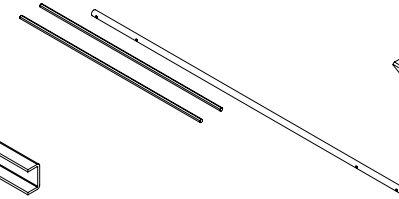

1 x Drive Shaft

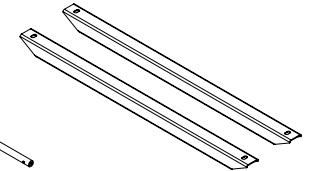

1 x L&R Support Bar Pair

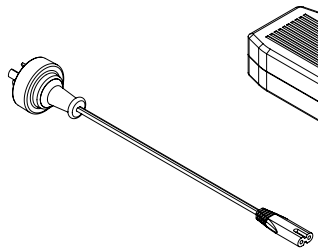

1 x Power Cord

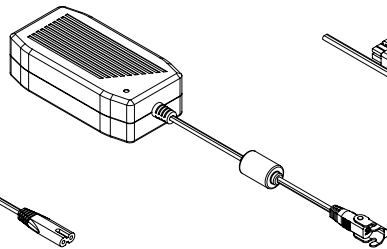

1 x Power Supply

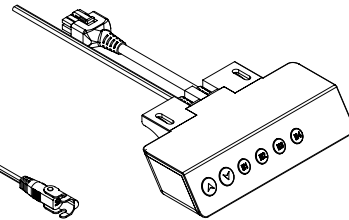

1 x Handset

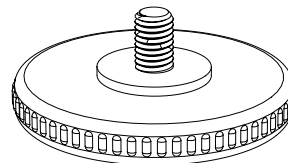

4 x Levelling Foot

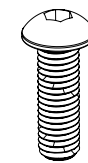

8 x M8x25



8 x M8x10



6 x ST5.0x23



2 x ST3.9x2

Step 1



4 x M8x10

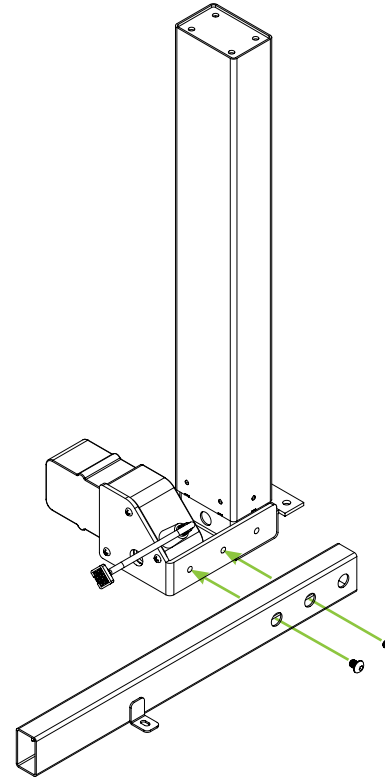
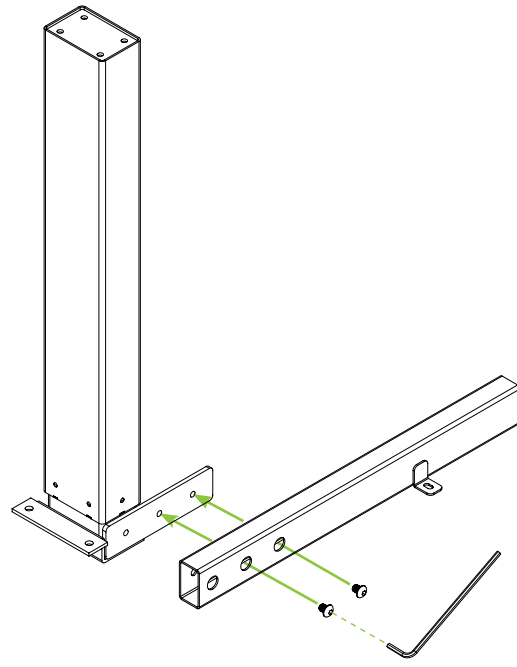

Step 2



4 x M8x10

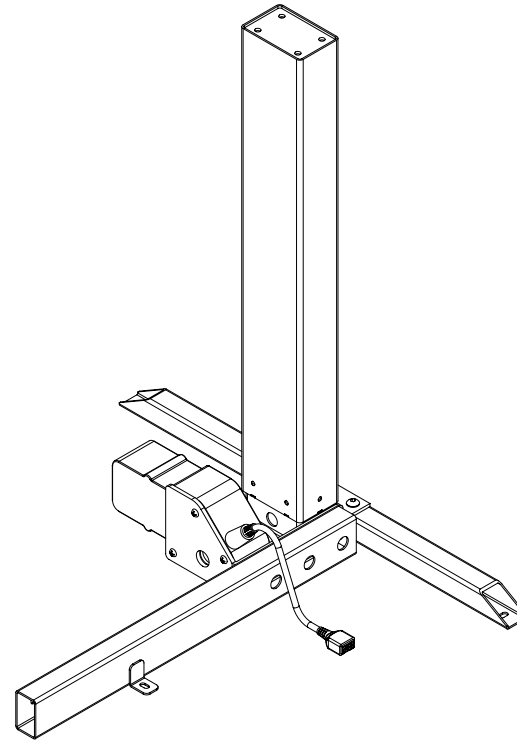
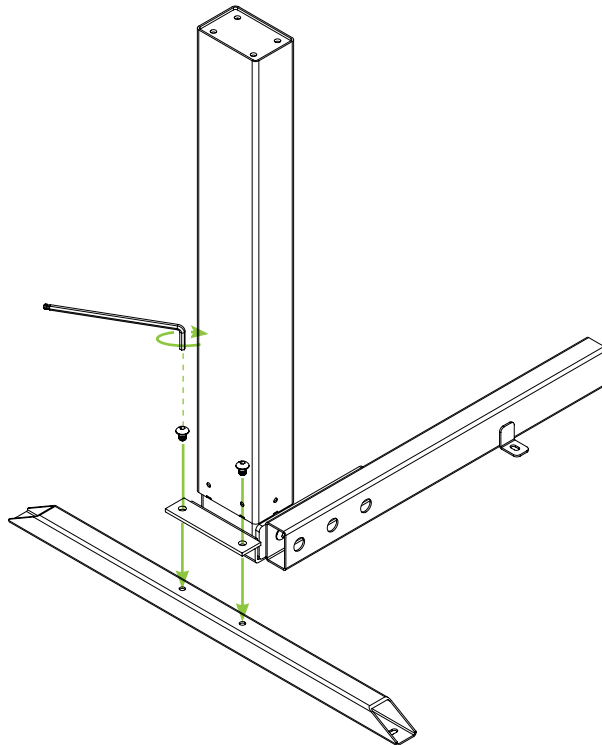

Step 3

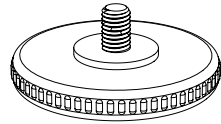

4 x Levelling Foot

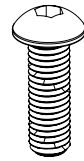
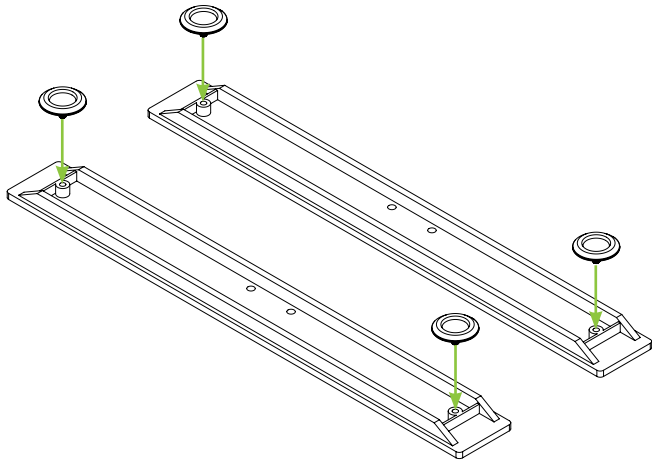

8 x M8x25

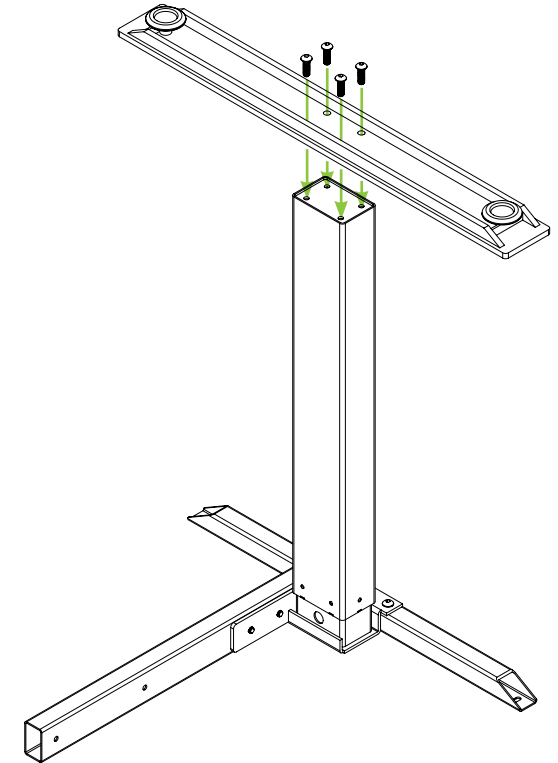
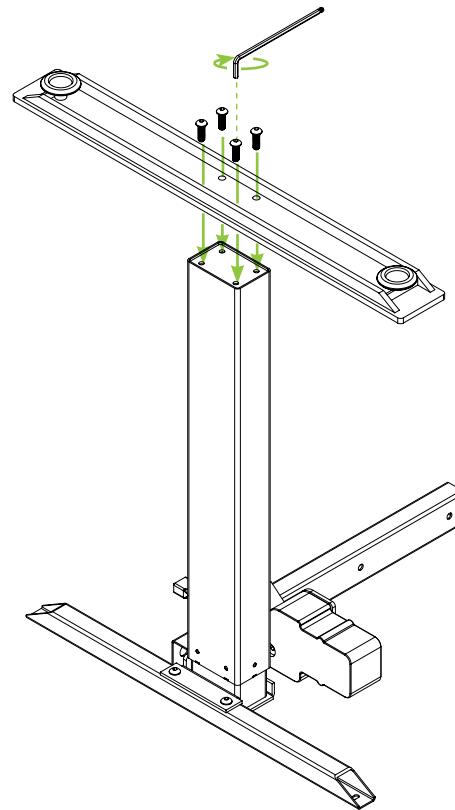

Step 4

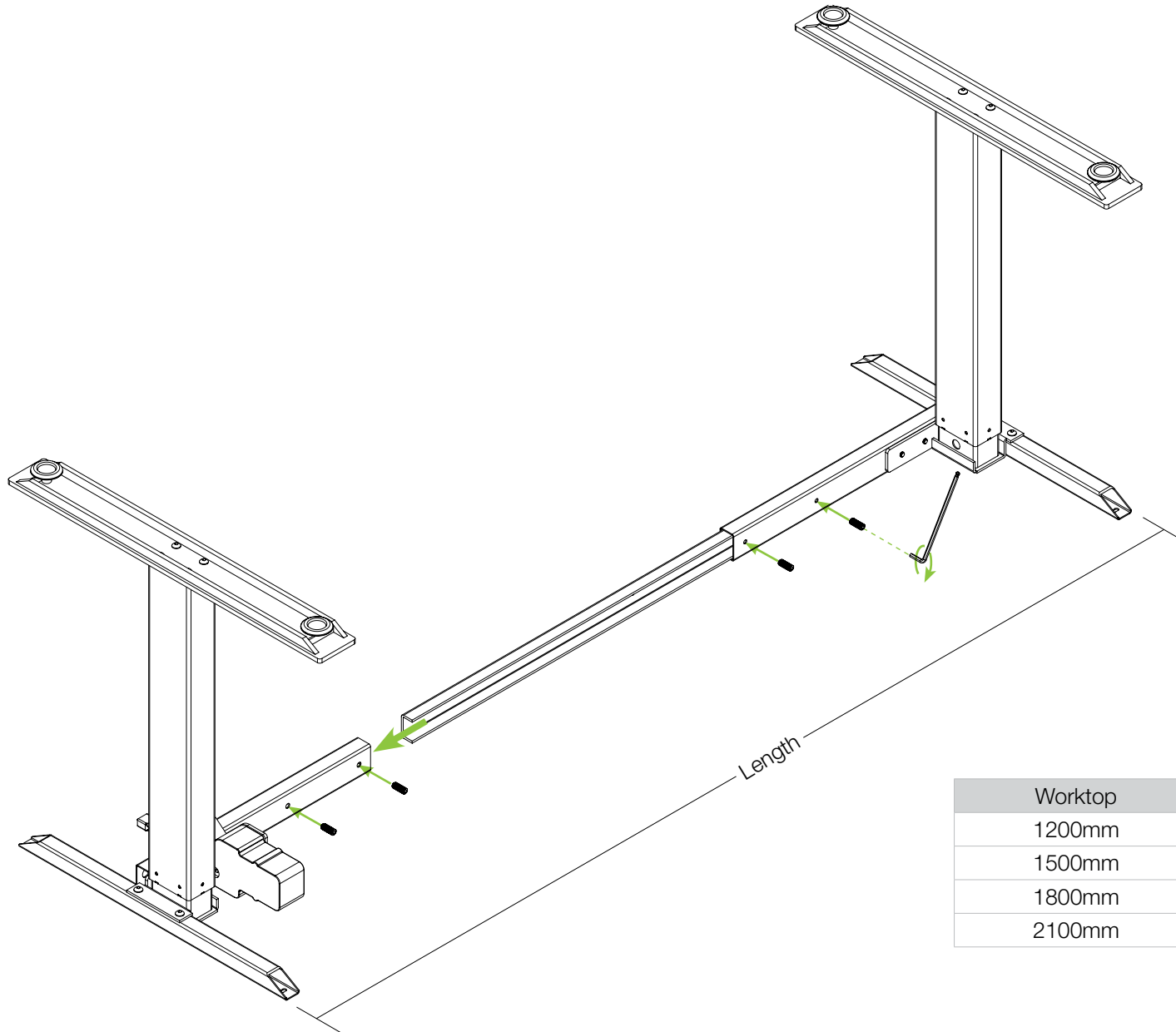

Worktop	Length
1200mm	1125mm
1500mm	1425mm
1800mm	1725mm
2100mm	2025mm

Step 5

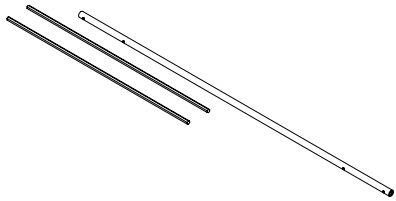

1 x Drive Shaft

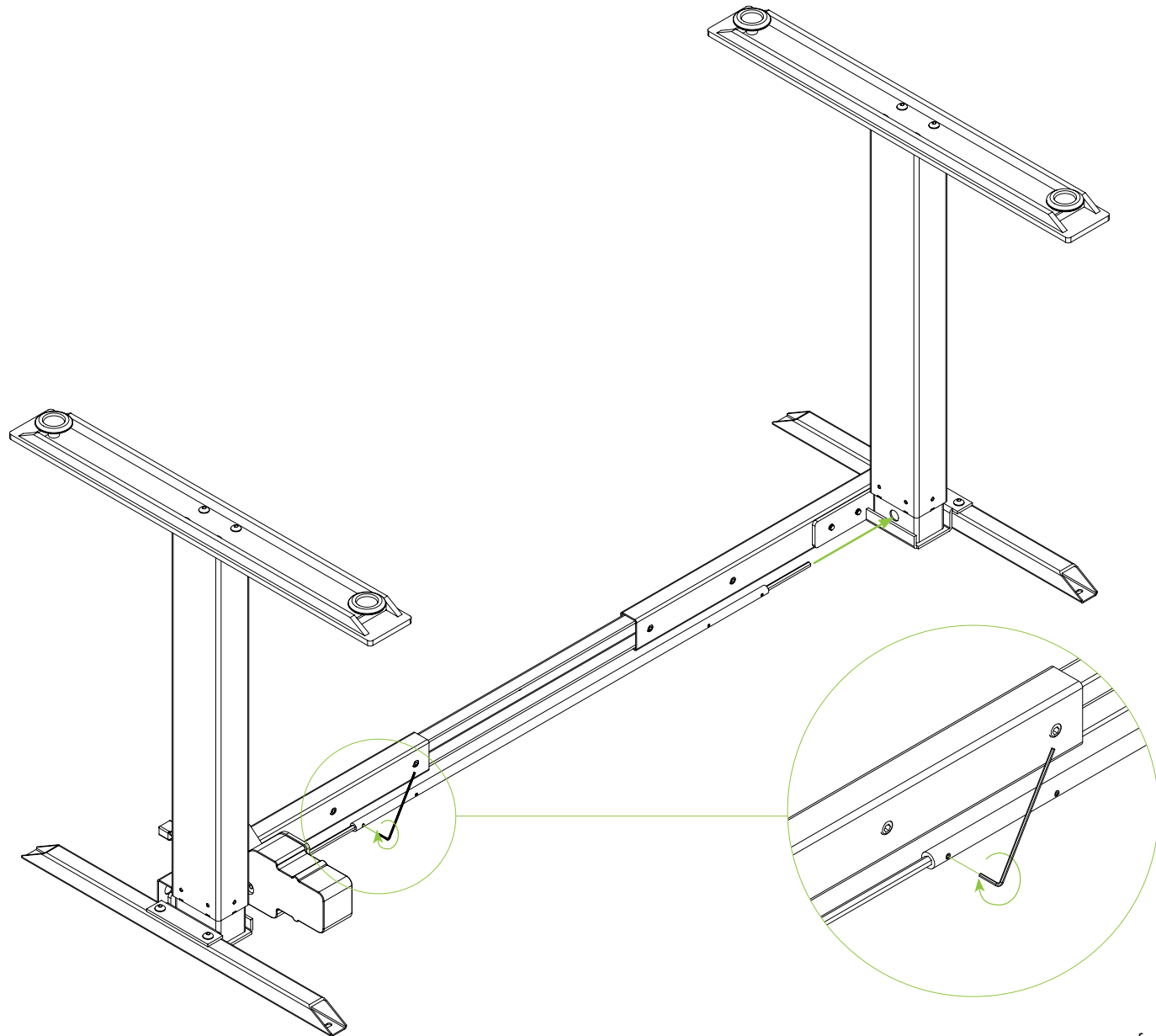

Step 6

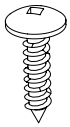

6 x ST5.0x23

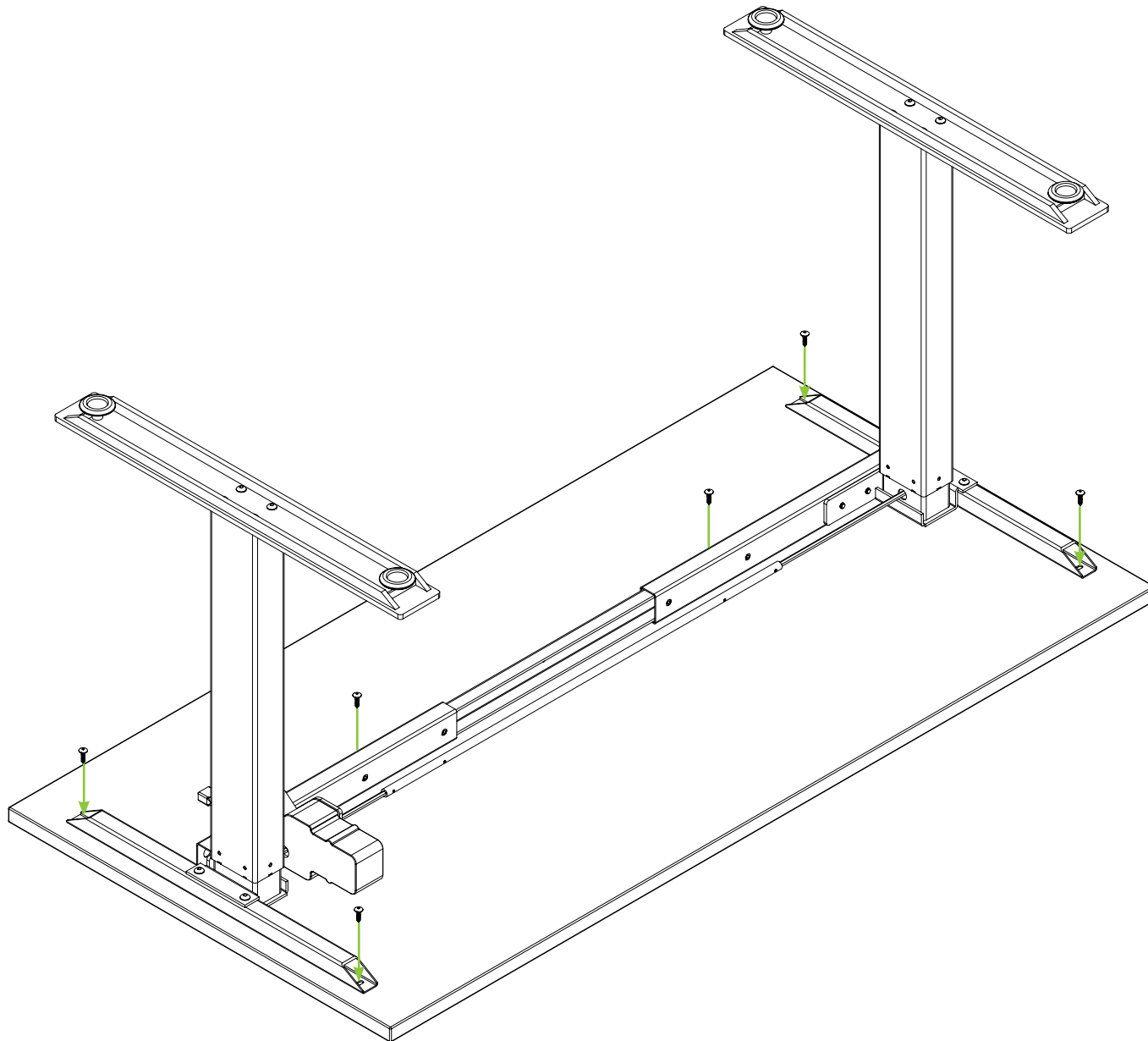

Step 7



2 x ST3.9x13

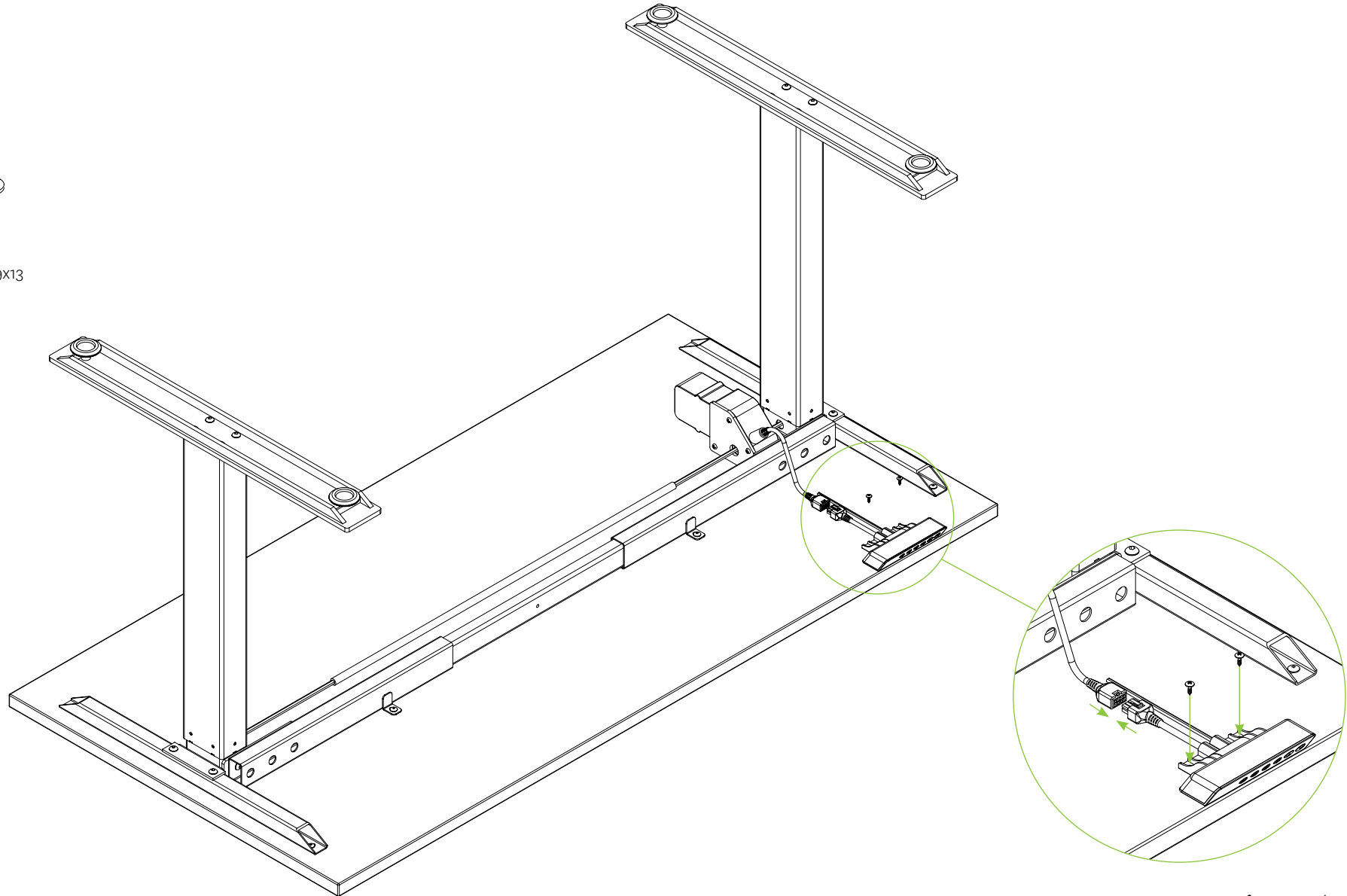

Step 8

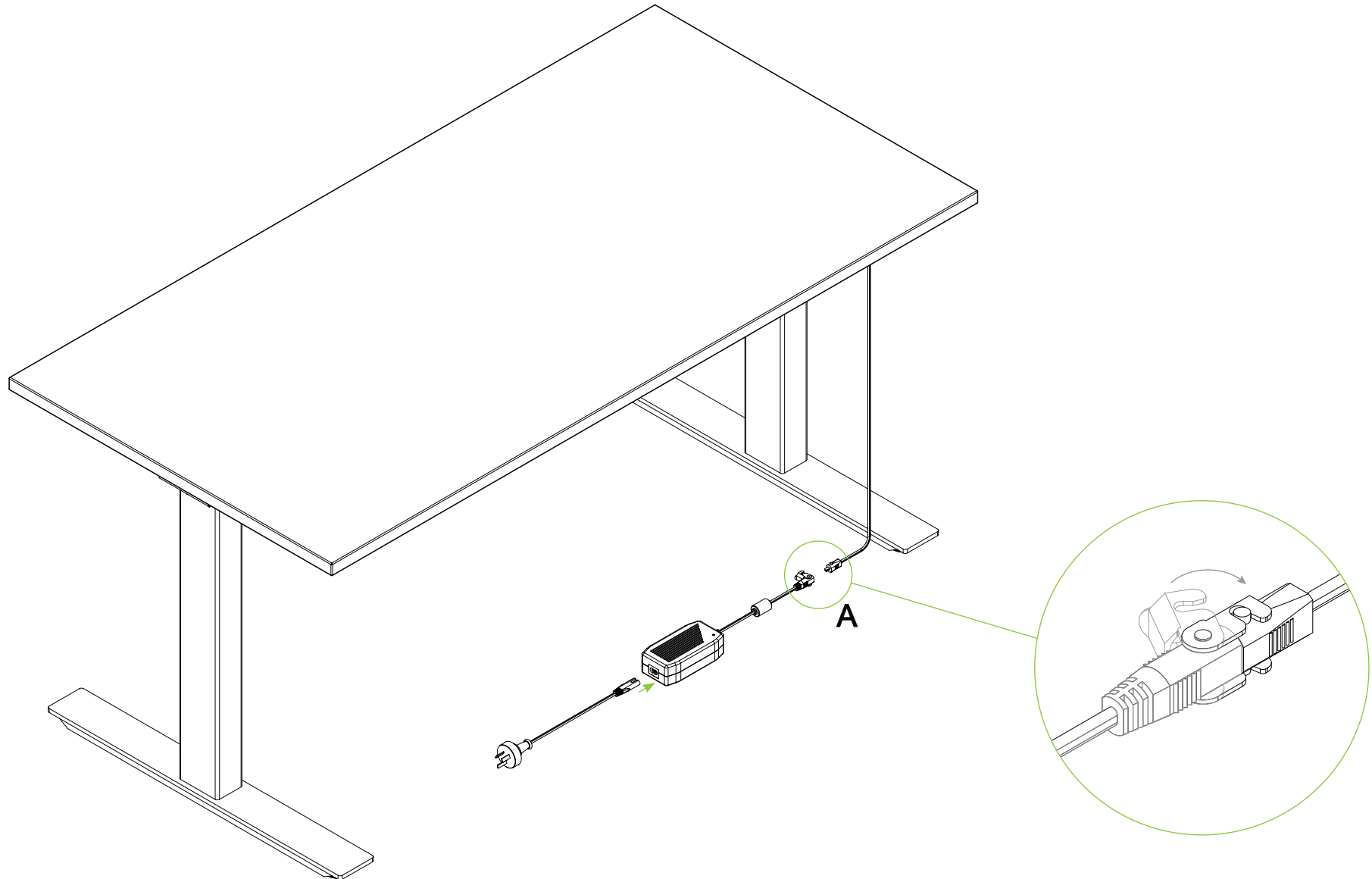

Completed

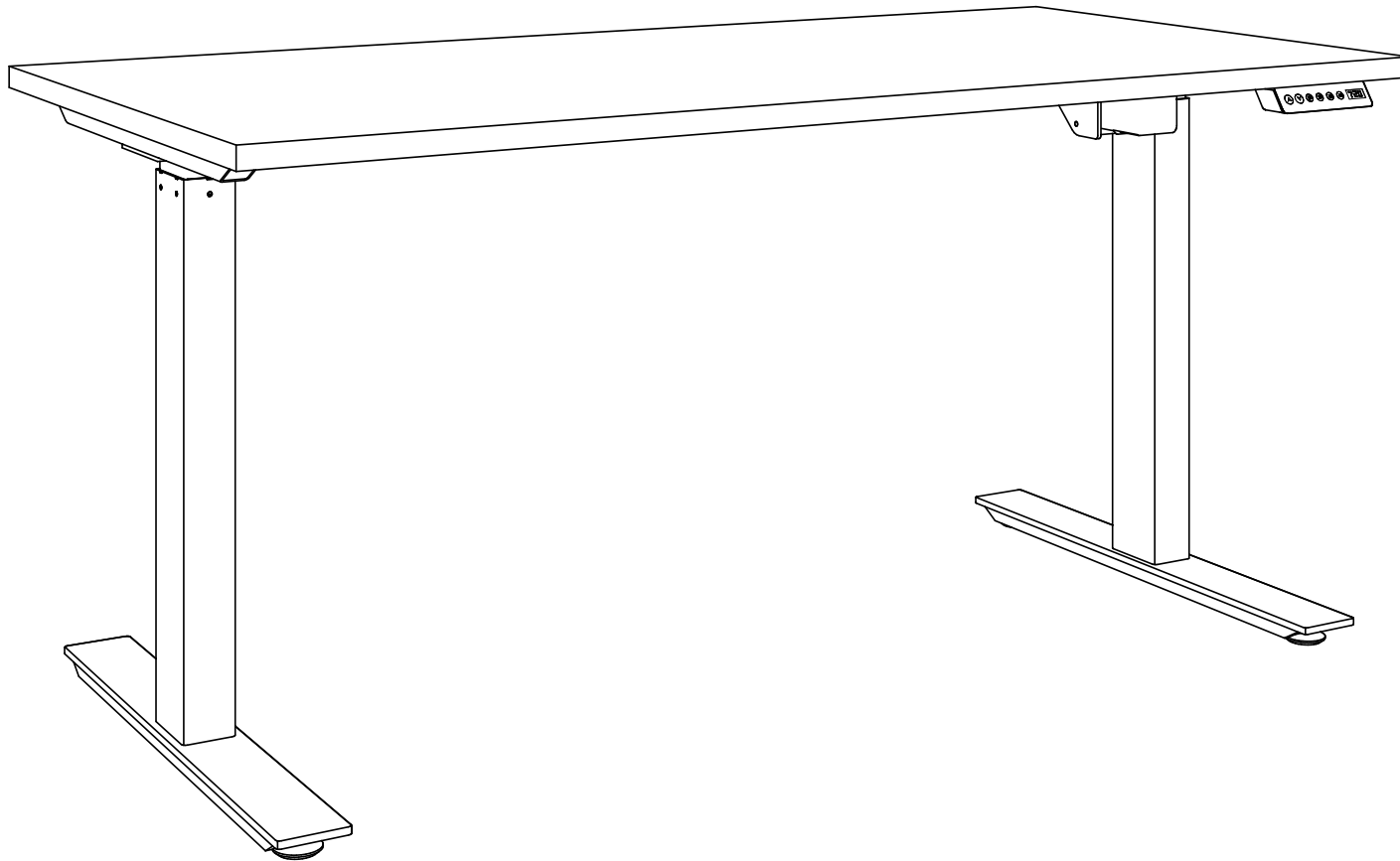

Optional Desk Hung Screen

Installation Guide

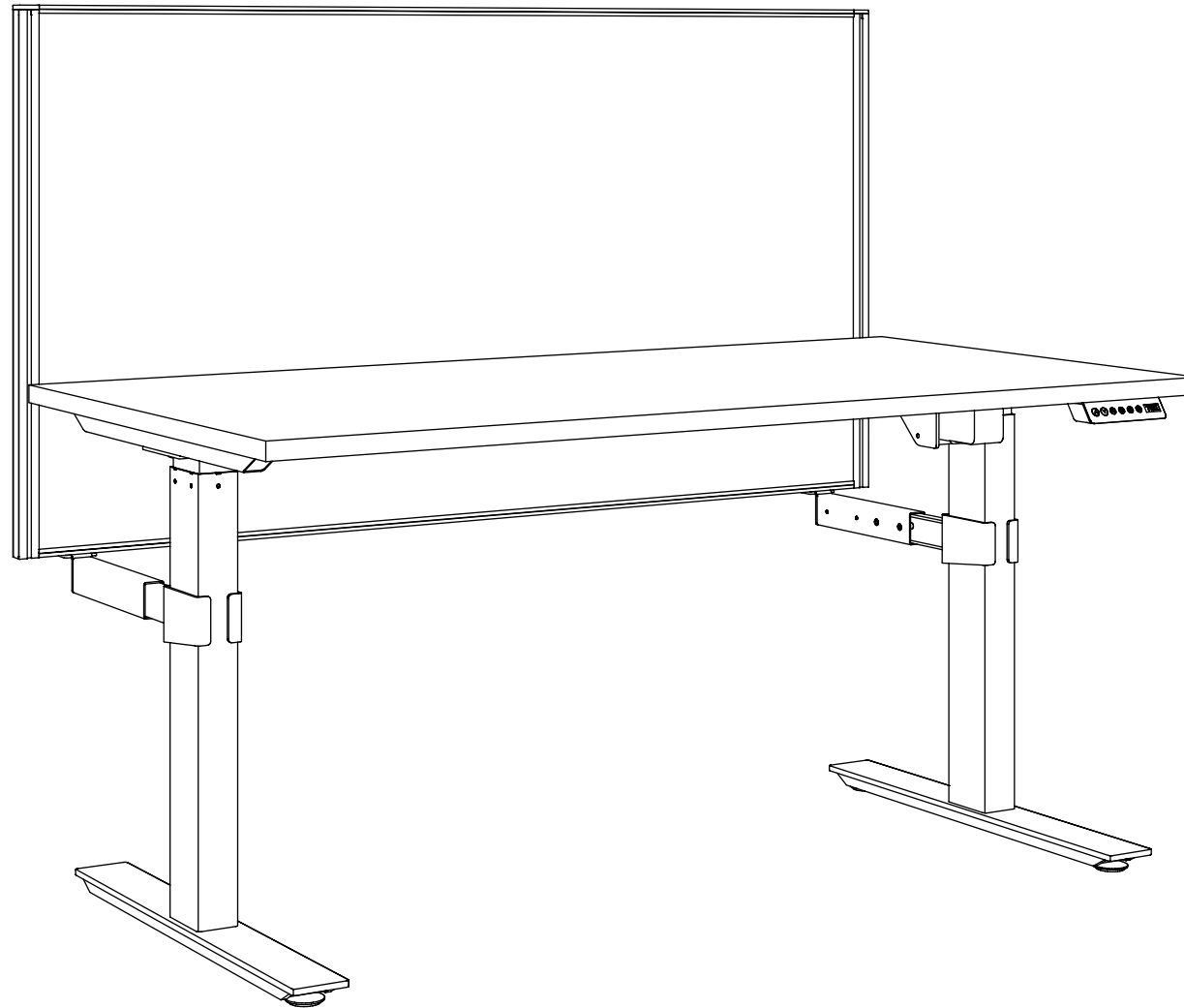

Optional Desk Hung Screen

Installation Guide

Step 1

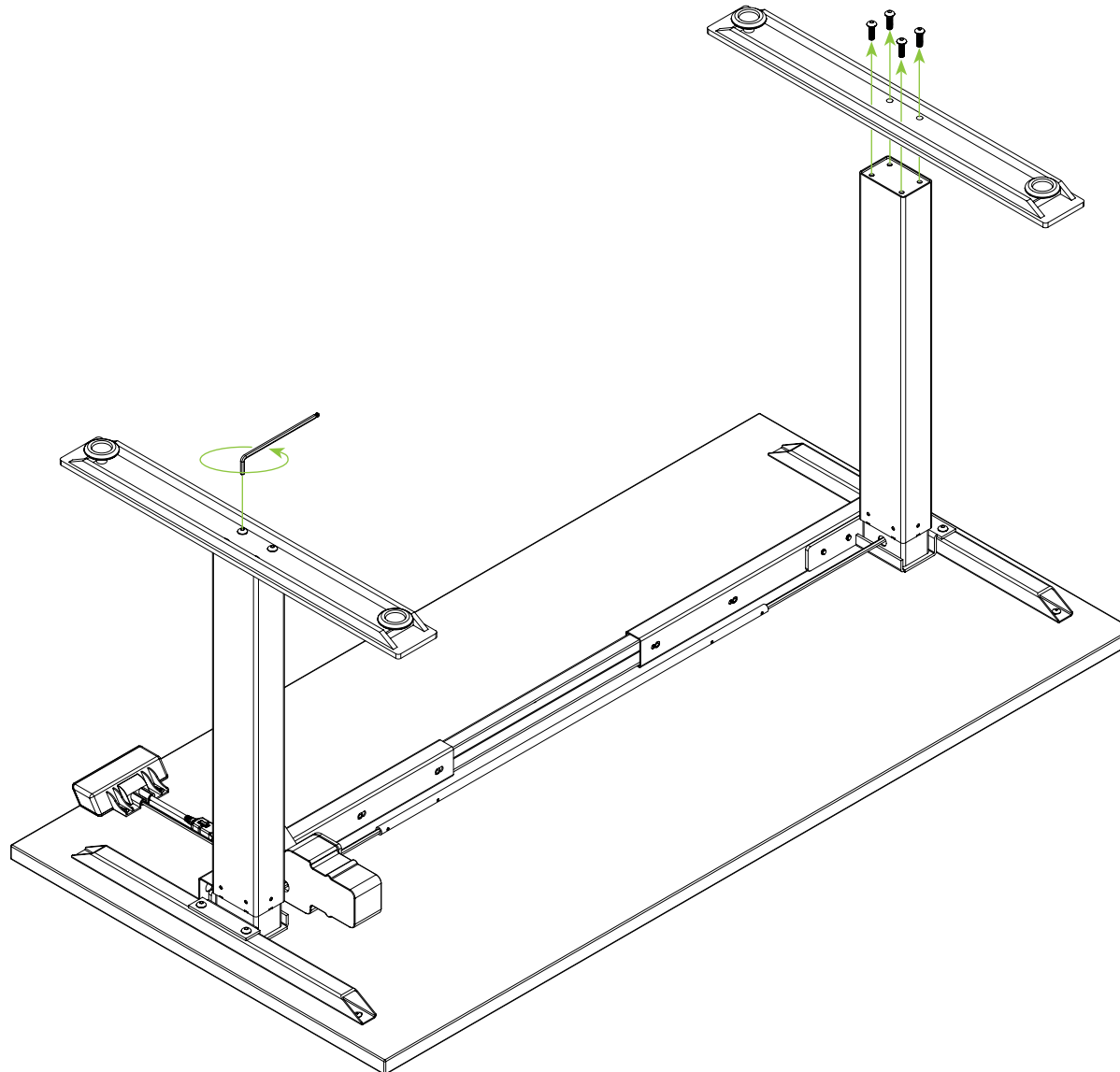

Optional Desk Hung Screen

Installation Guide

Step 2

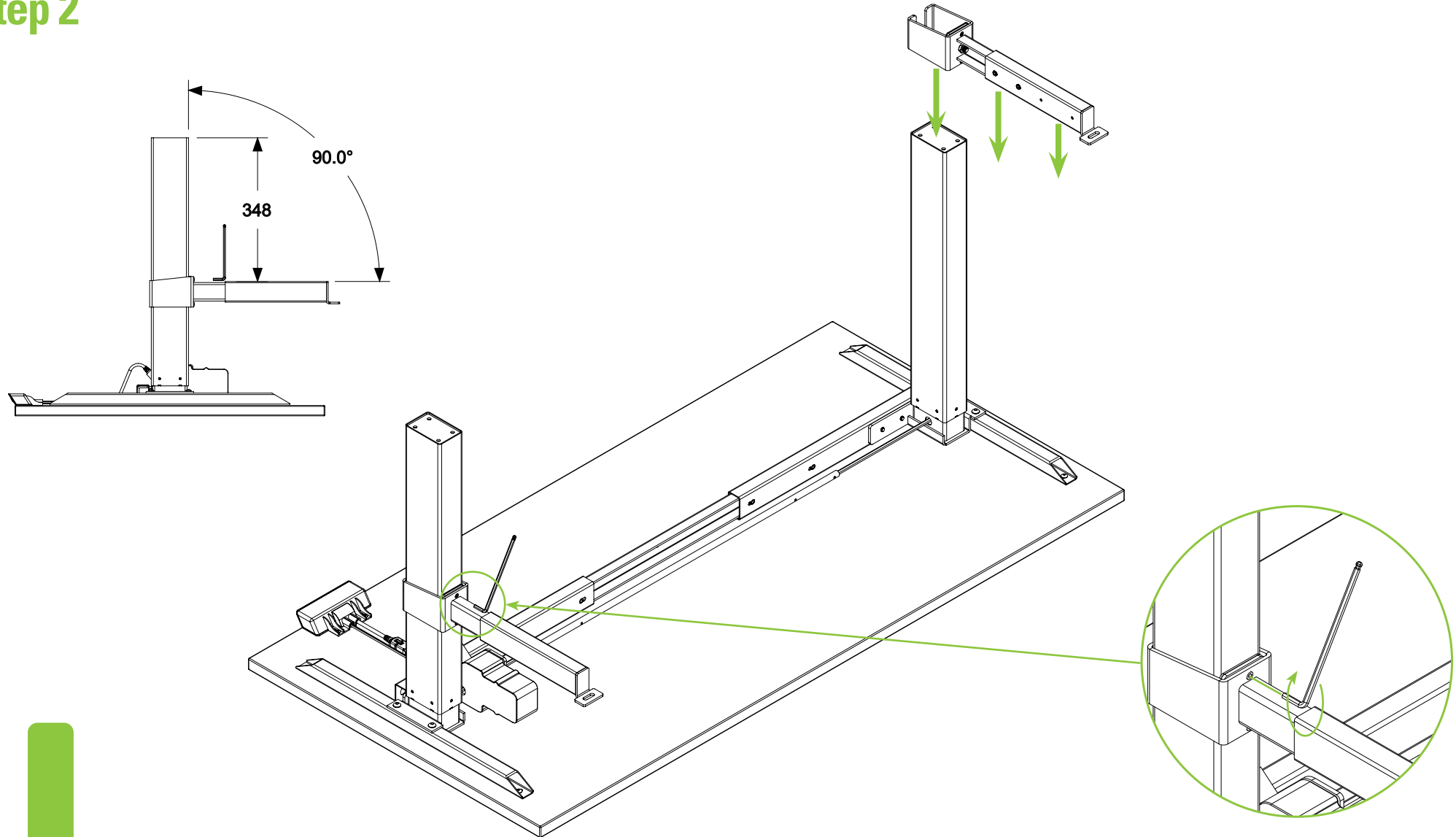

Optional Desk Hung Screen

Installation Guide

Step 3

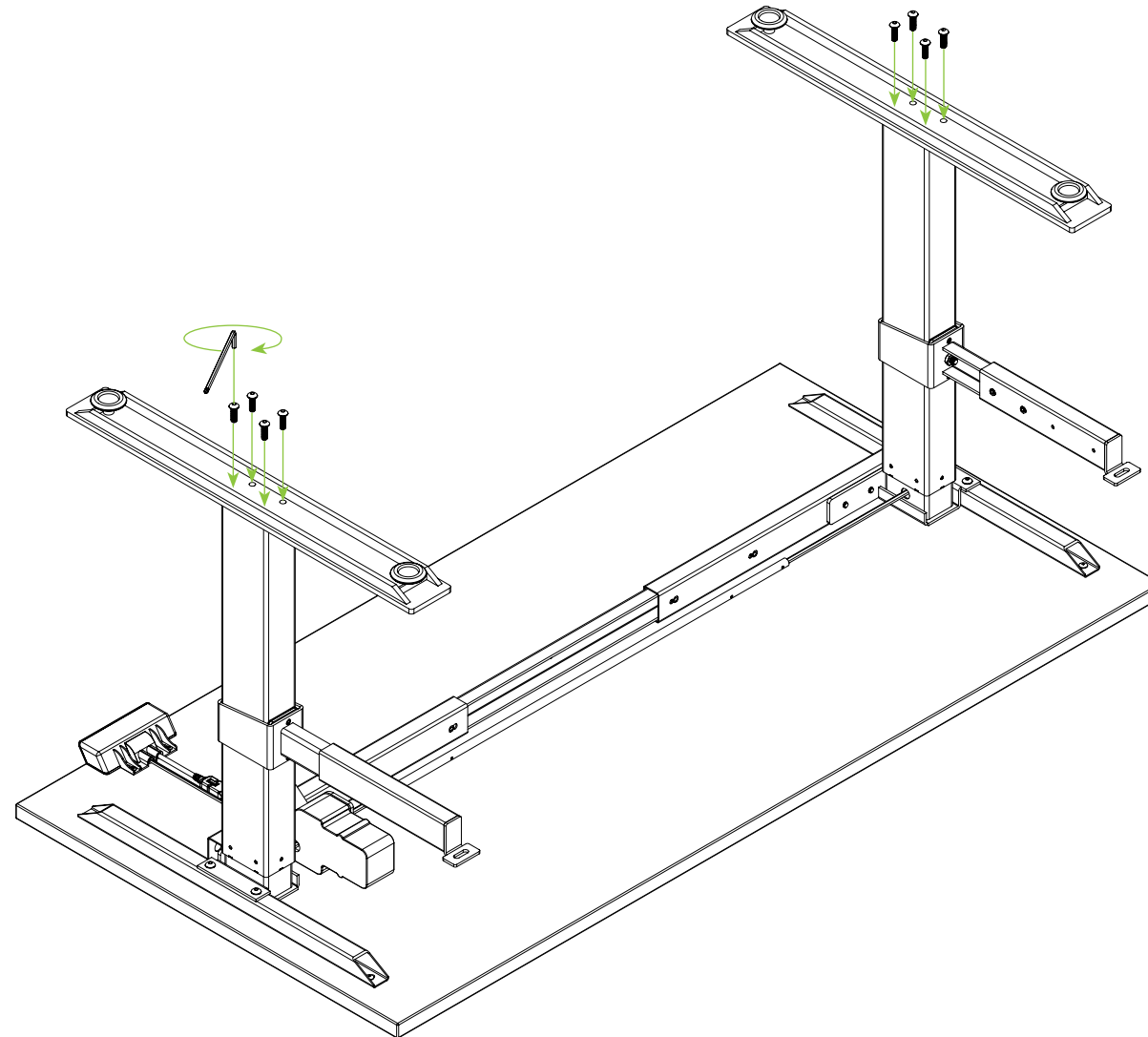

Optional Desk Hung Screen

Installation Guide

Step 4

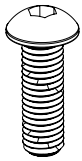

2 x M8x25

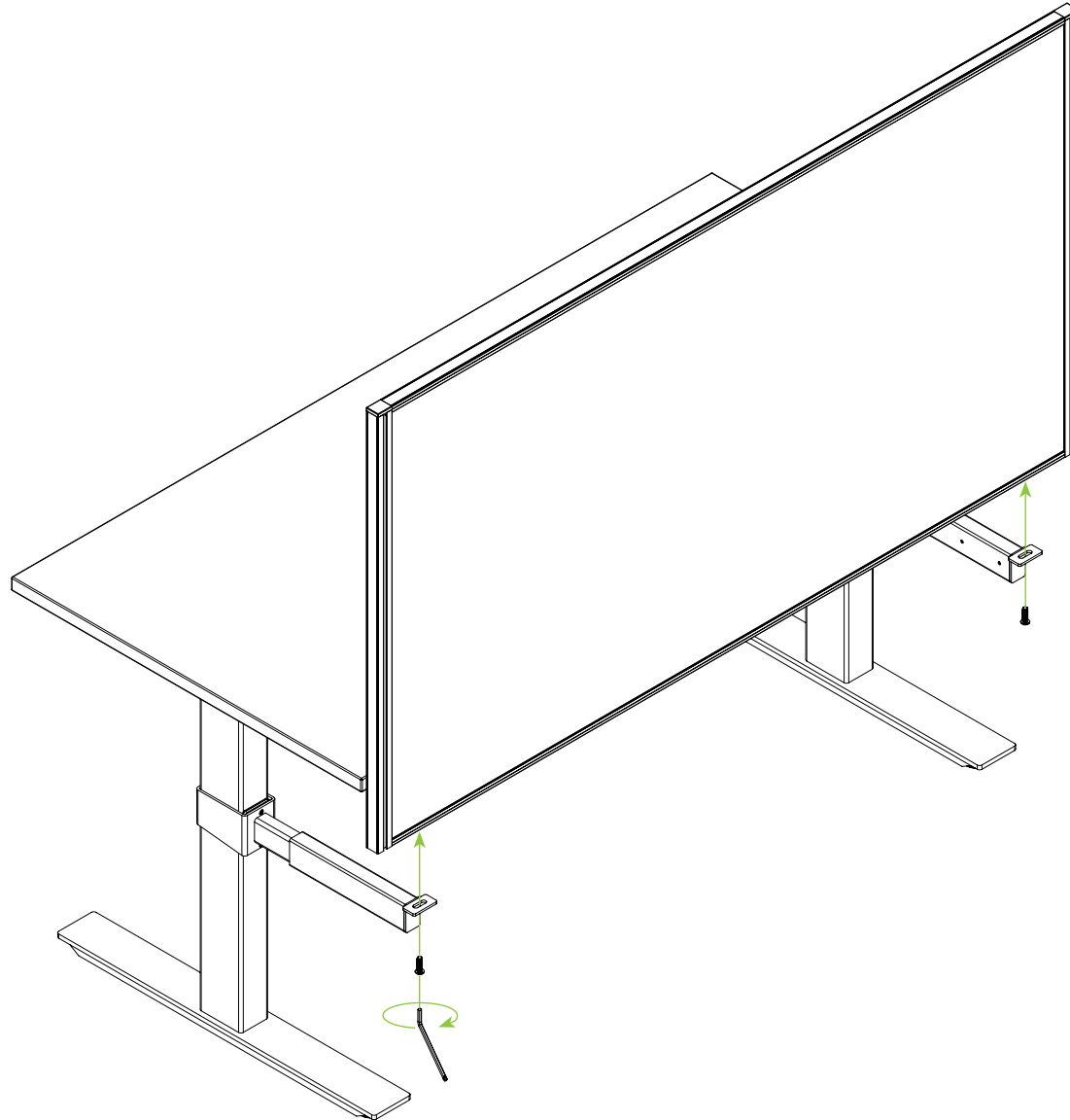

Optional Desk Hung Screen

Installation Guide

Step 5

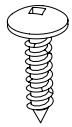

4 x ST5.0x23

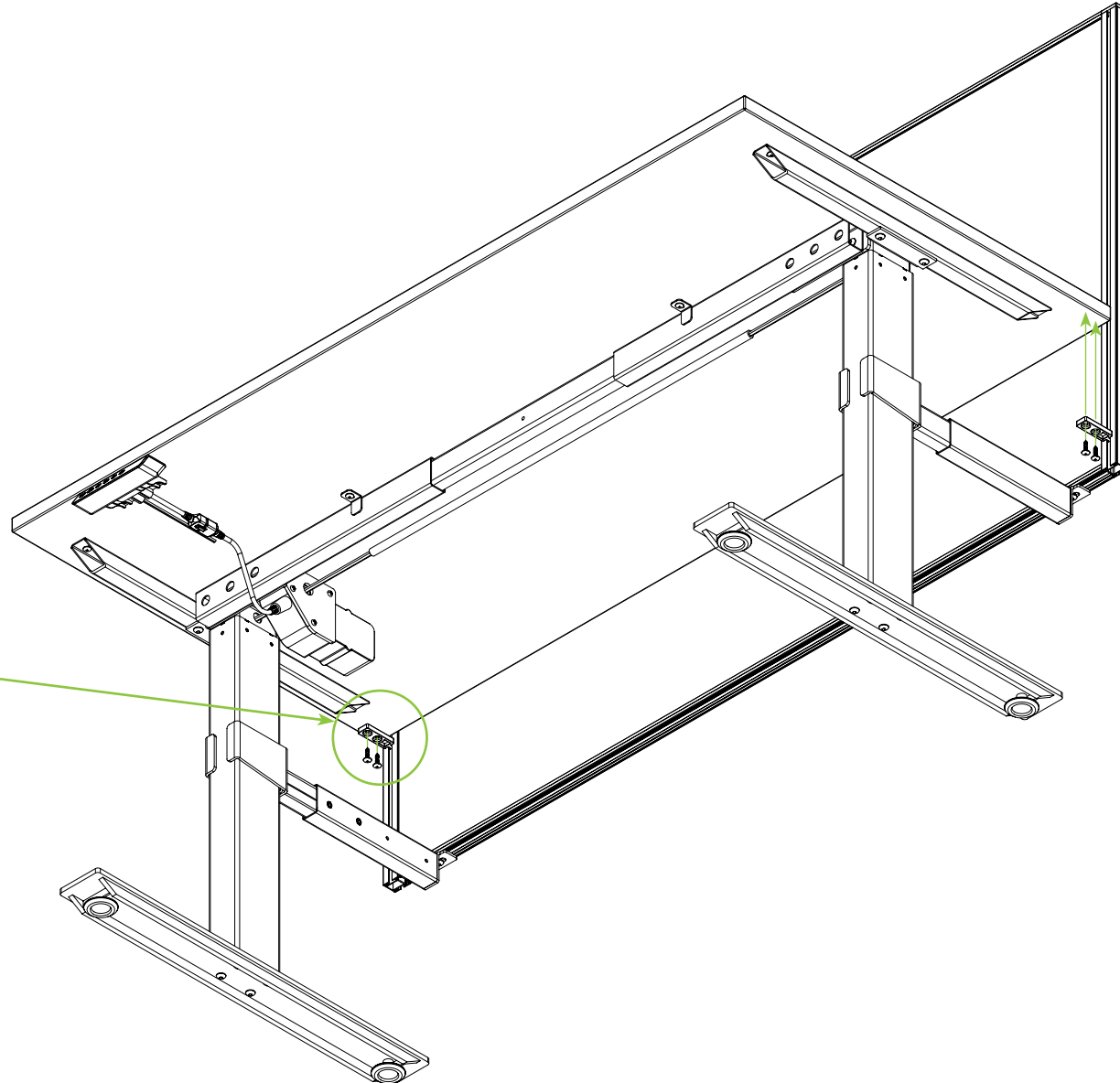
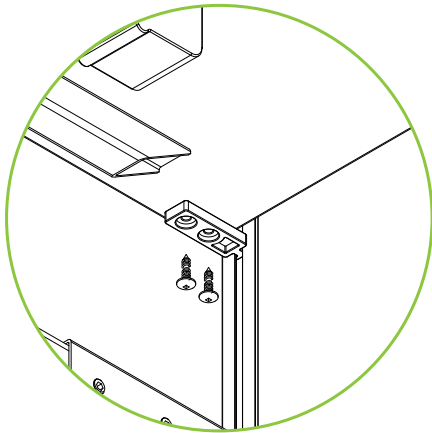

Optional Desk Hung Screen

Installation Guide

Step 6

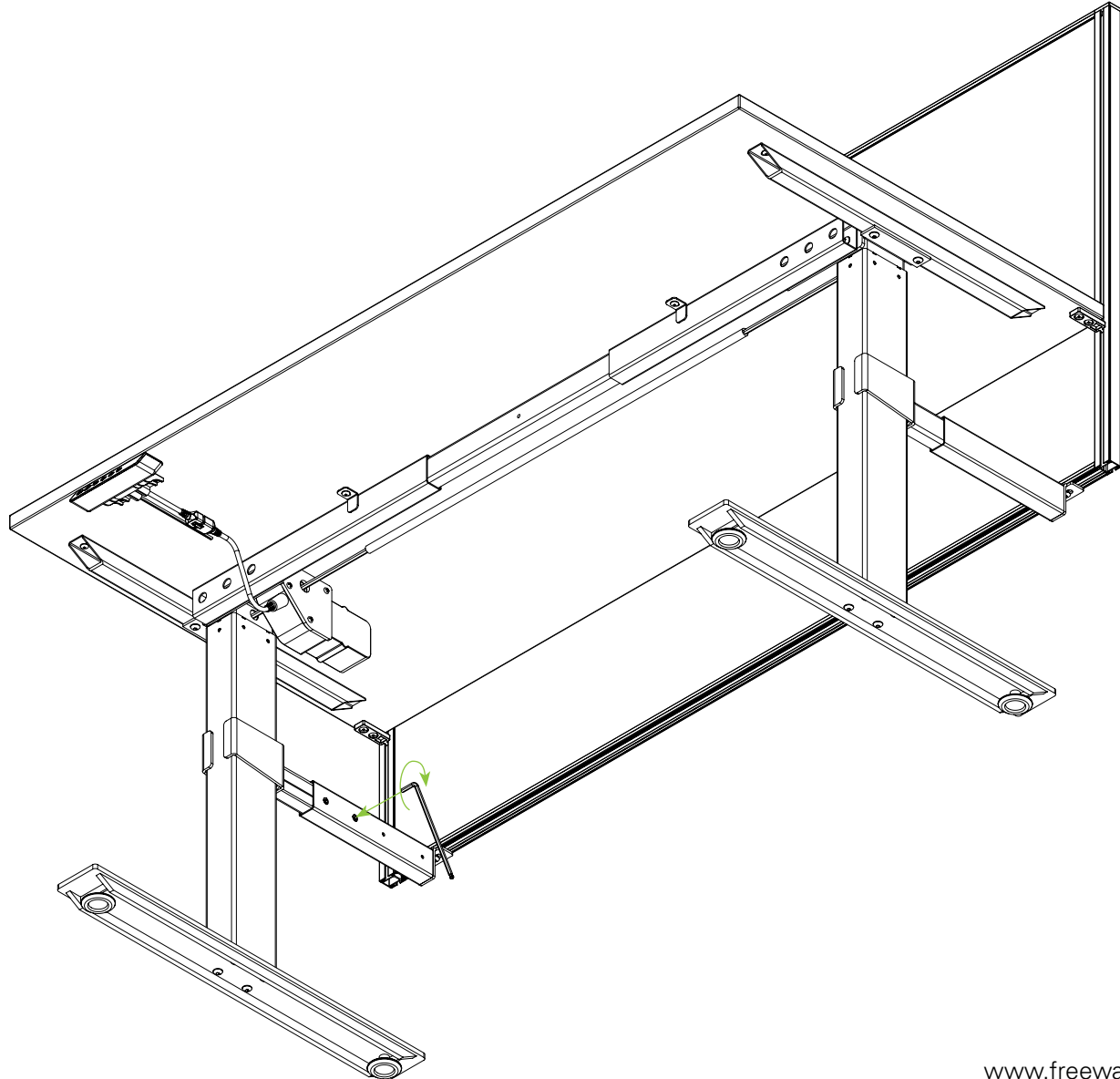
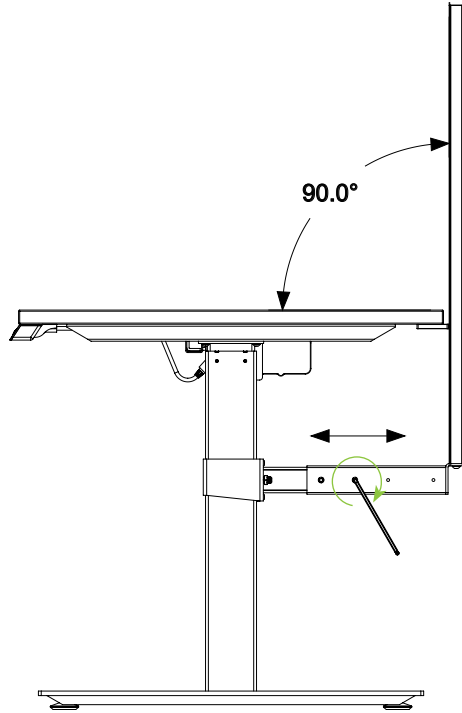

Optional Desk Hung Screen

Installation Guide

Completed

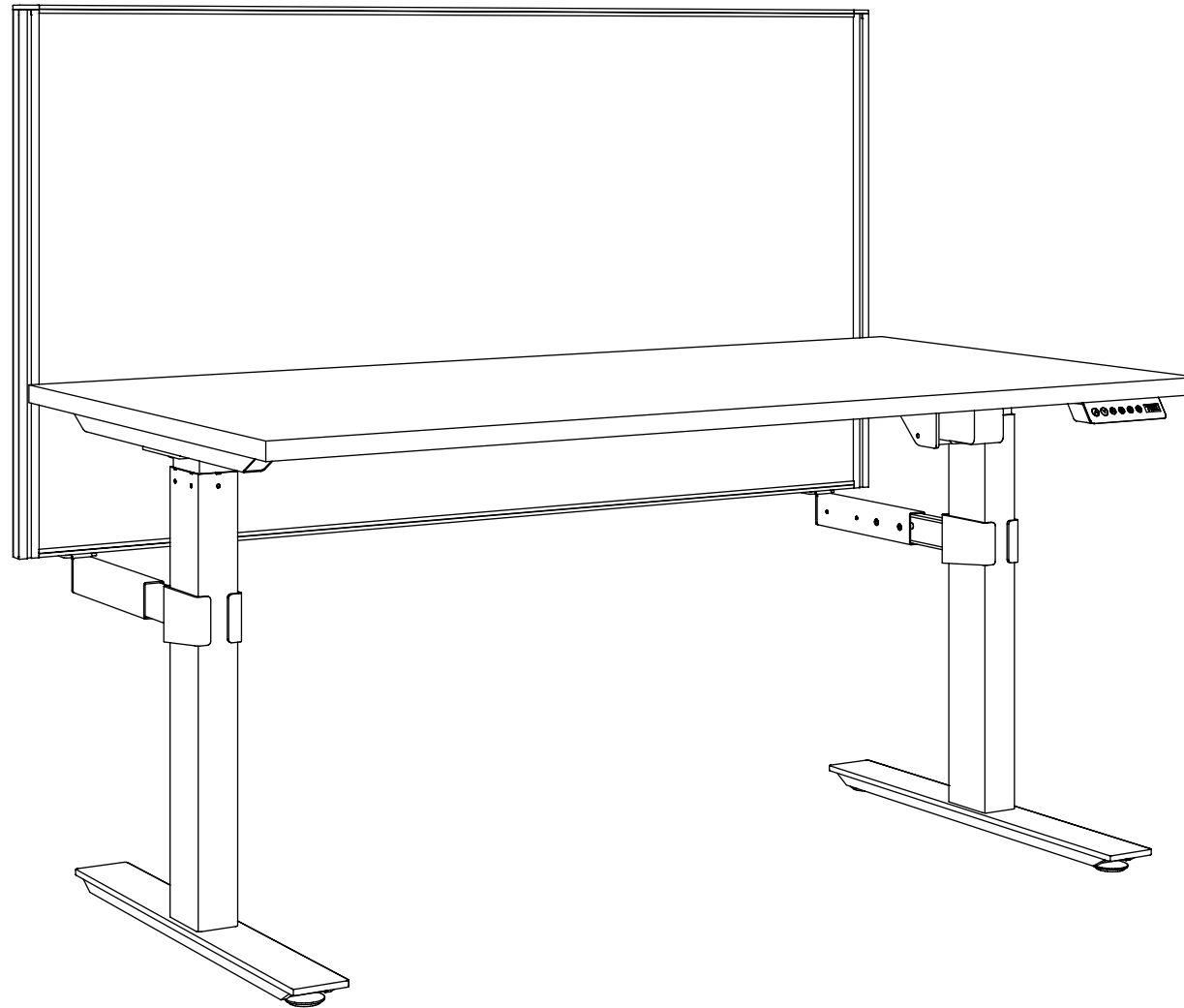

Optional Cable Tray

Installation Guide

Step 1



4 x M6x10

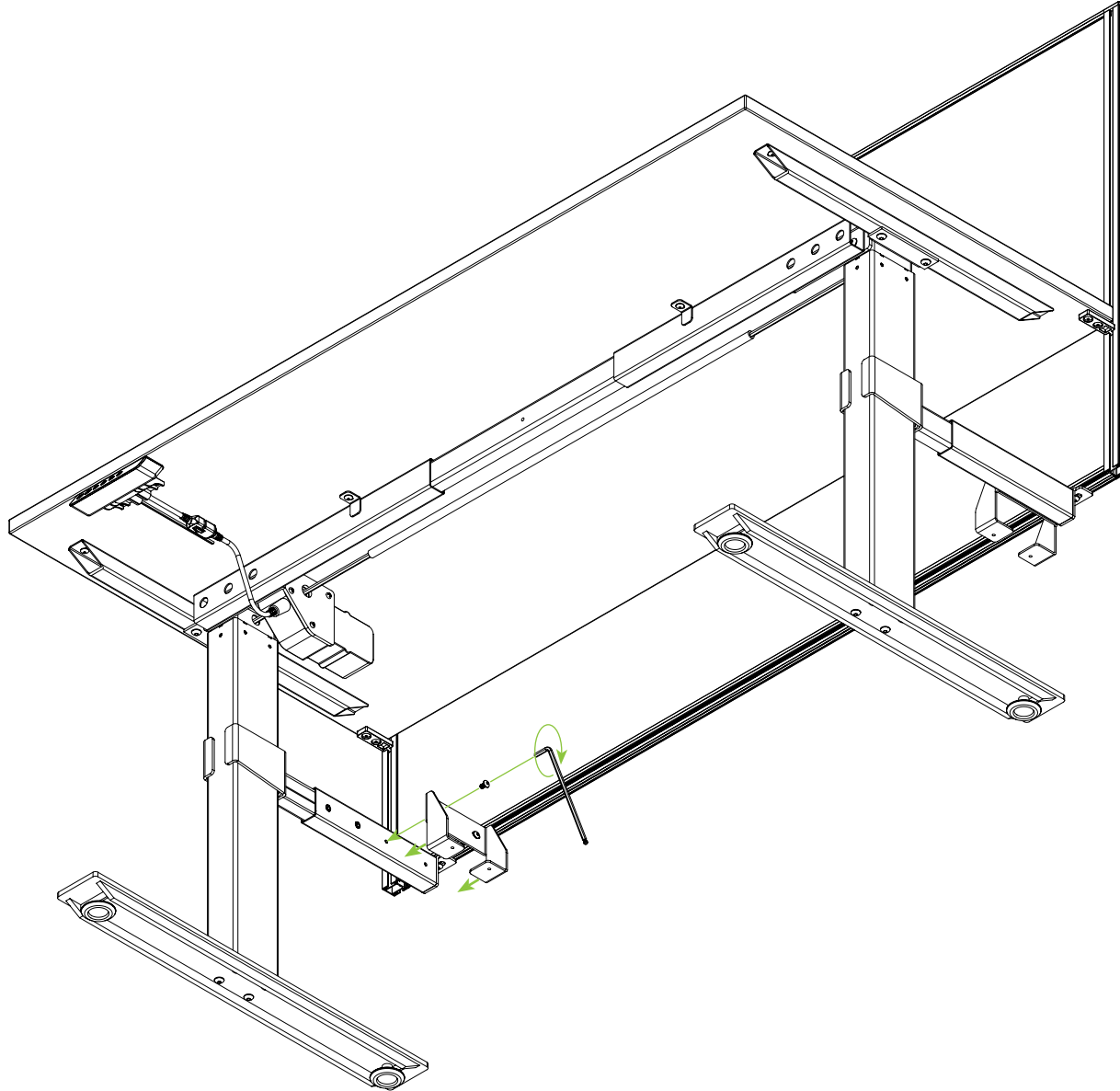

Optional Cable Tray

Installation Guide

Step 2



4 x M5x6

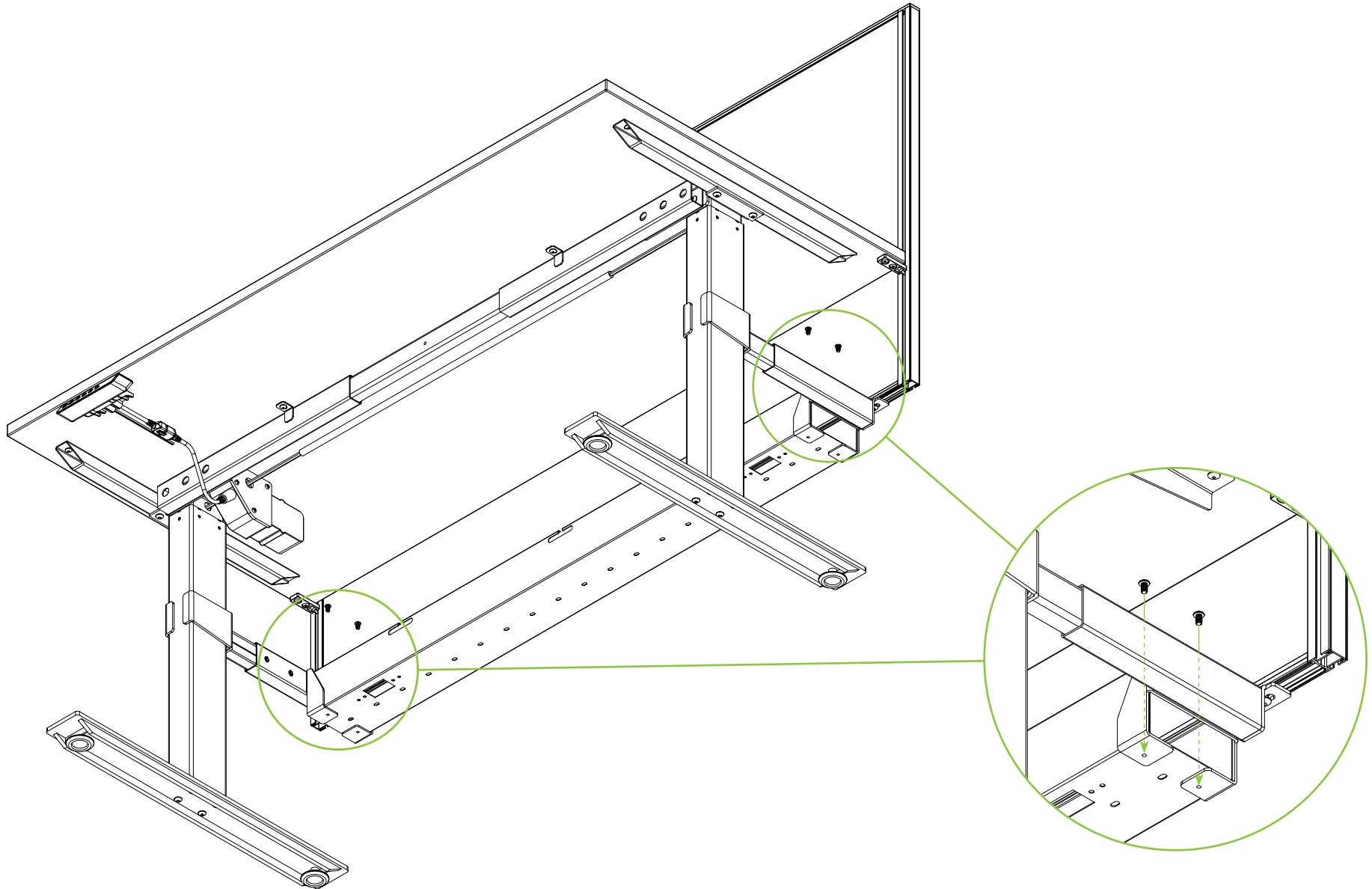

Directions For Use

IMPORTANT!

Please carefully read the assembly manual and direction for use prior to instalment, use and maintenance of the table frame to gain a complete understanding of its contents. It provides you with important information about the safety, use, installation and maintenance of the table.

WARNING: FAILURE TO COMPLY WITH OR OBSERVE ALL ASSEMBLY, SAFETY AND OPERATION INSTRUCTIONS REGARDING THE USE OF THIS PRODUCT MAY RESULT IN SERIOUS BODILY INJURY.

SAFETY

- The table must be used in a safe manner. Inappropriate use may cause damage to the table and/or cause bodily harm to the user or persons nearby.
- Do not tamper with electrical components as this may lead to serious bodily harm.
- Only connect the electric table frames to the prescribed mains power voltage.
- Do not use the table frame to lift people.
- Please retain this operation manual and pass it on to any future owner.

USAGE

- The height-adjustable table is designed for use in dry work environments only.
- The table height is infinitely adjustable within its height range so that it can be set to the user's most ergonomic working height. The user should seek professional help to establish their optimum working height.
- The table has been designed as a devise to elevate the users work surface and associated office peripherals. Do not use the table frame for any other purposes than that which it has been designed for. Any other use is at user's own risk!
- Do not crawl, lie or move around under the table frame, and do not sit or stand on the table frame.
- CHILDREN should only use the table when supervised by adults.
- Liability: The manufacturer accepts under no circumstances warranty claims or liability claims for damages arising from improper use or handling of the table frame other than that described in this operation manual.

SET UP AND INSTALLATION

Assemble the table frame according to the assembly instructions on pages 4 - 12.

- Place the table in a safe distance from window frames, radiators, furniture etc. so that persons cannot become trapped.
- Level the table with the adjustable feet ensuring that the table is stable.
- Check that no cables can get jammed.
- Connect the table to the 110 or 230 VAC power outlet.

The table is now ready for use.

MAINTENANCE

- The table does not require any maintenance by the user
- The table is only to be cleaned with a wrung cloth.

TECHNICAL DATA

Height Range: 680-1130mm including worktop

Speed: ~22mm/s

Input Voltage: 100-240V AC 50-60Hz

Output Voltage: 24V DC 2.0A

Duty Cycle: 10% 2min on 18min off

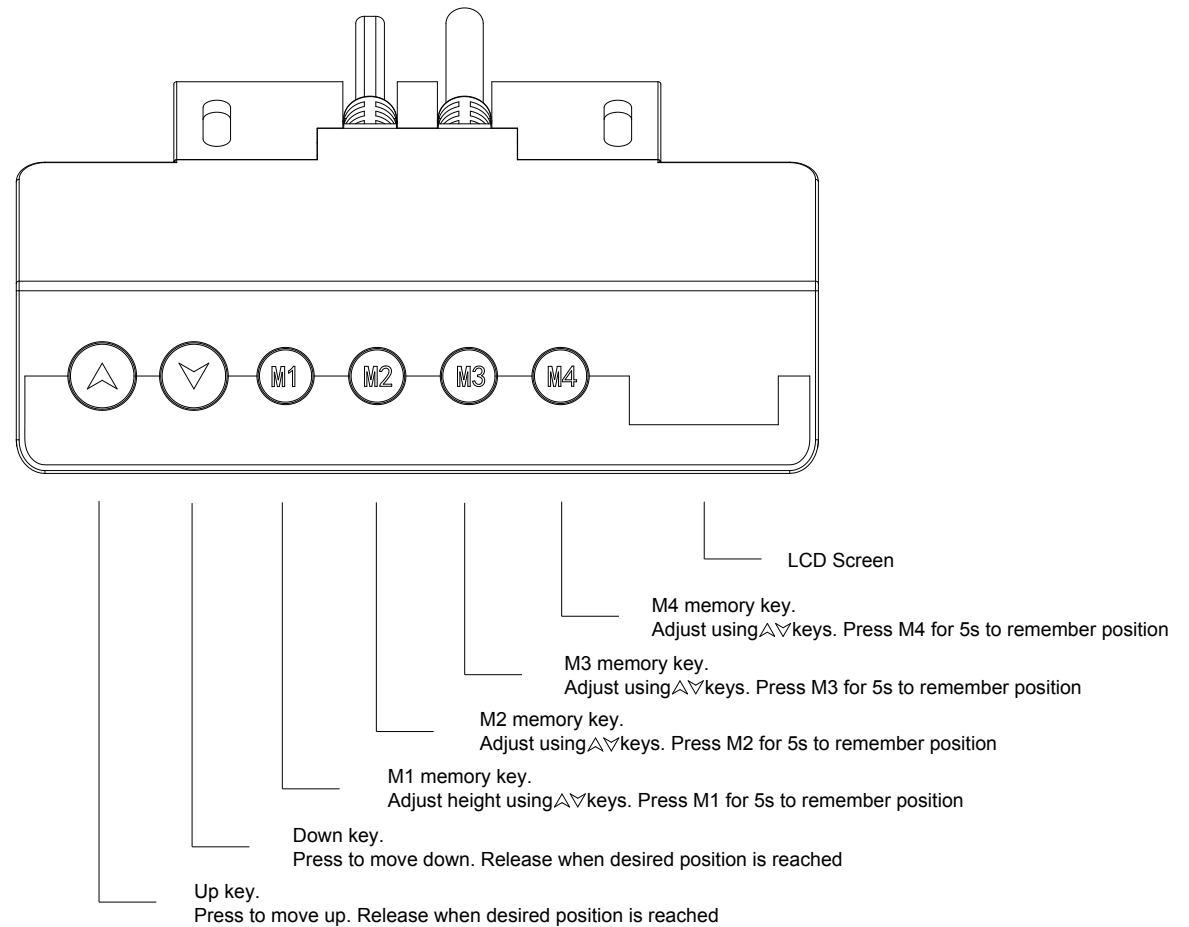



freeway

Agile

Installation Guide - Electric 3 Column

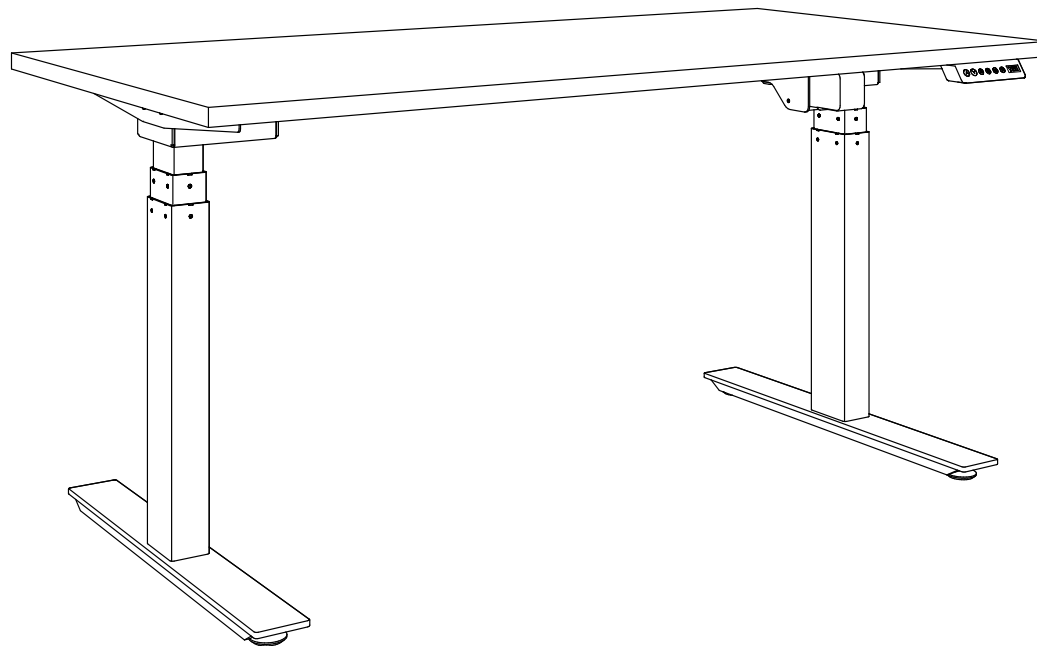

Parts:

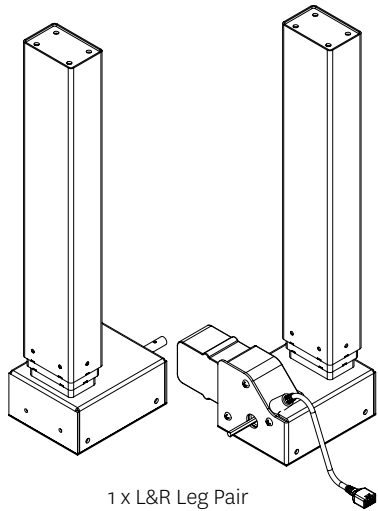

1 x L&R Leg Pair

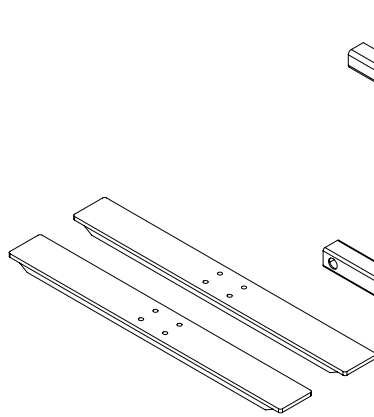

2 x Foot

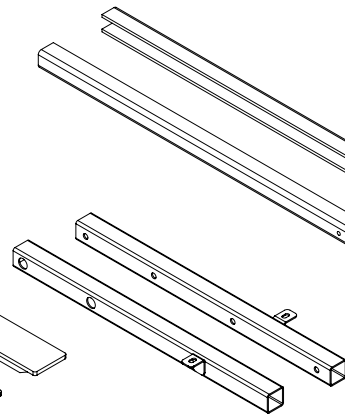

1 x L&R Leg Rail Pair

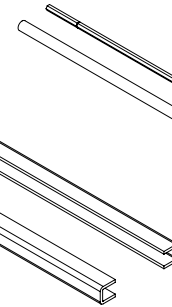

2 x Cross Rail

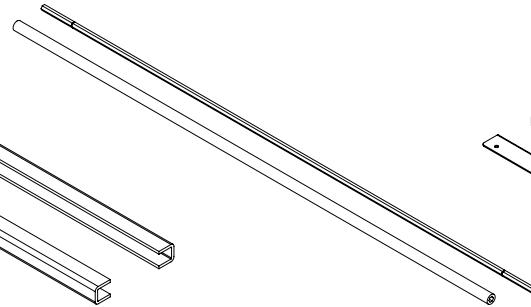

1 x Drive Shaft

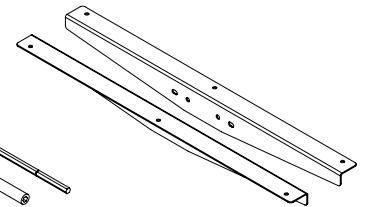

1 x L&R Support Bar Pair

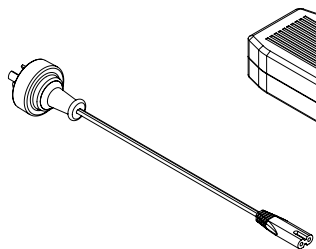

1 x Power Cord

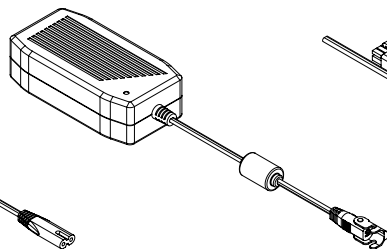

1 x Power Supply

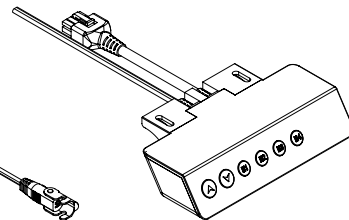

1 x Handset

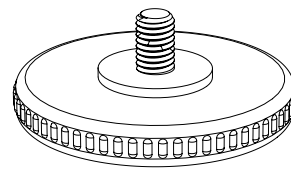

4 x Levelling Foot

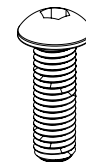

8 x M8x25



12 x M8x10



8 x ST5.0x23



2 x ST3.9x13

Step 1



8 x M8x10

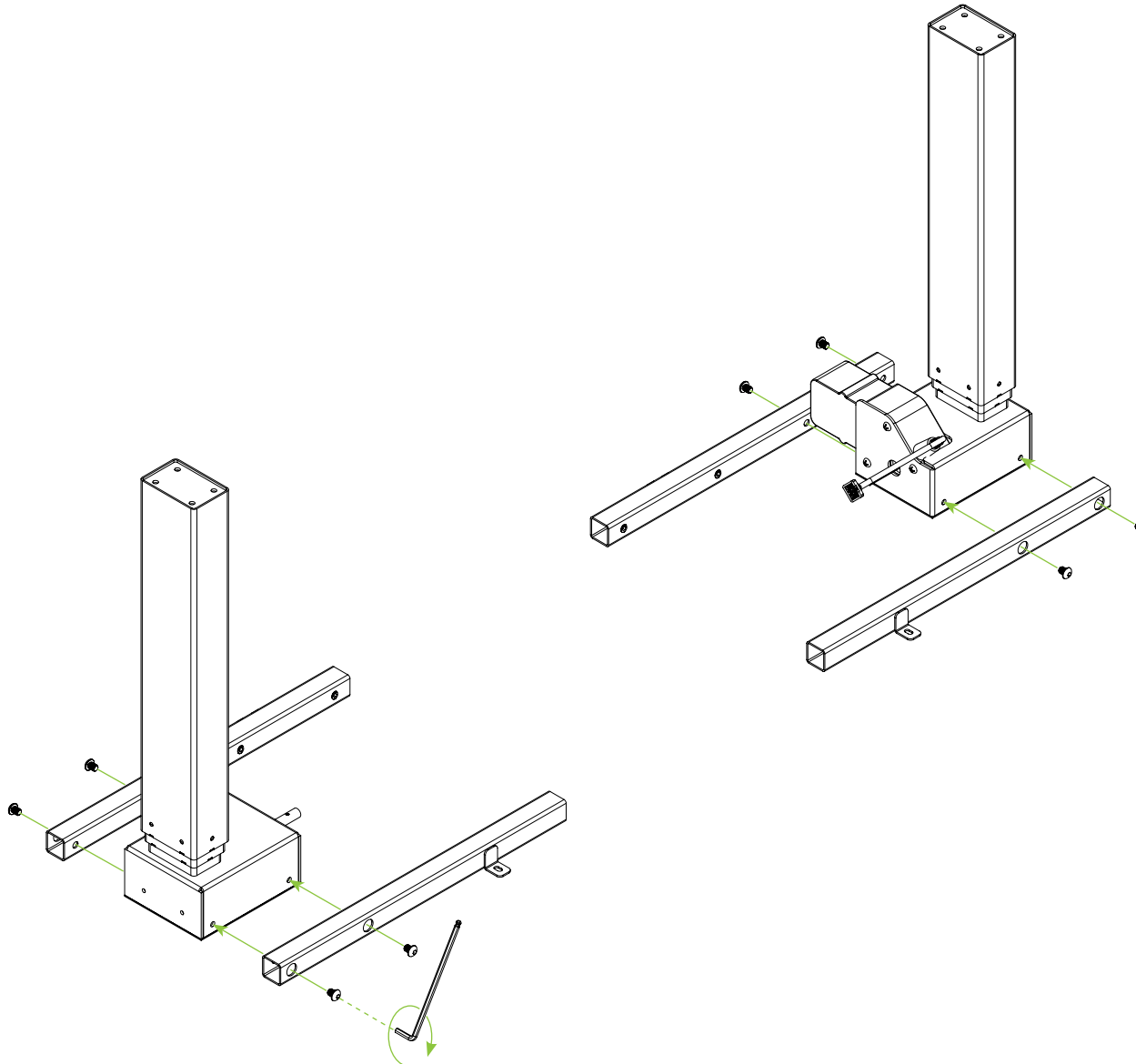

Step 2



4 x M8x10

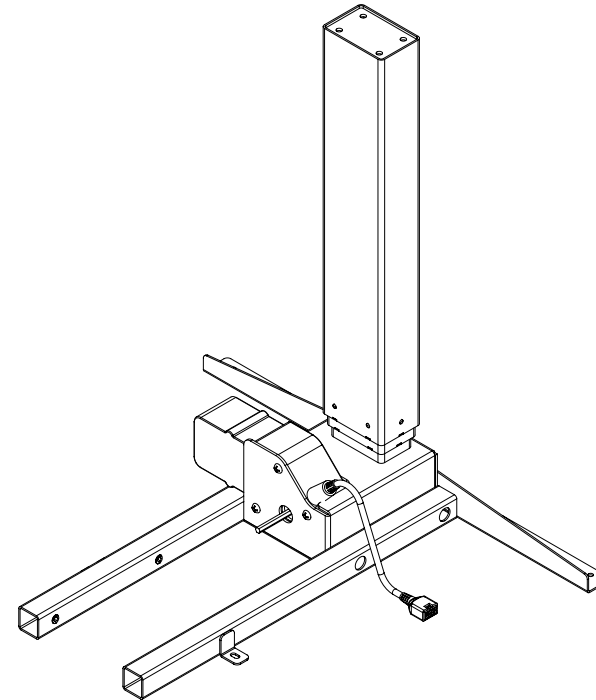
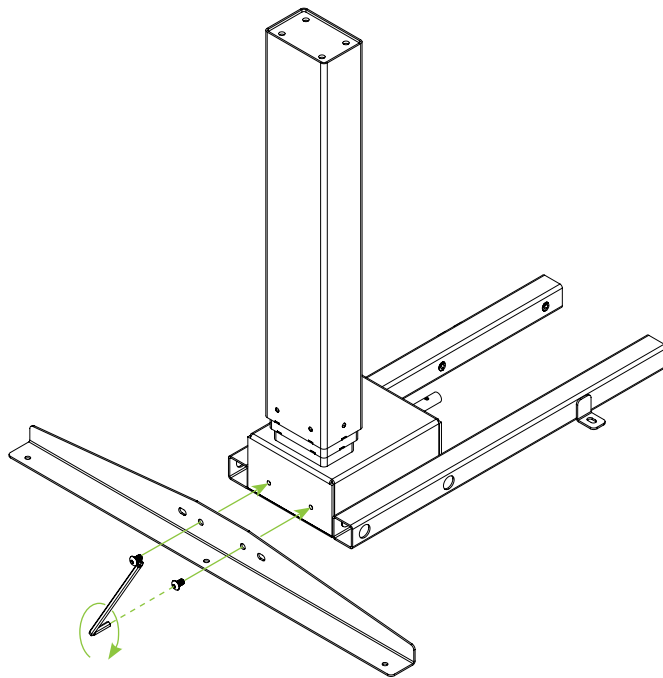

Step 3

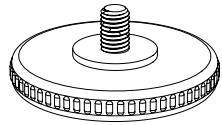

4 x Levelling Foot

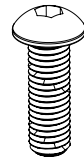
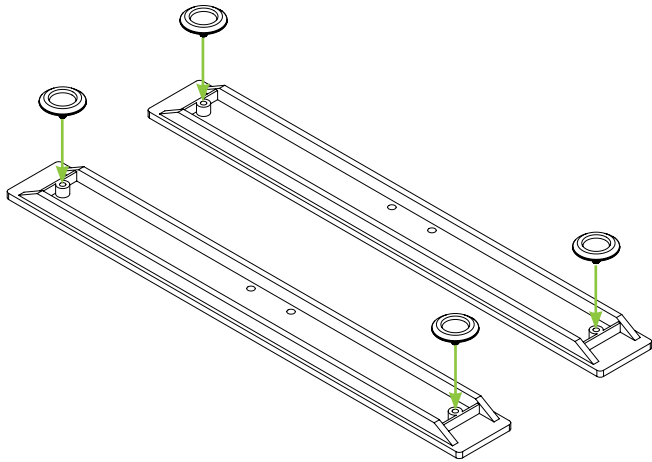

8 x M8x25

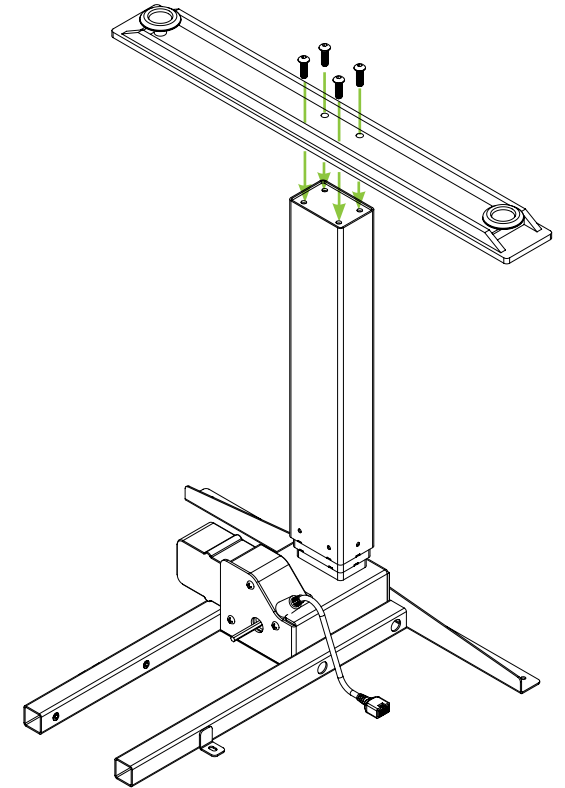
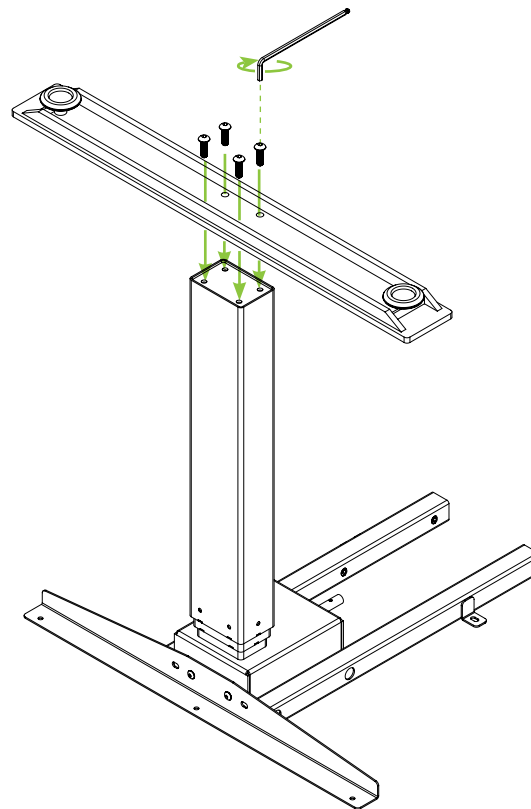

Step 4

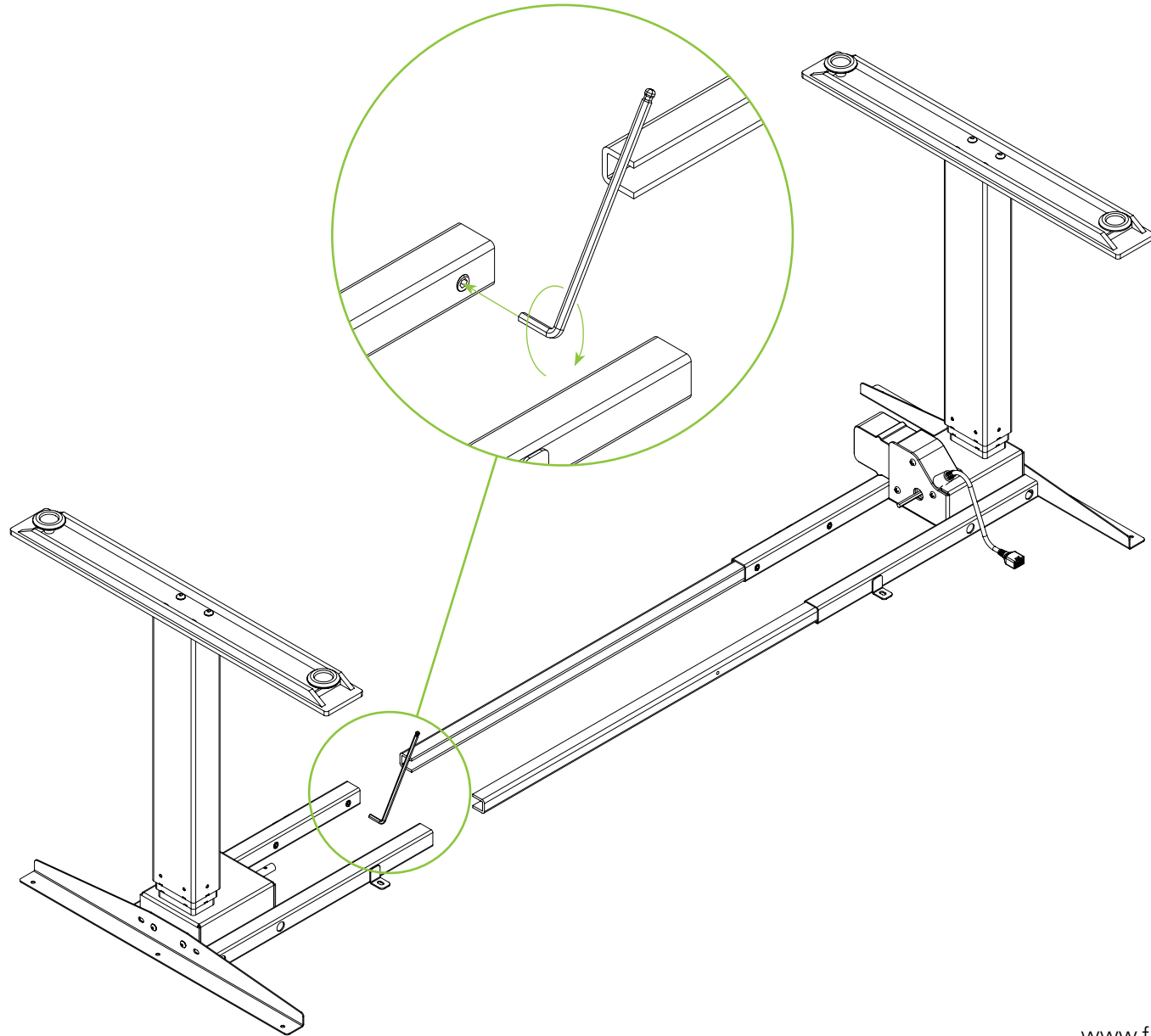

Step 5

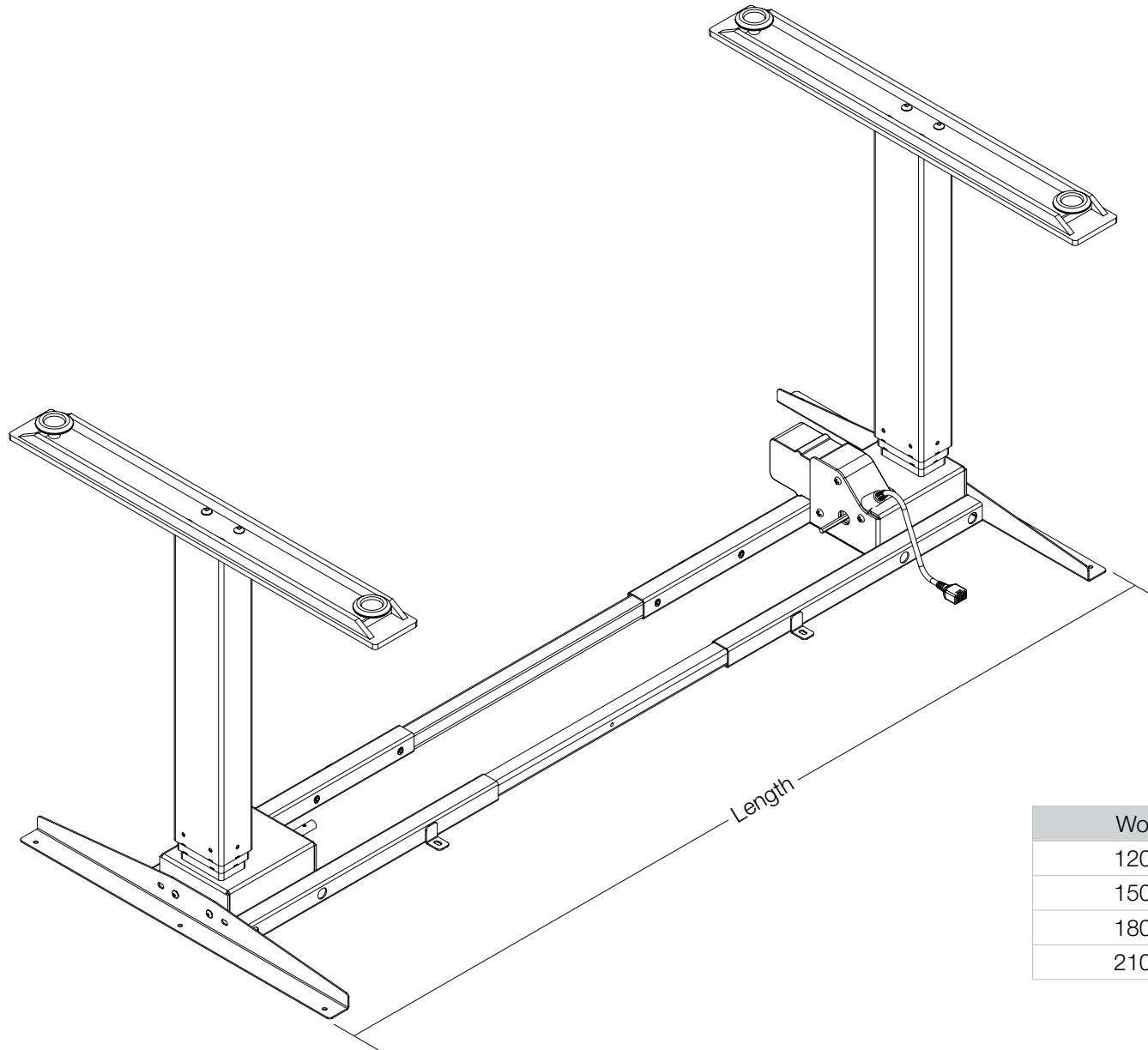

Worktop	Length
1200mm	1125mm
1500mm	1425mm
1800mm	1725mm
2100mm	2025mm

Step 6

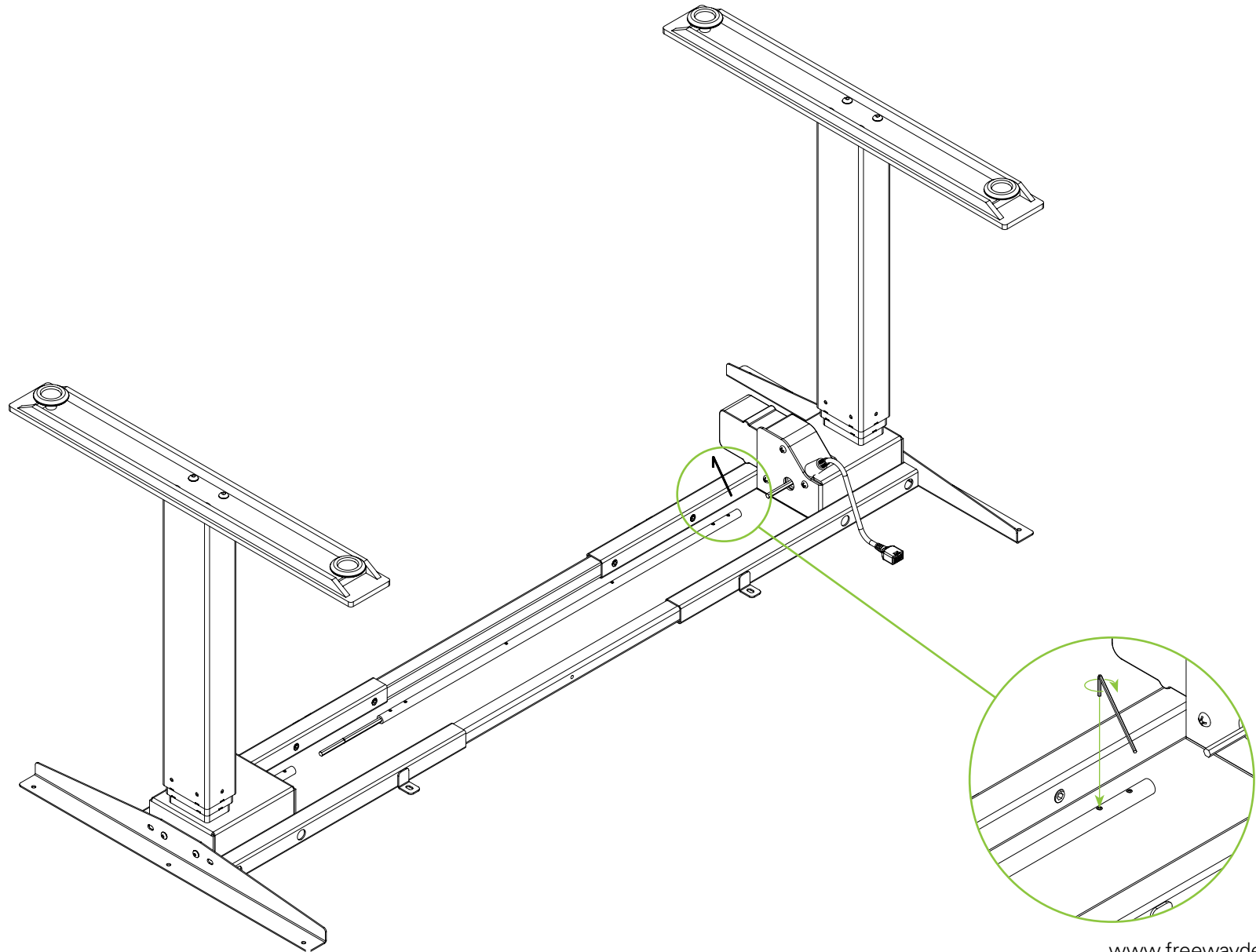

Step 7

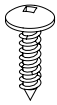

8 x ST5.0x23

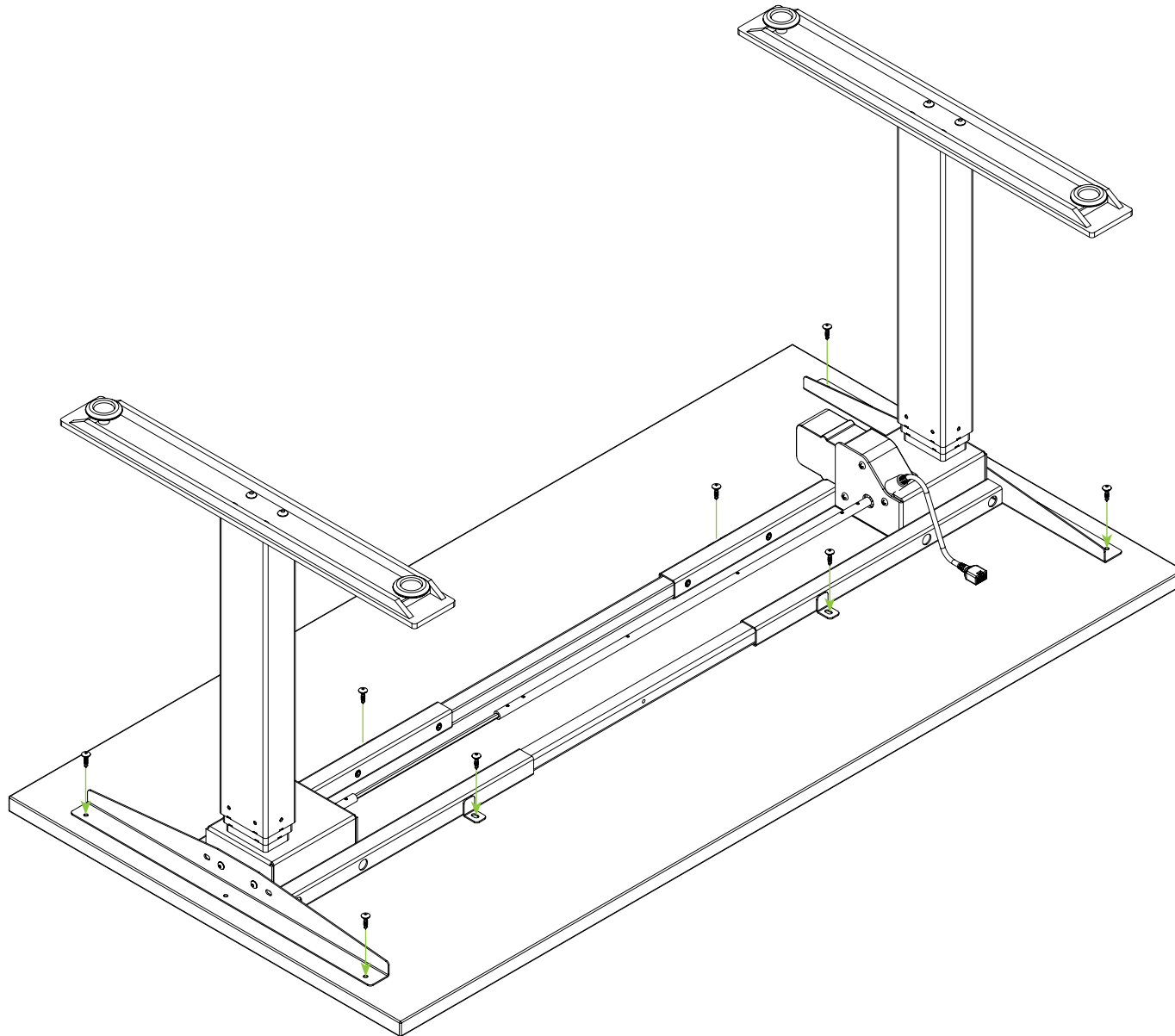

Step 8



2 x ST3.9x13

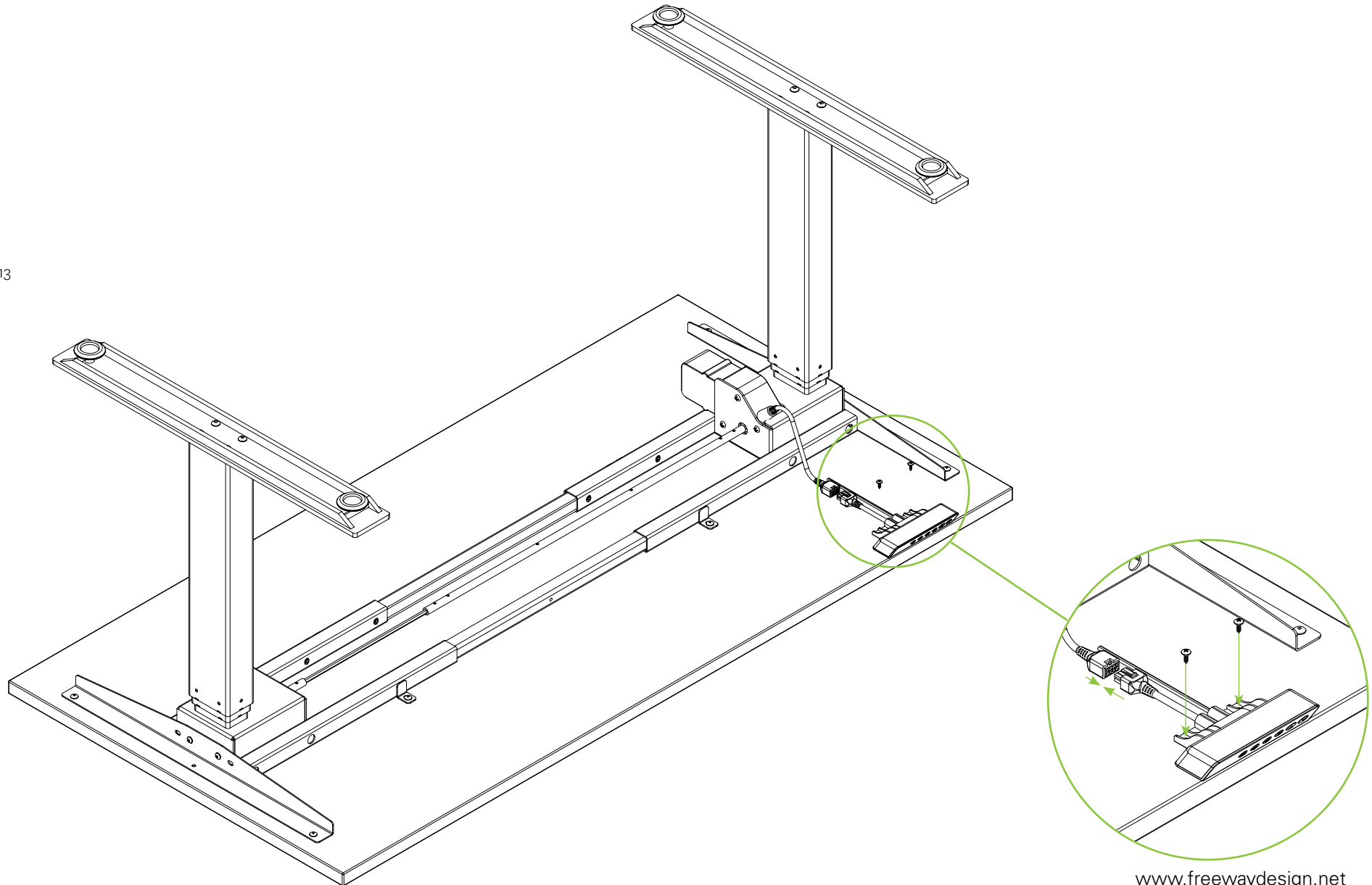

Step 9

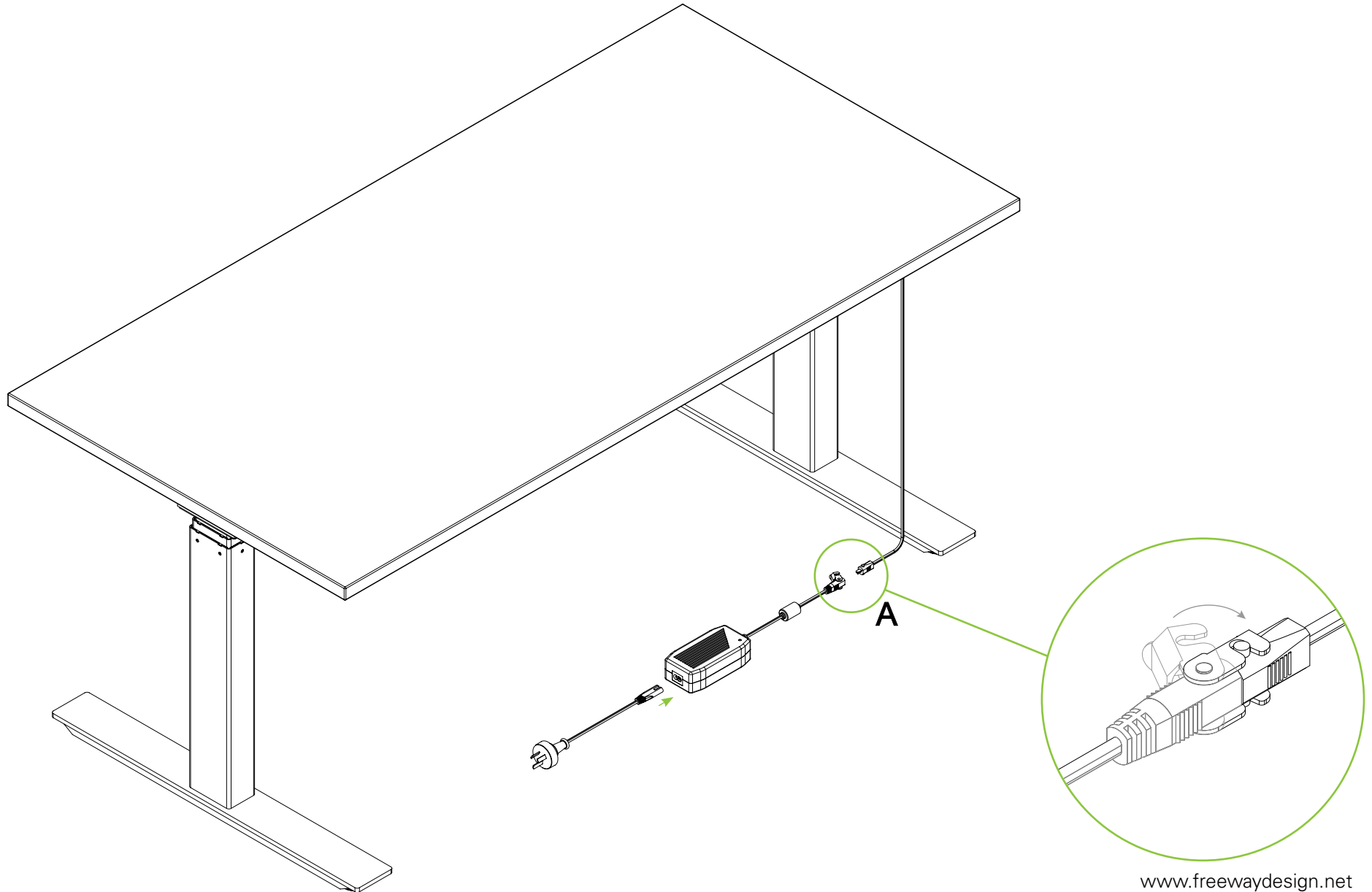

Completed

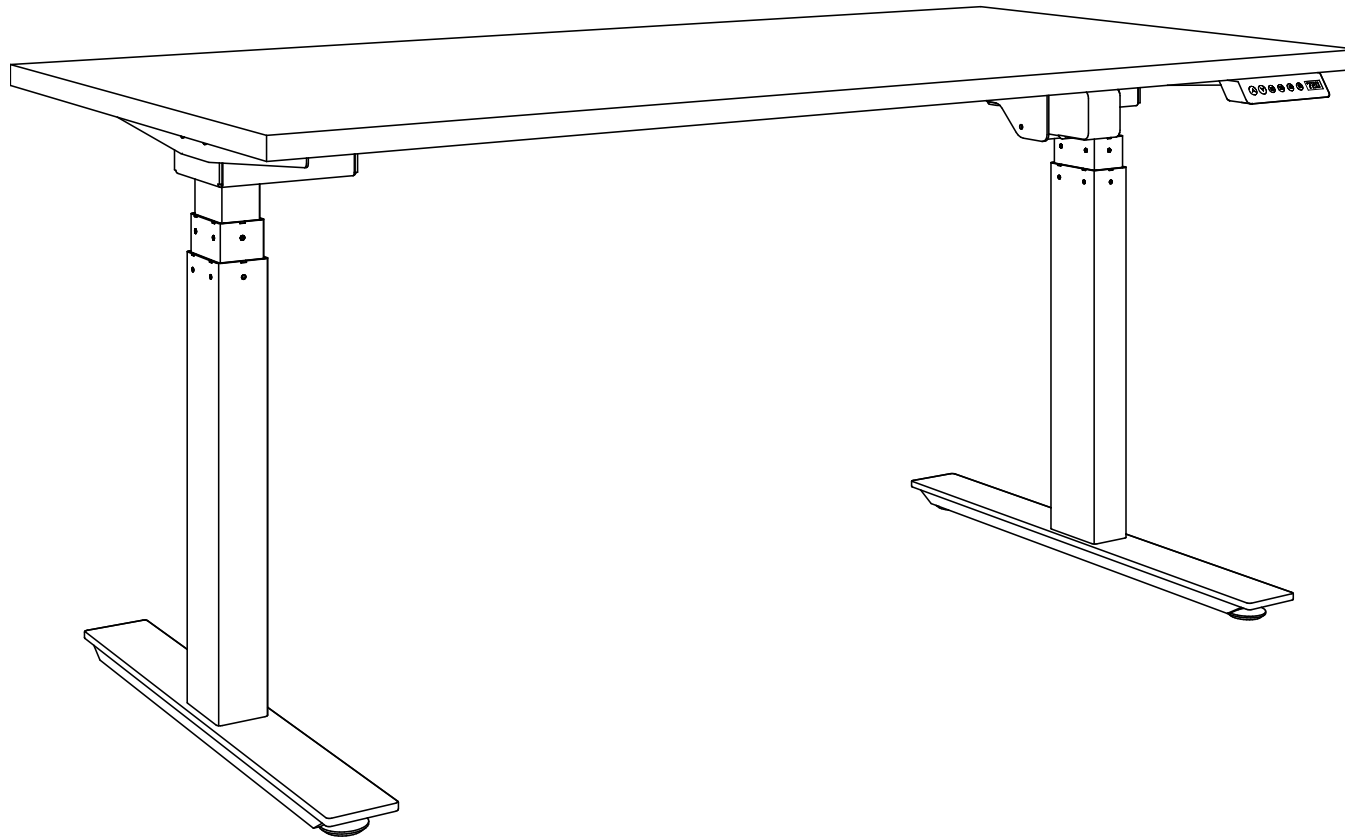

Optional Desk Hung Screen

Installation Guide

Step 1

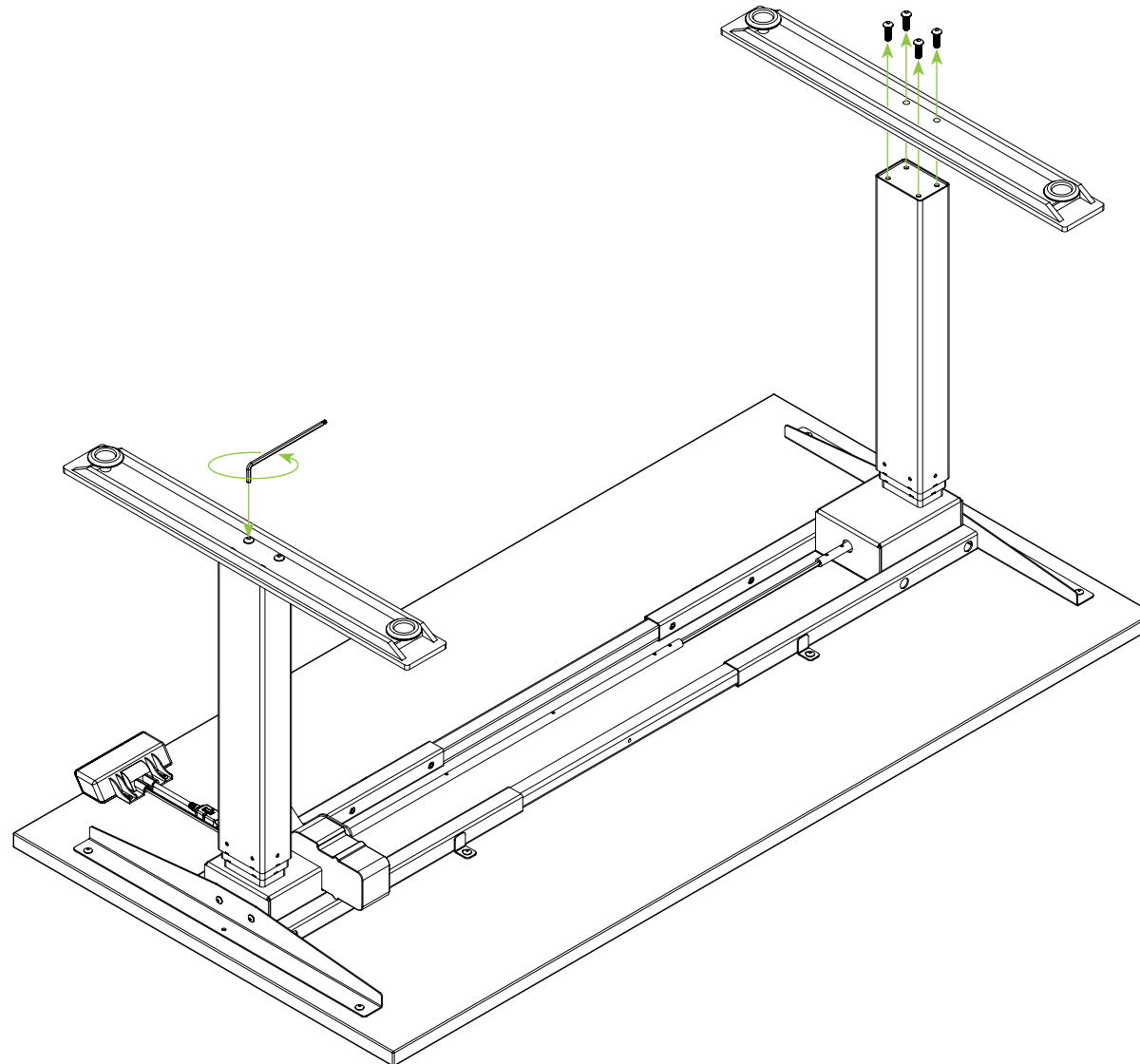

Optional Desk Hung Screen

Installation Guide

Step 2

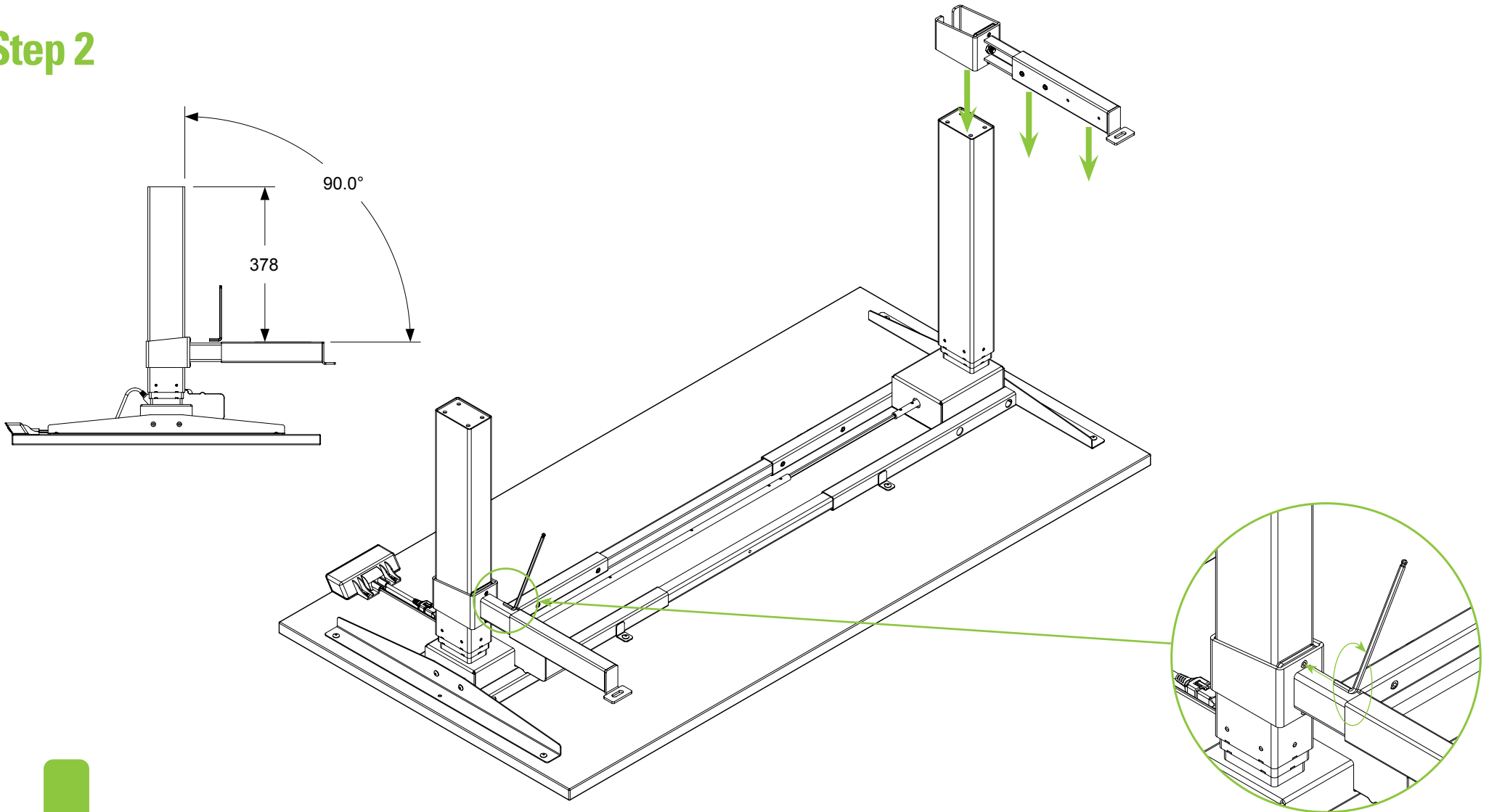

Optional Desk Hung Screen

Installation Guide

Step 3

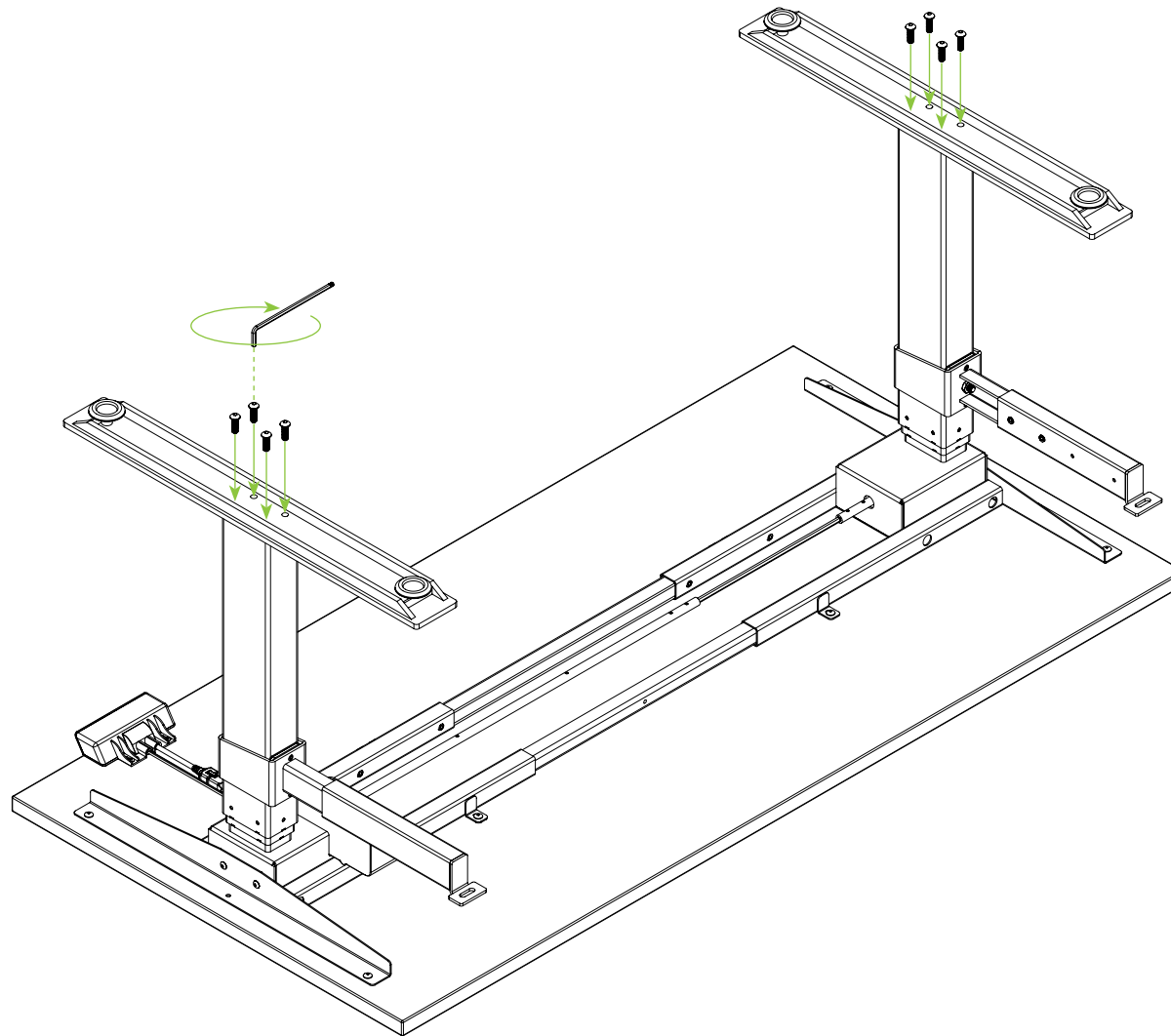

Optional Desk Hung Screen

Installation Guide

Step 4

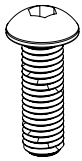

2 x M8x25

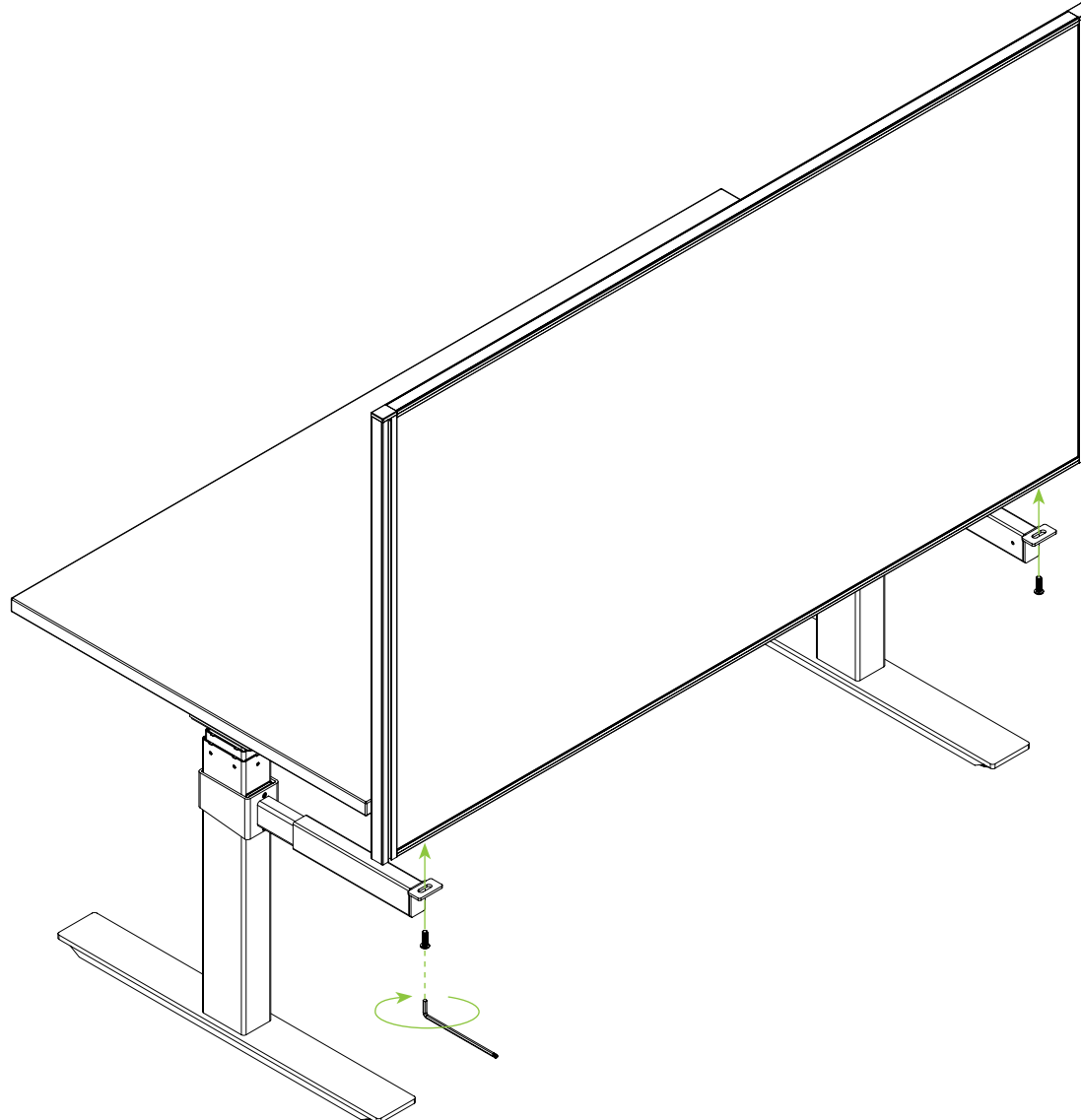

Optional Desk Hung Screen

Installation Guide

Step 5

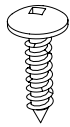

4 x ST5.0x23

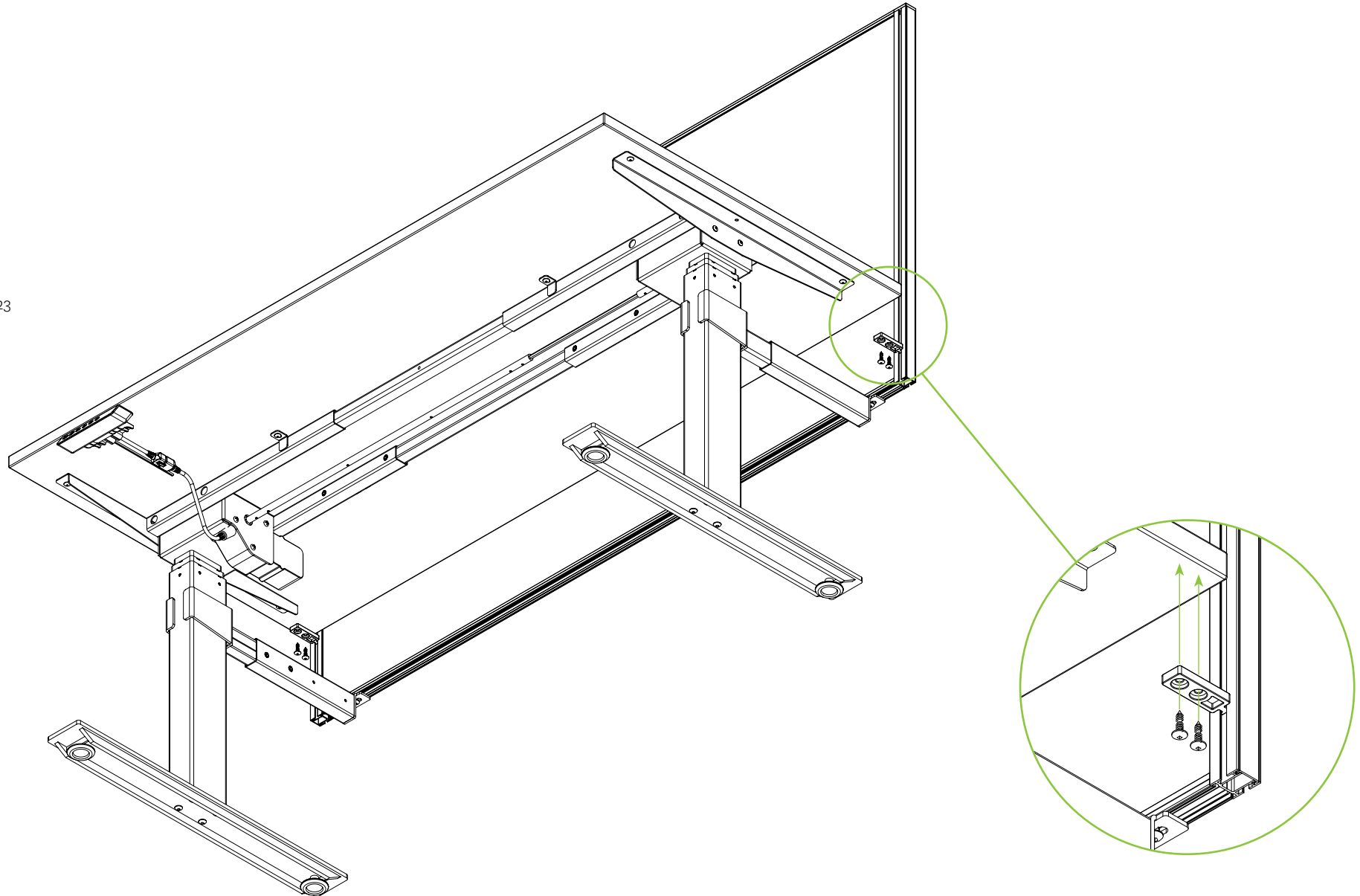

Optional Desk Hung Screen

Installation Guide

Step 6

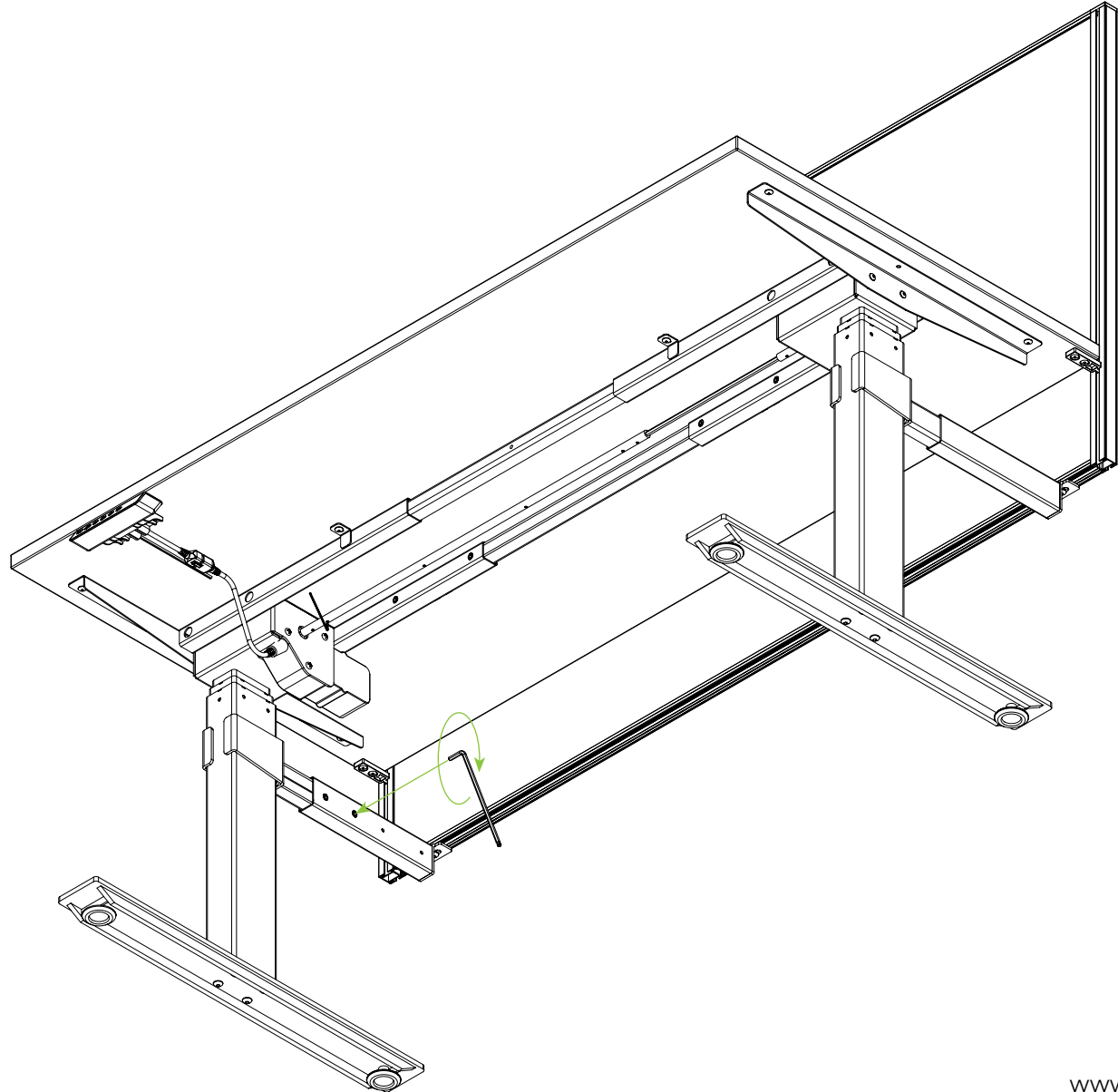
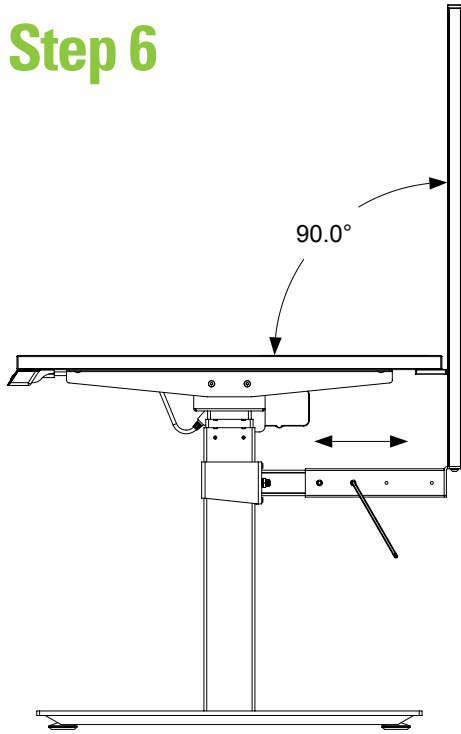

Optional Cable Tray

Installation Guide

Step 1



4 x M6x10

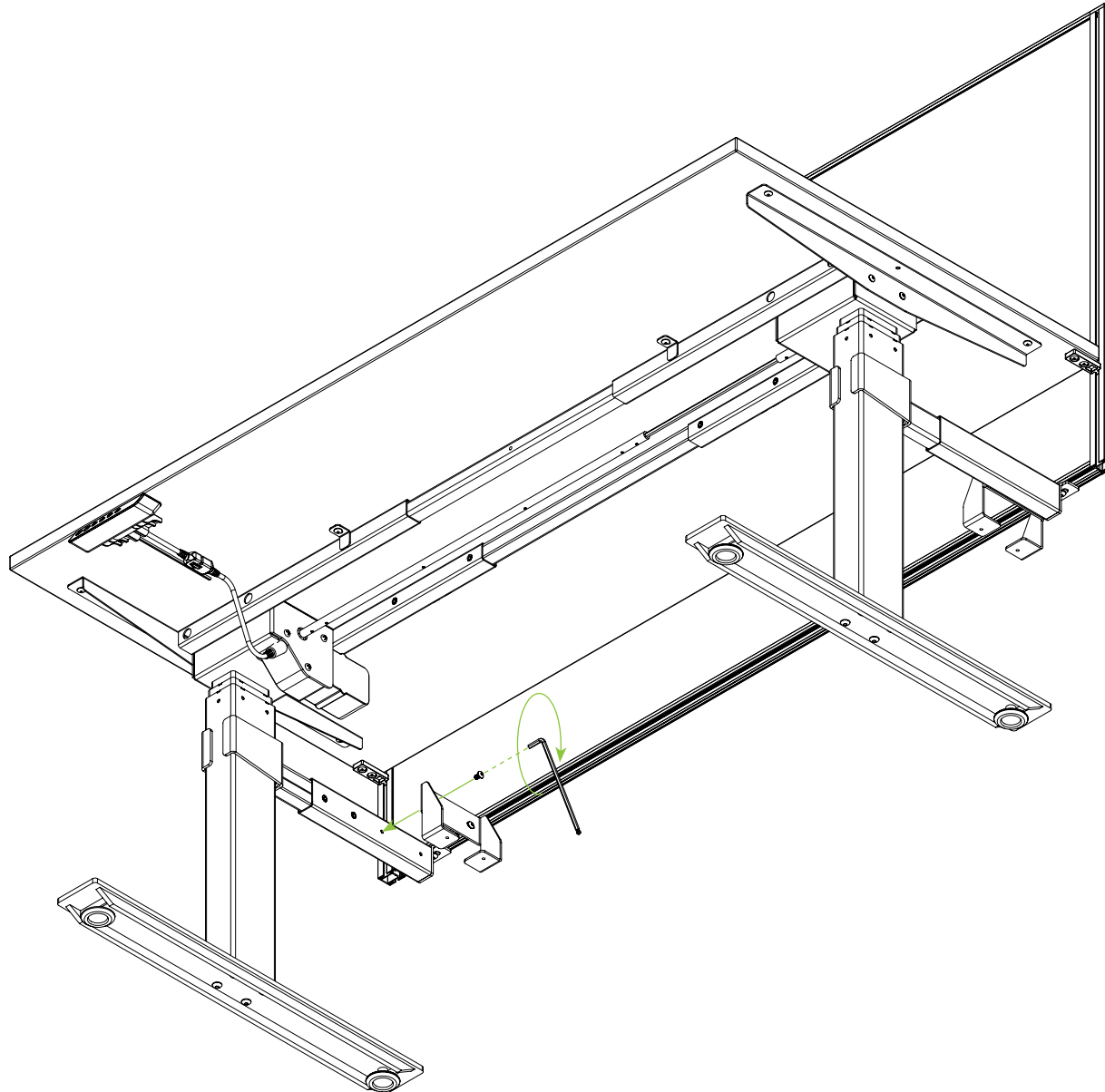

Optional Cable Tray

Installation Guide

Step 2



4 x M5x6

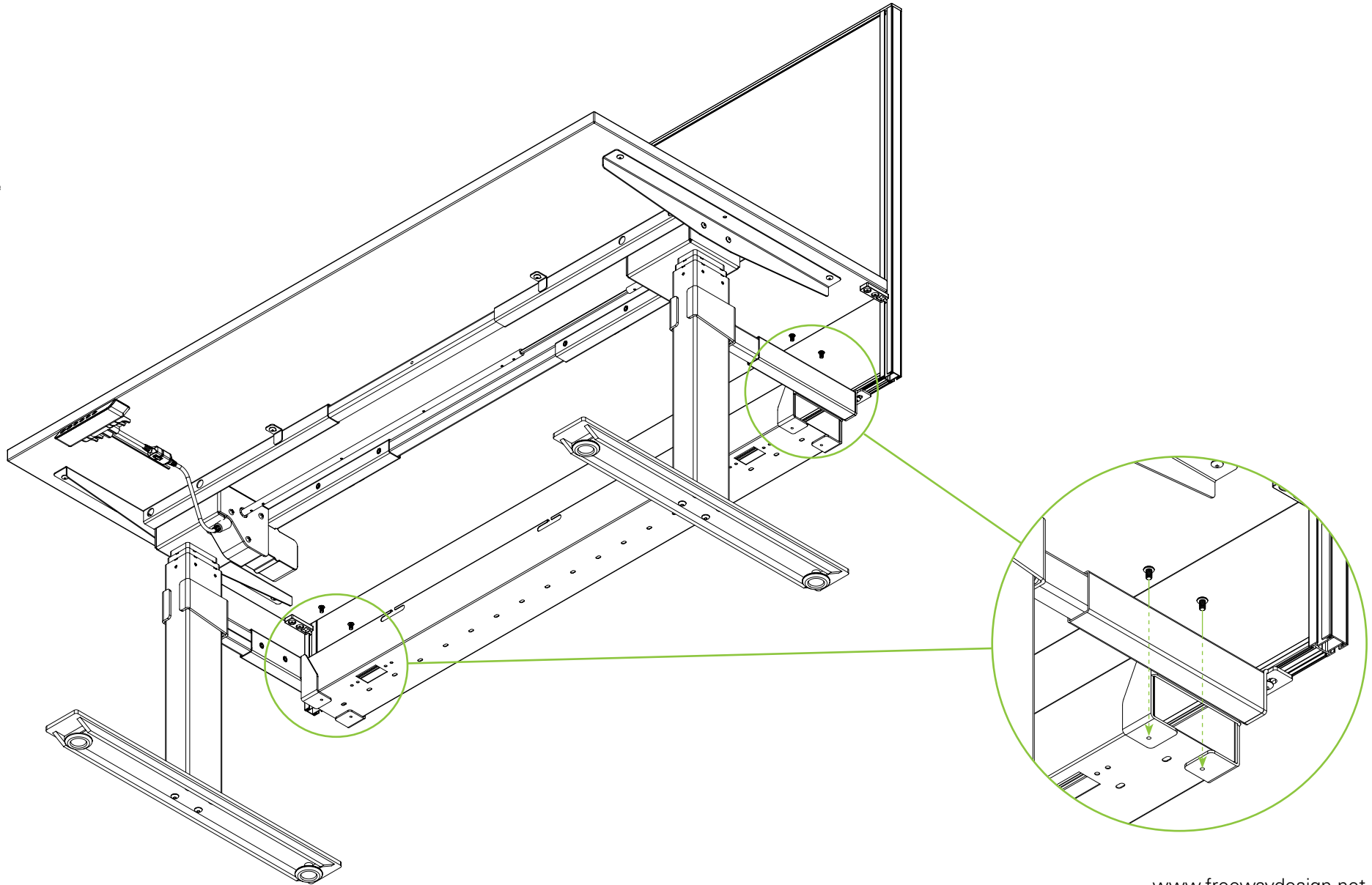

Directions For Use

IMPORTANT

Please carefully read the assembly manual and direction for use prior to instalment, use and maintenance of the table frame to gain a complete understanding of its contents. It provides you with important information about the safety, use, installation and maintenance of the table.

WARNING: FAILURE TO COMPLY WITH OR OBSERVE ALL ASSEMBLY, SAFETY AND OPERATION INSTRUCTIONS REGARDING THE USE OF THIS PRODUCT MAY RESULT IN SERIOUS BODILY INJURY.

SAFETY

- The table must be used in a safe manner. Inappropriate use may cause damage to the table and/or cause bodily harm to the user or persons nearby.
- Do not tamper with electrical components as this may lead to serious bodily harm.
- Only connect the electric table frames to the prescribed mains power voltage
- Do not use the table frame to lift people.
- Please retain this operation manual and pass it on to any future owner.

USAGE

- The height-adjustable table is designed for use in dry work environments only.
- The table height is infinitely adjustable within its height range so that it can be set to the user's most ergonomic working height. The user should seek professional help to establish their optimum working height.
- The table has been designed as a devise to elevate the users work surface and associated office peripherals. Do not use the table frame for any other purposes than that which it has been designed for. Any other use is at user's own risk!
- Do not crawl, lie or move around under the table frame, and do not sit or stand on the table frame.
- CHILDREN should only use the table when supervised by adults.
- Liability: The manufacturer accepts under no circumstances warranty claims or liability claims for damages arising from improper use or handling of the table frame other than that described in this operation manual.

SET UP AND INSTALLATION

Assemble the table frame according to the assembly instructions on pages 4 - 12.

- Place the table in a safe distance from window frames, radiators, furniture etc. so that persons cannot become trapped.
- Level the table with the adjustable feet ensuring that the table is stable.
- Check that no cables can get jammed.
- Connect the table to the 110 or 230 VAC power outlet.

The table is now ready for use.

Directions For Use

MAINTENANCE AND DEFECTS

- The table does not require any maintenance by usage as described in chapter 2 in the directions for use.
- The table is only to be maintained with a wrung cloth.
- In the event of the occurrence of jarring sounds during operation, STOP using the table and please contact the dealer.

TECHNICAL DATA

Height Range: 610-1230mm including worktop

Speed: ~30mm/s

Input Voltage: 100-240V AC 50-60Hz

Output Voltage: 24V DC 2.0A

Duty Cycle: 10% 2min on 18min off

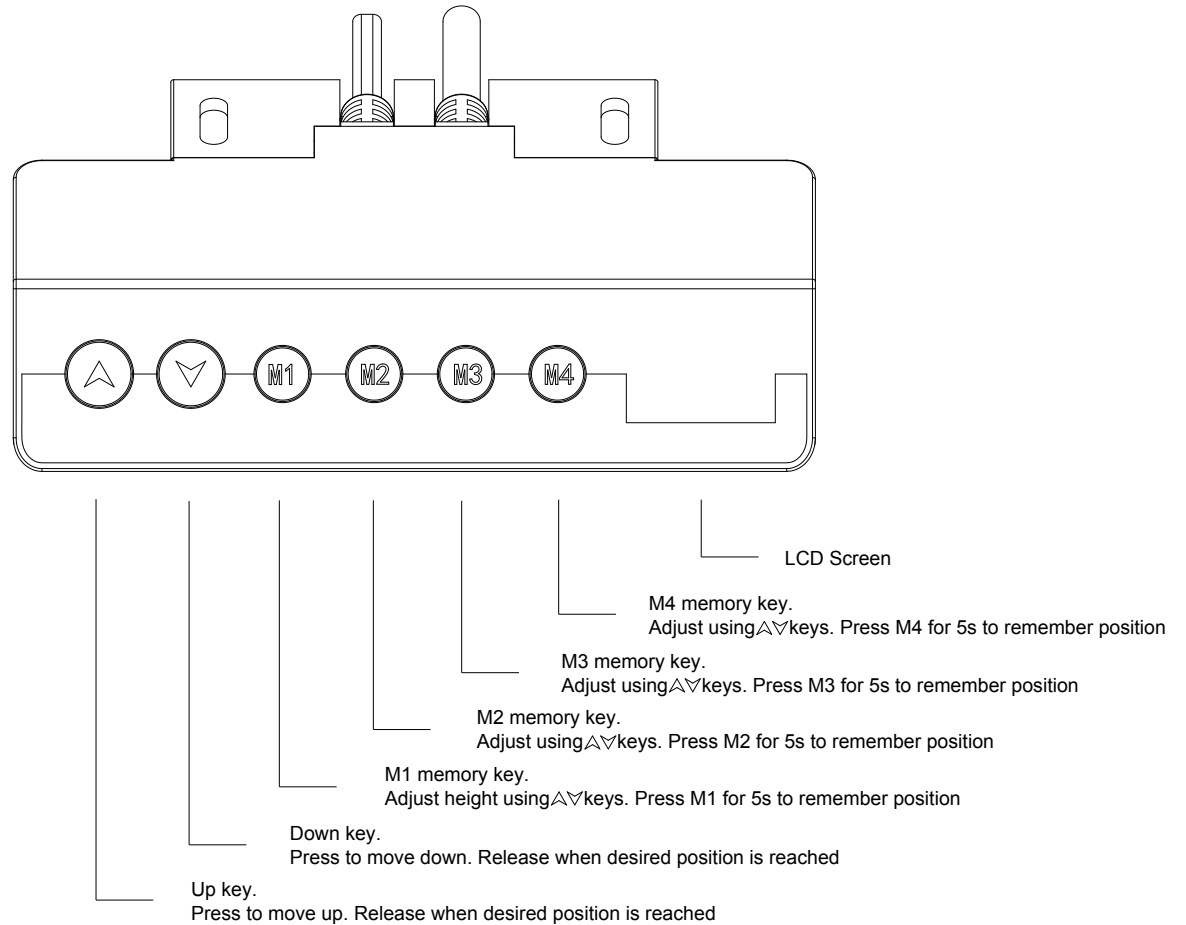



freeway

Agile

Installation Guide - Electric 2 Column Left Hand Return For Single & Double Desk

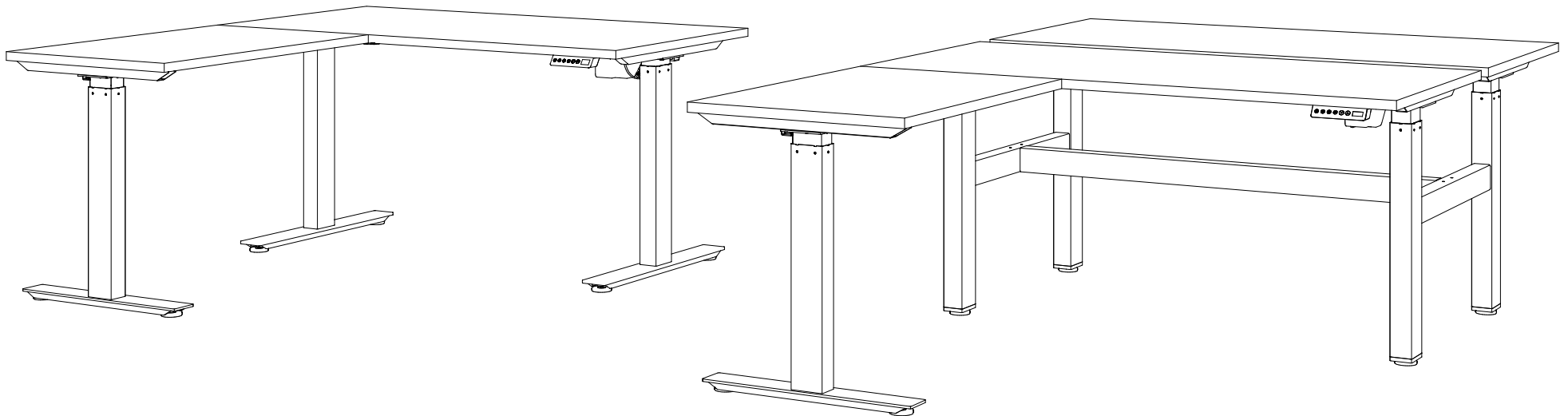

Parts:

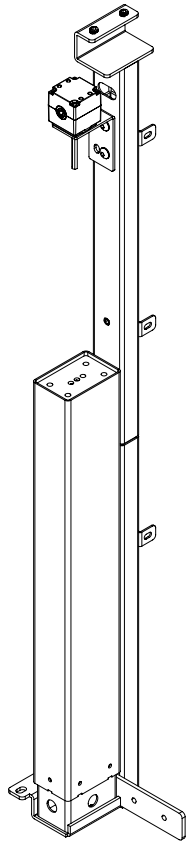

1 x Return Leg

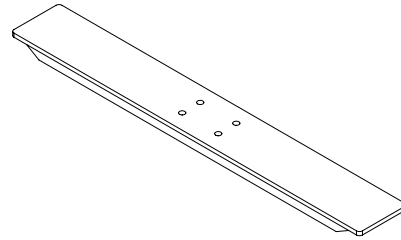

1 x Foot

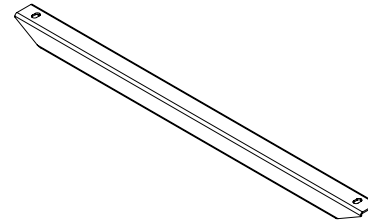

1 x Support Bar

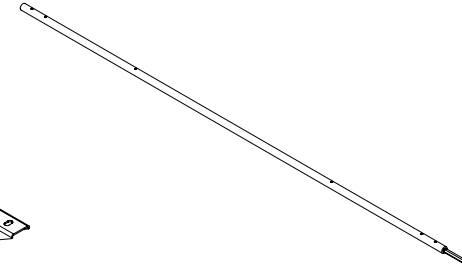

1 x Drive Bar

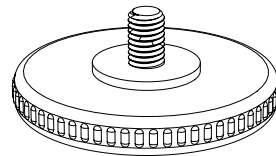

2 x Levelling Foot



4 x M8x25



5 x ST5x23



4 x M8x10

Step 1



2 x M8x10

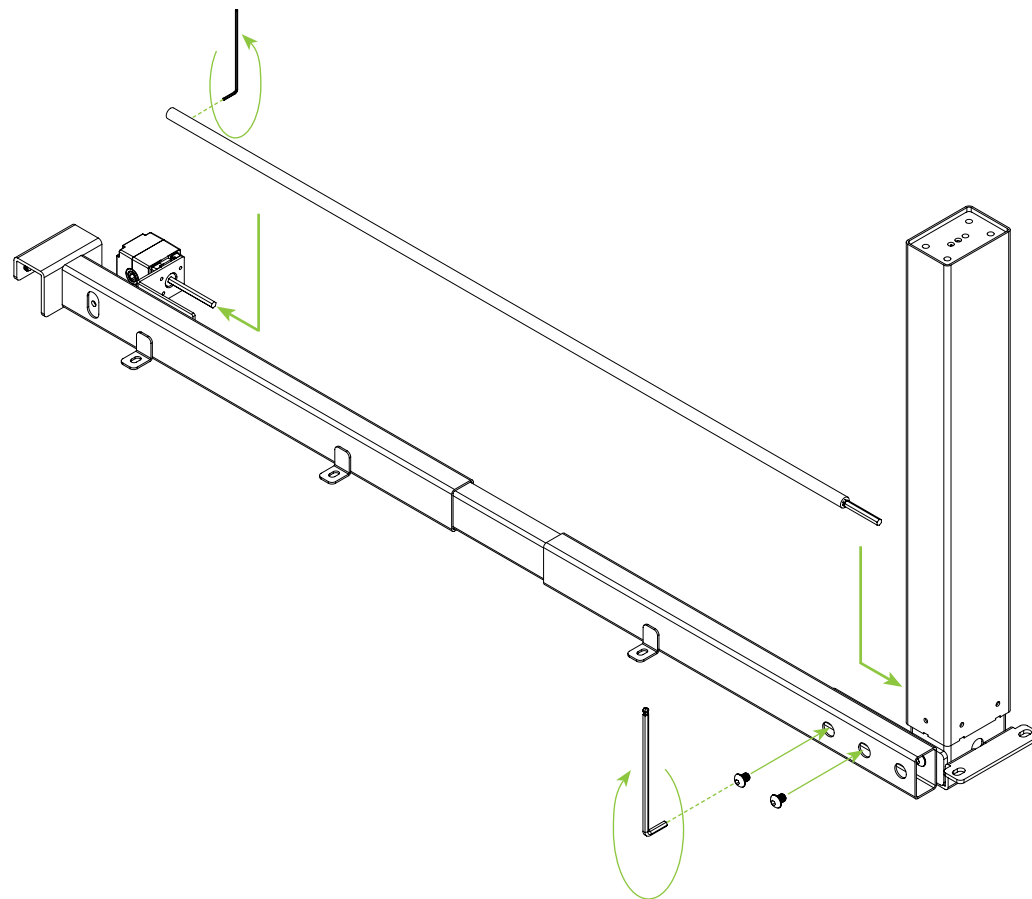

Step 2



2 x M8x10

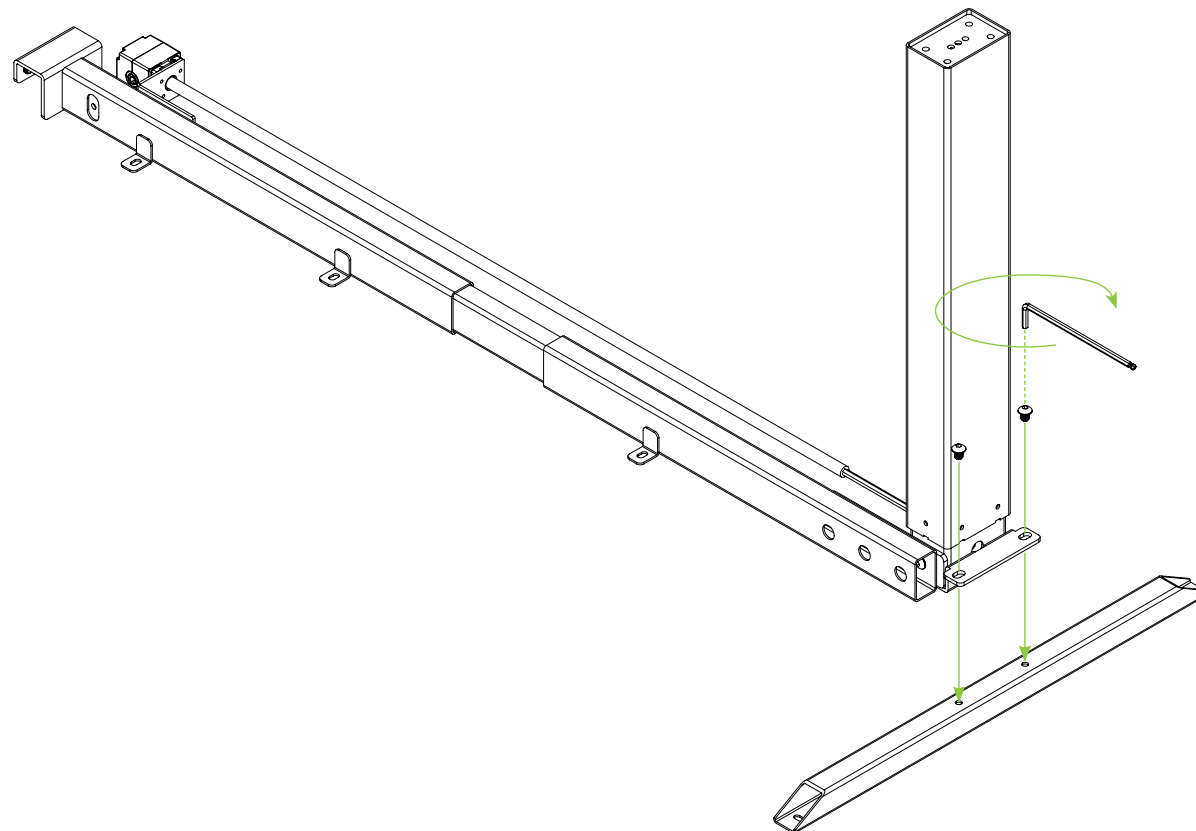

Step 3

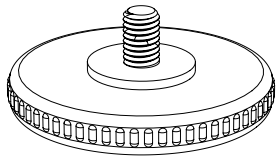

2 x Levelling Foot

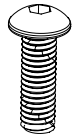

4 x M8x25

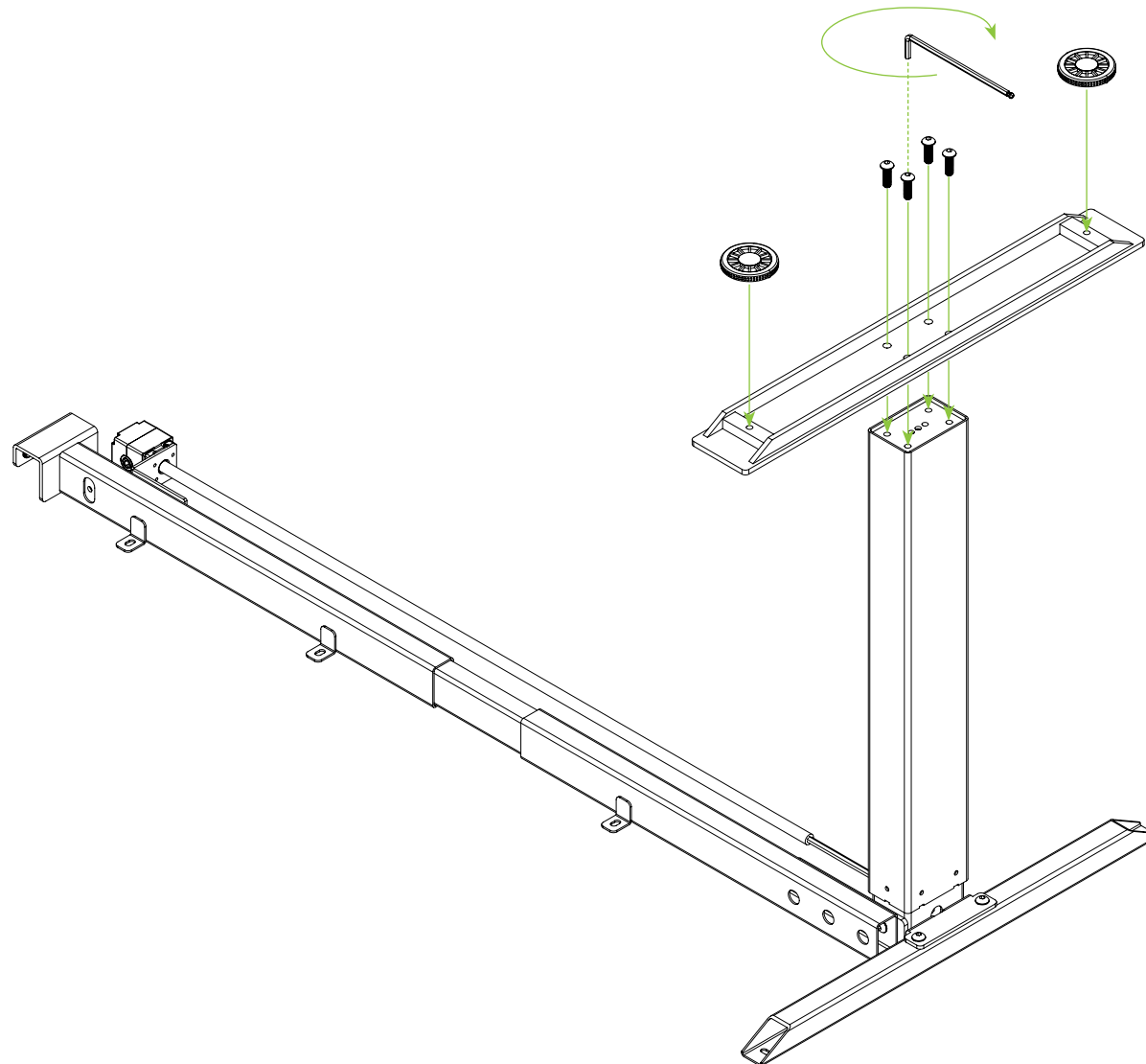



Option 1 - Electric 2 Column Left Hand Return for Single Desk

Go to page 7

Option 2 - Electric 2 Column Left Hand Return for Double Desk

Go to page 11

Option 1: Single Desk and Return Step 4

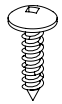

6 x ST5x23

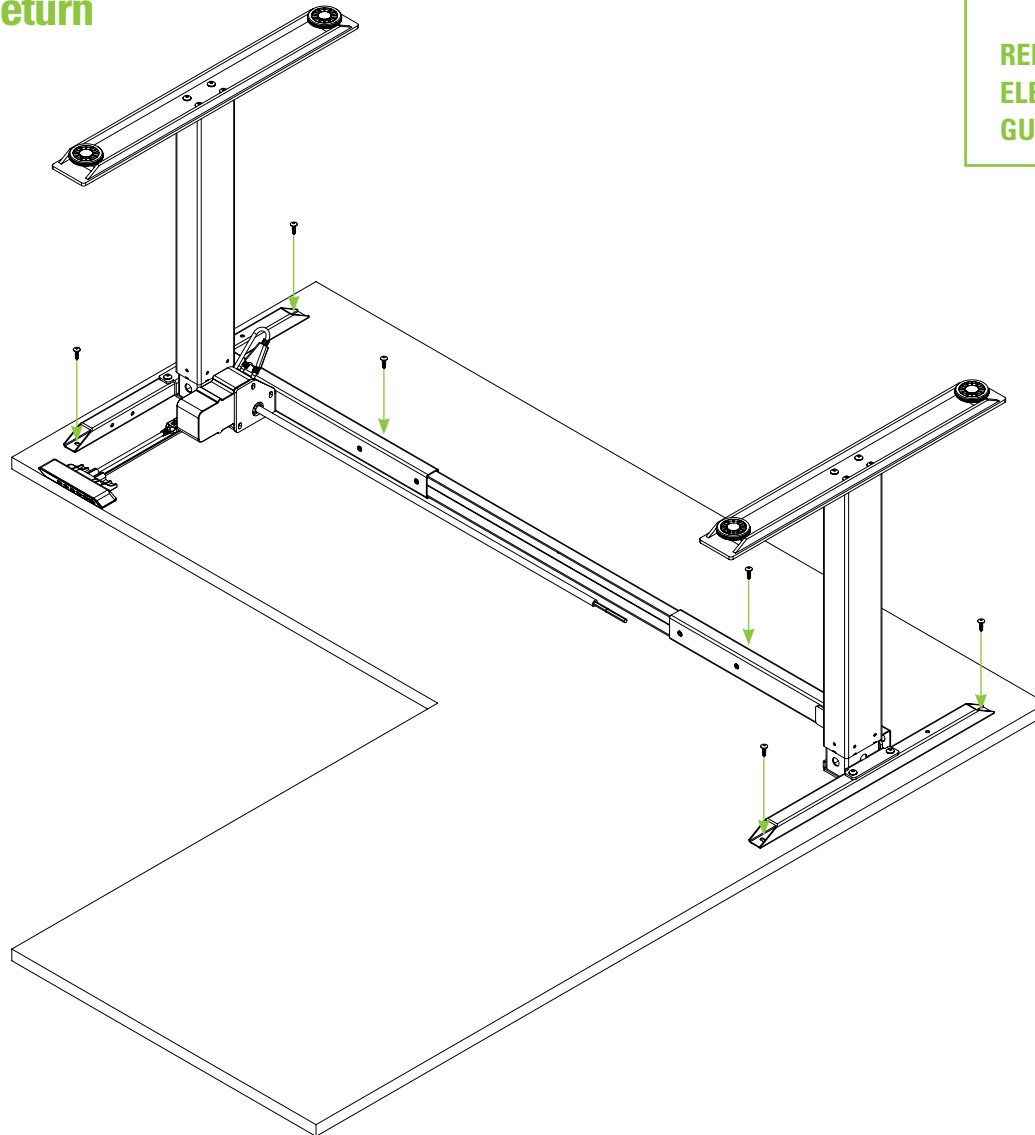

IMPORTANT!

REFER TO SETPS 1-4 OF SINGLE-SIDED
ELECTRIC 2 COLUMN DESK INSTALLATION
GUIDE TO ASSEMBLE DESK FRAME.

Step 5

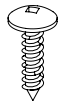

5 x ST5x23

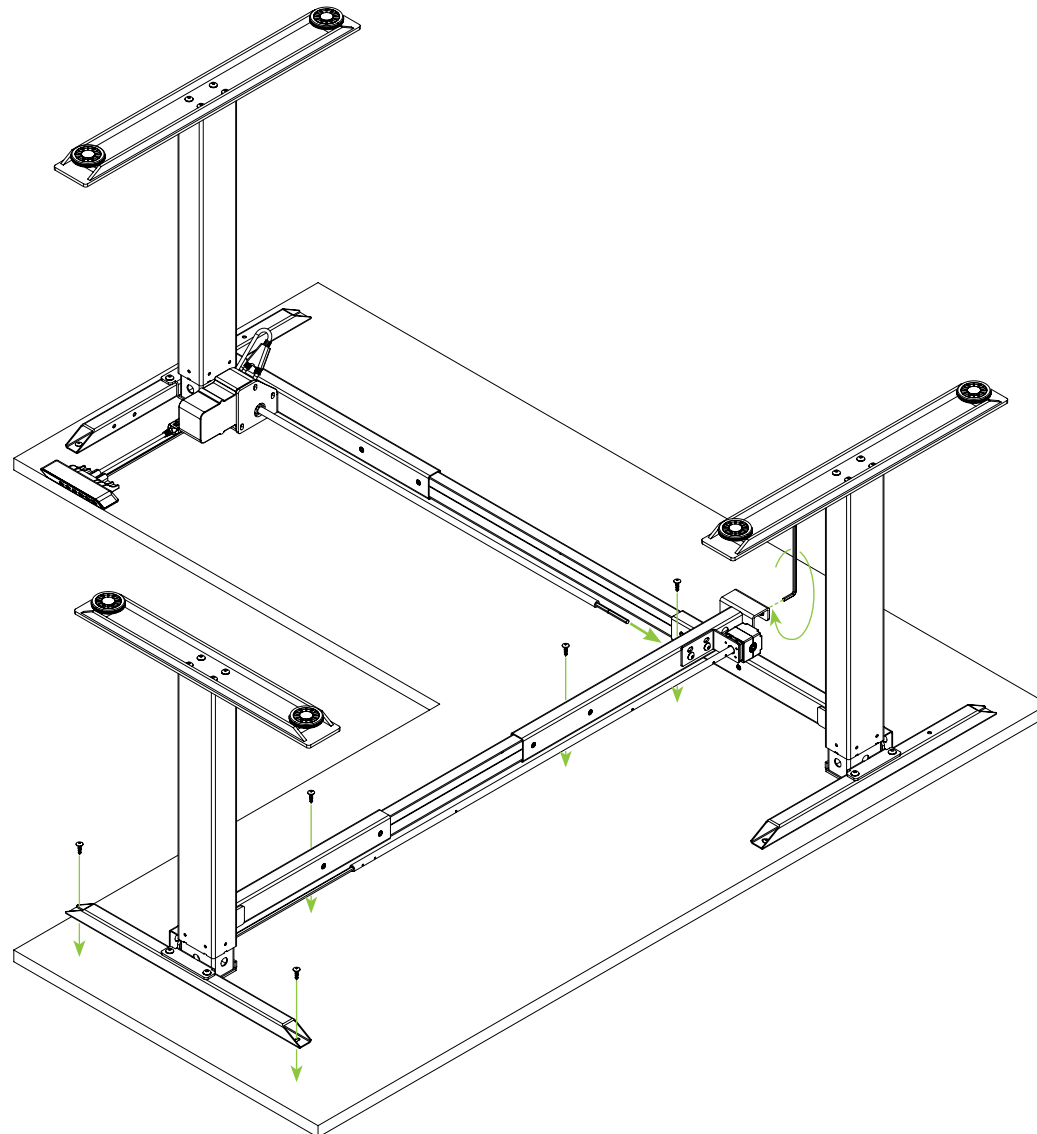

Step 6

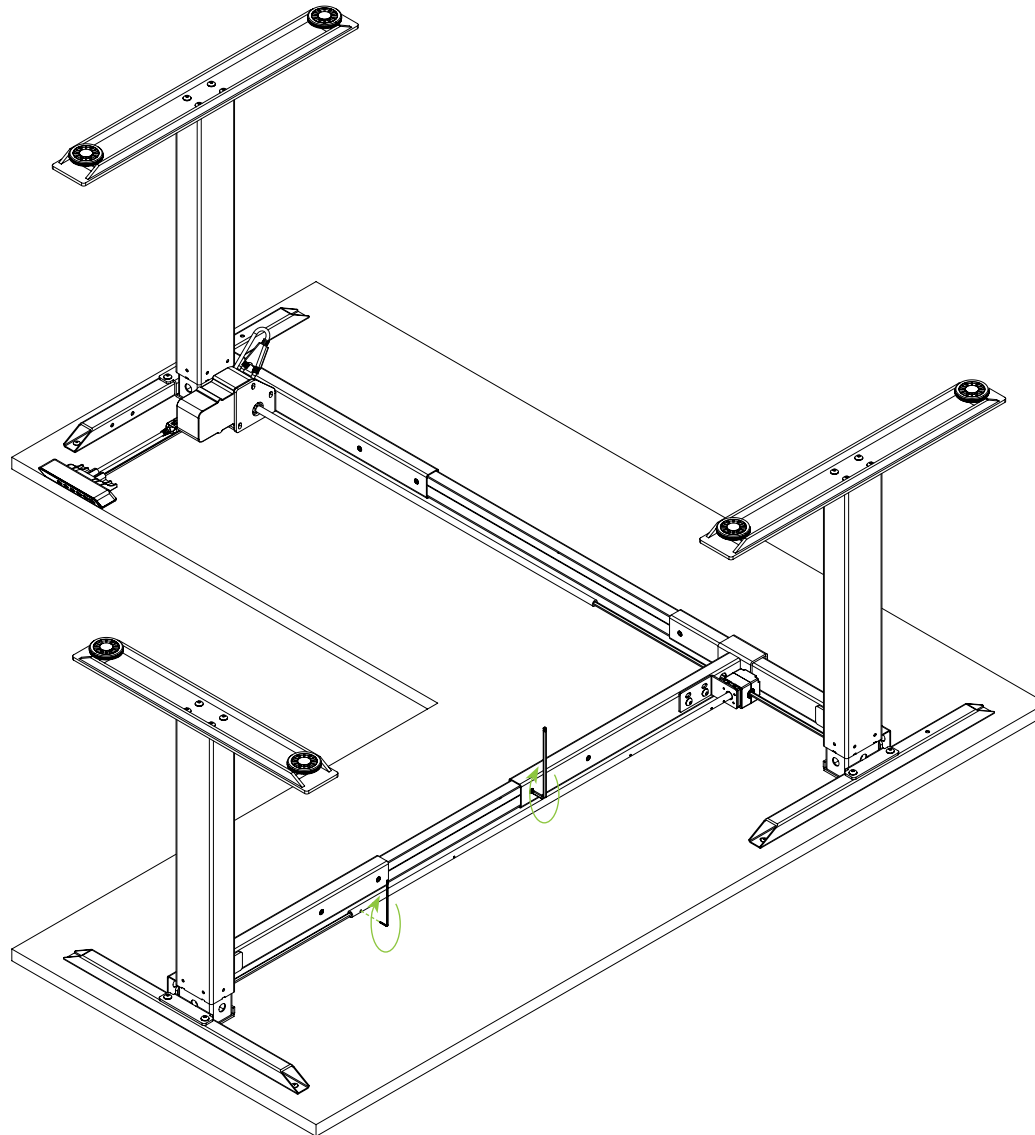

Completed

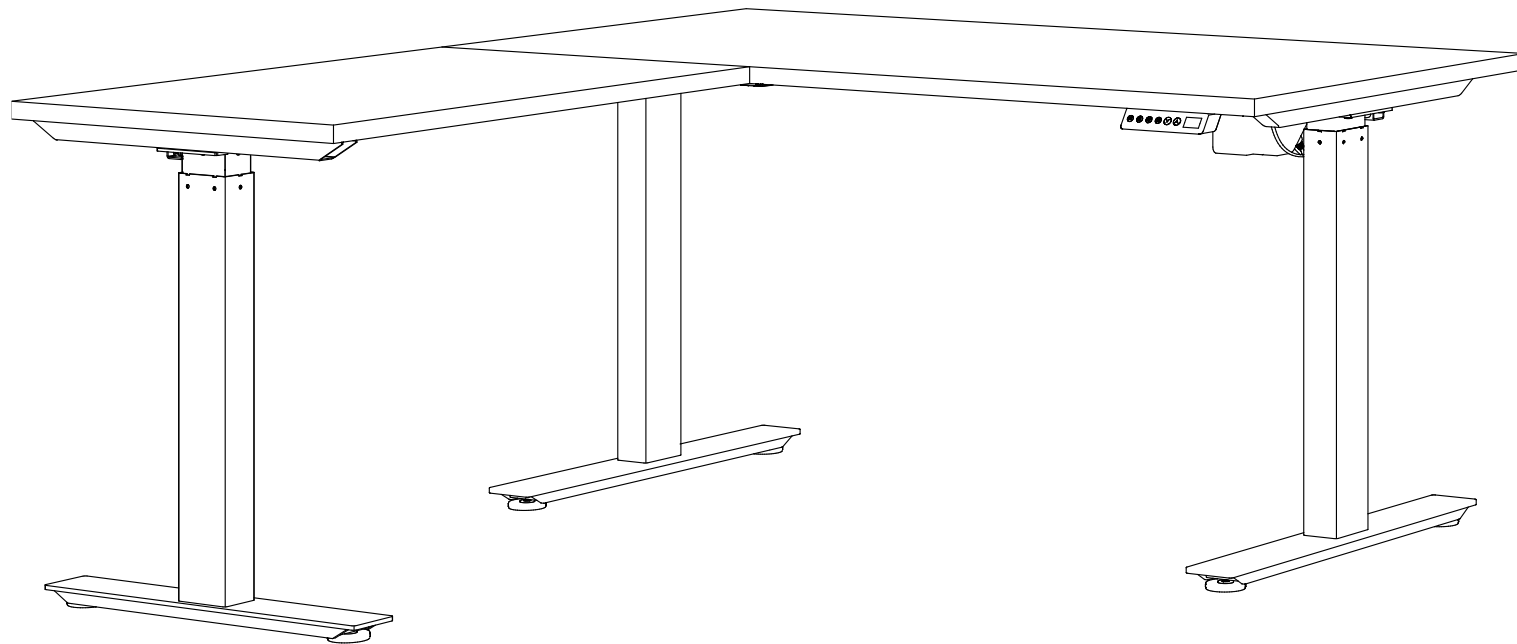

Option 2: Double Desk and Return Step 4

IMPORTANT!
REFER TO SETPS 1-8 OF DOUBLE-SIDED
ELECTRIC 2 COLUMN DESK INSTALLATION
GUIDE TO ASSEMBLE DESK FRAME.

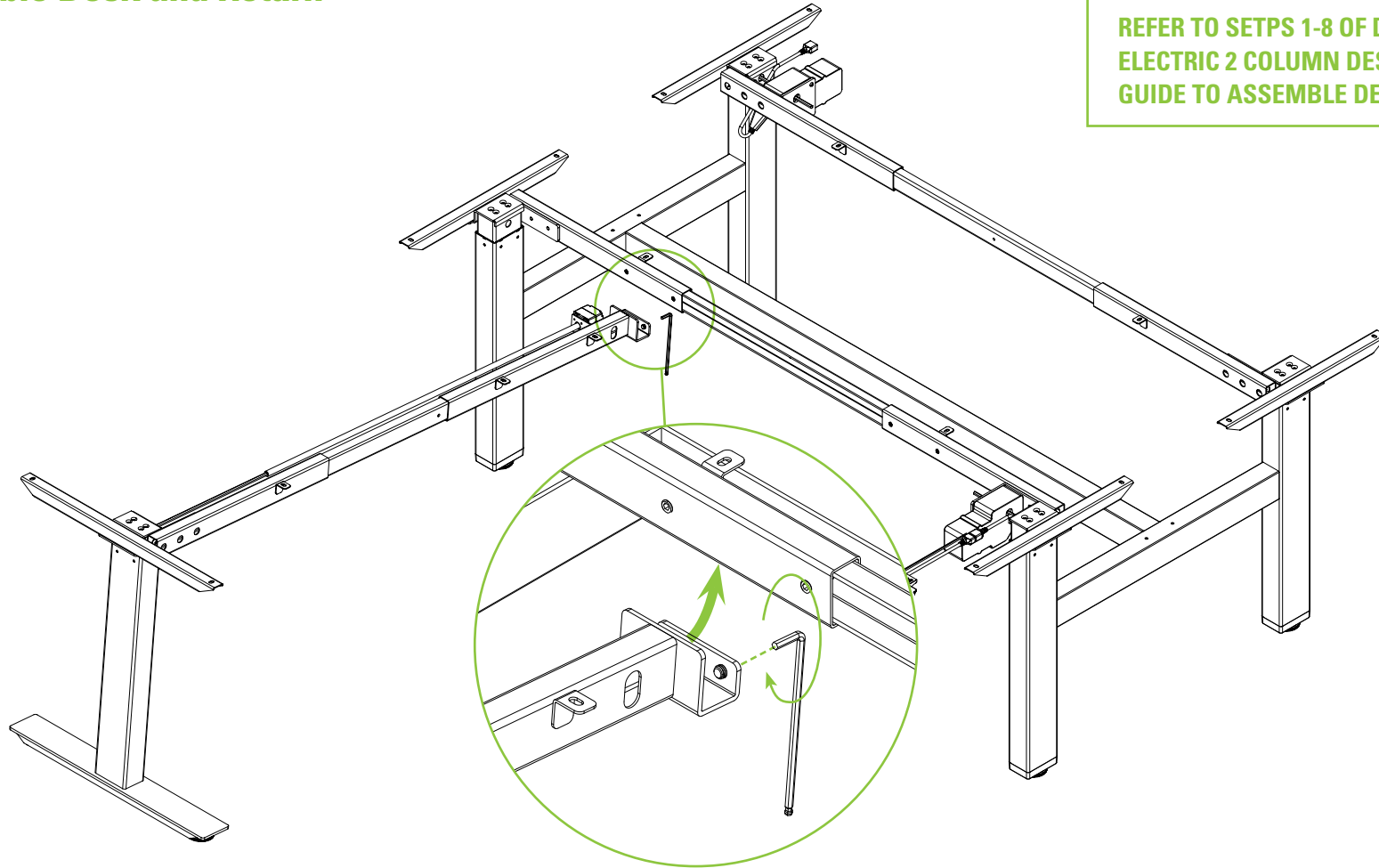

Step 5

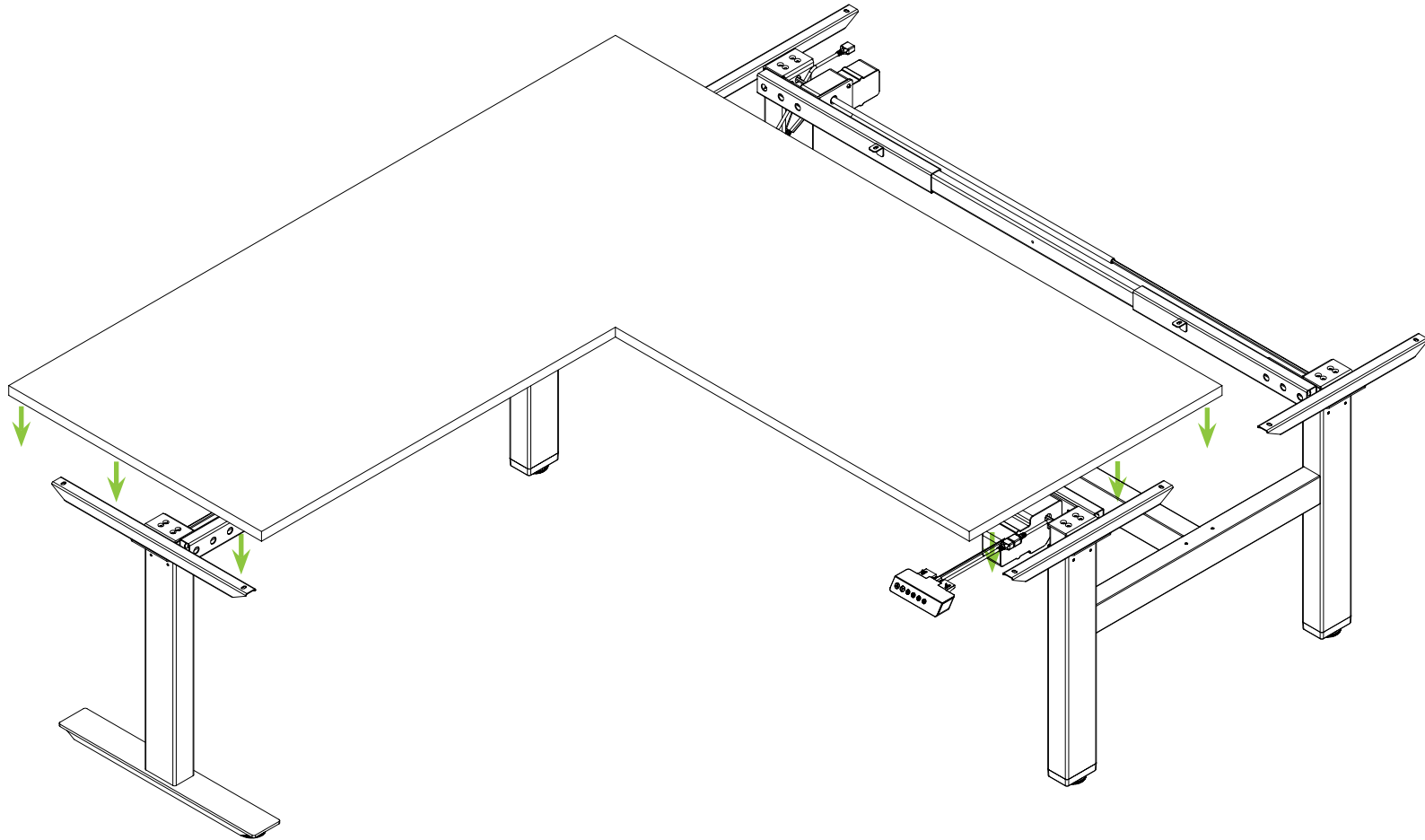

Step 6

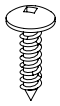

11 x ST5x23

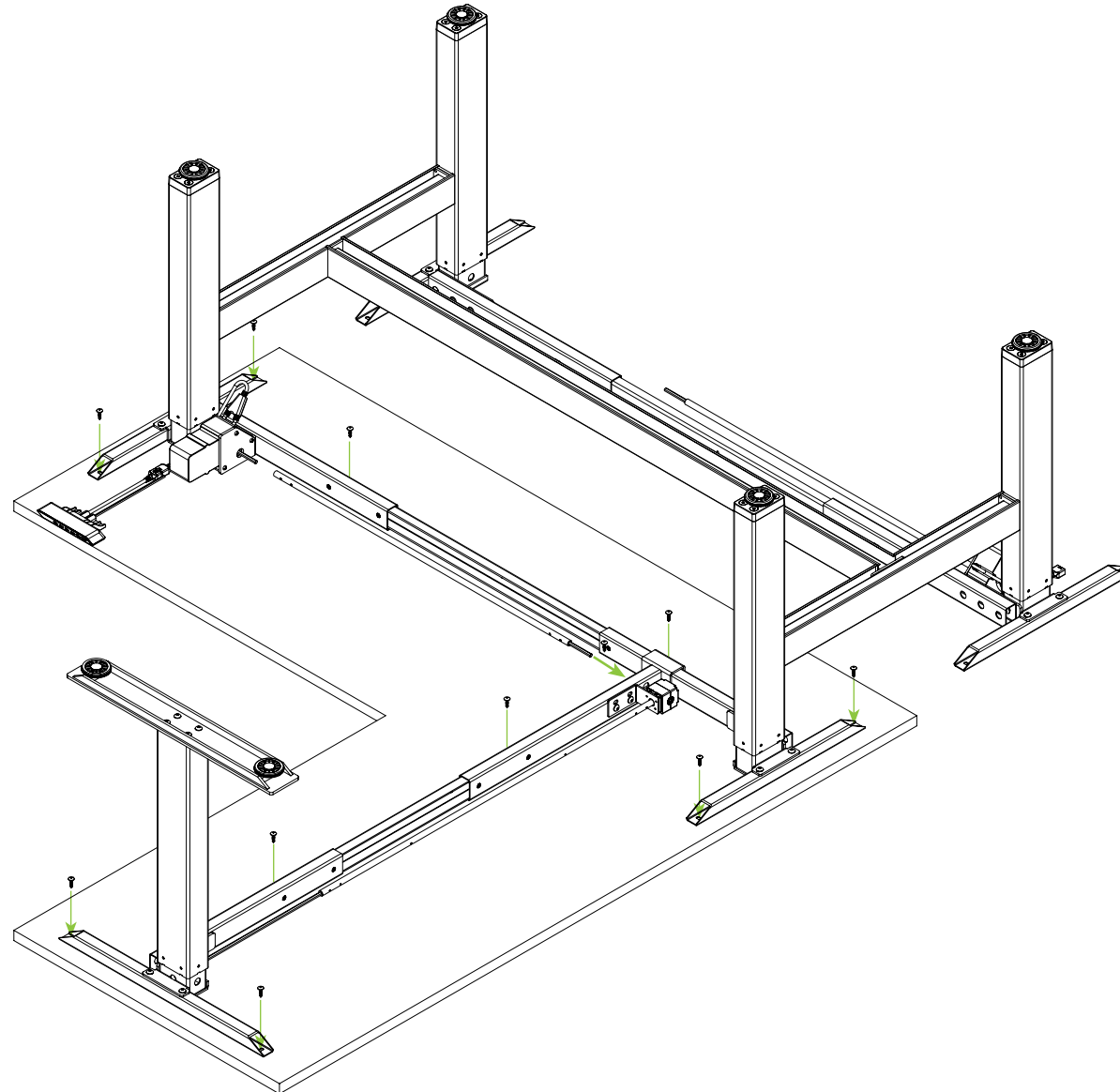

Step 7

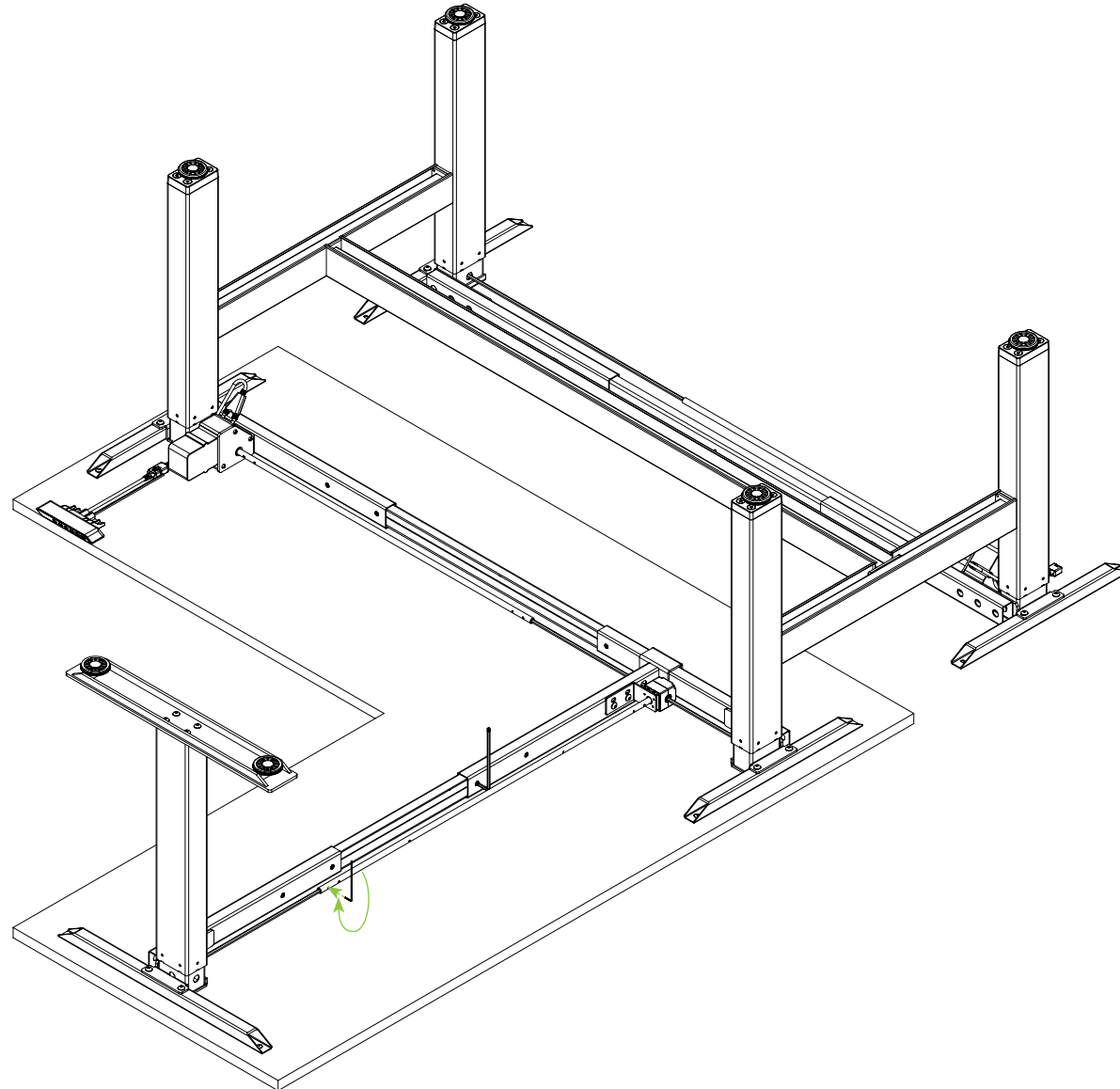

Completed

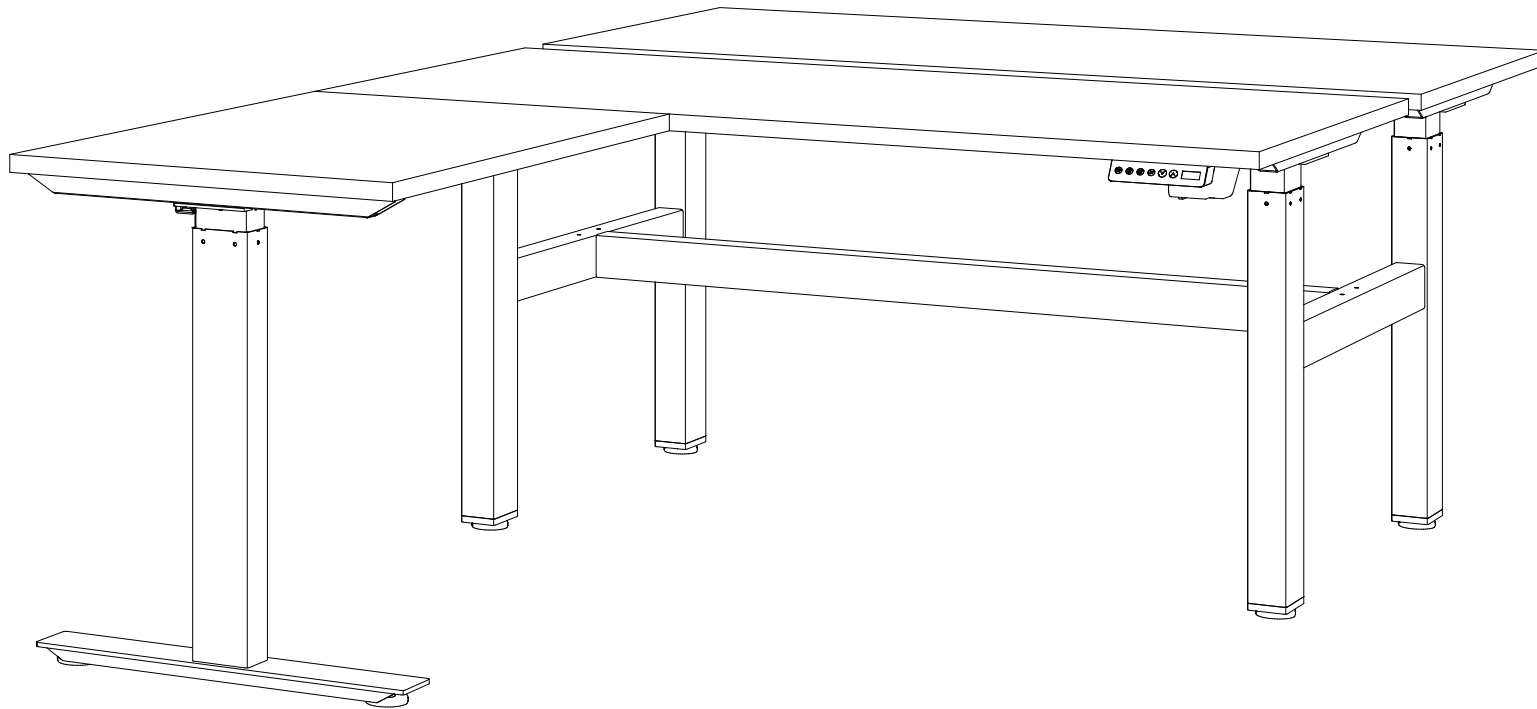



freeway

Agile

Installation Guide - Electric 2 Column Right Hand Return For Single & Double Desk

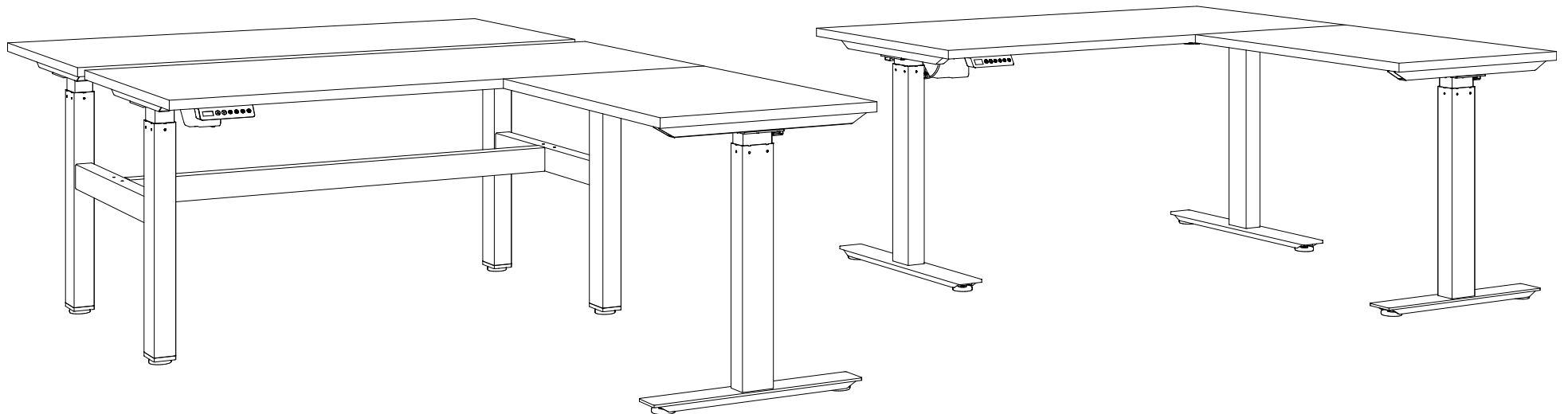

Parts:

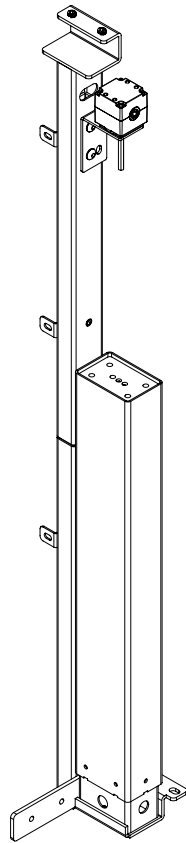

1 x Return Leg

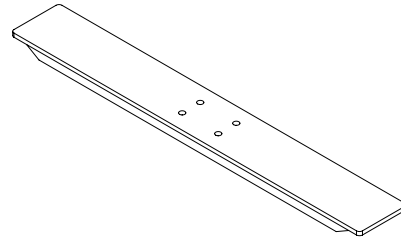

1 x Foot

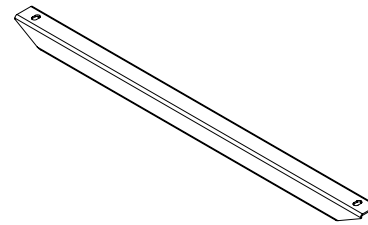

1 x Support Bar

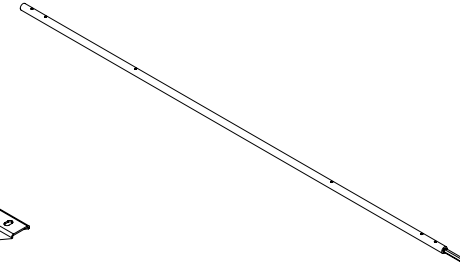

1 x Drive Bar

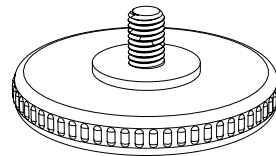

2 x Levelling Foot

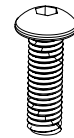

4 x M8x25



5 x ST5x23



4 x M8x10

Step 1



2 x M8x10

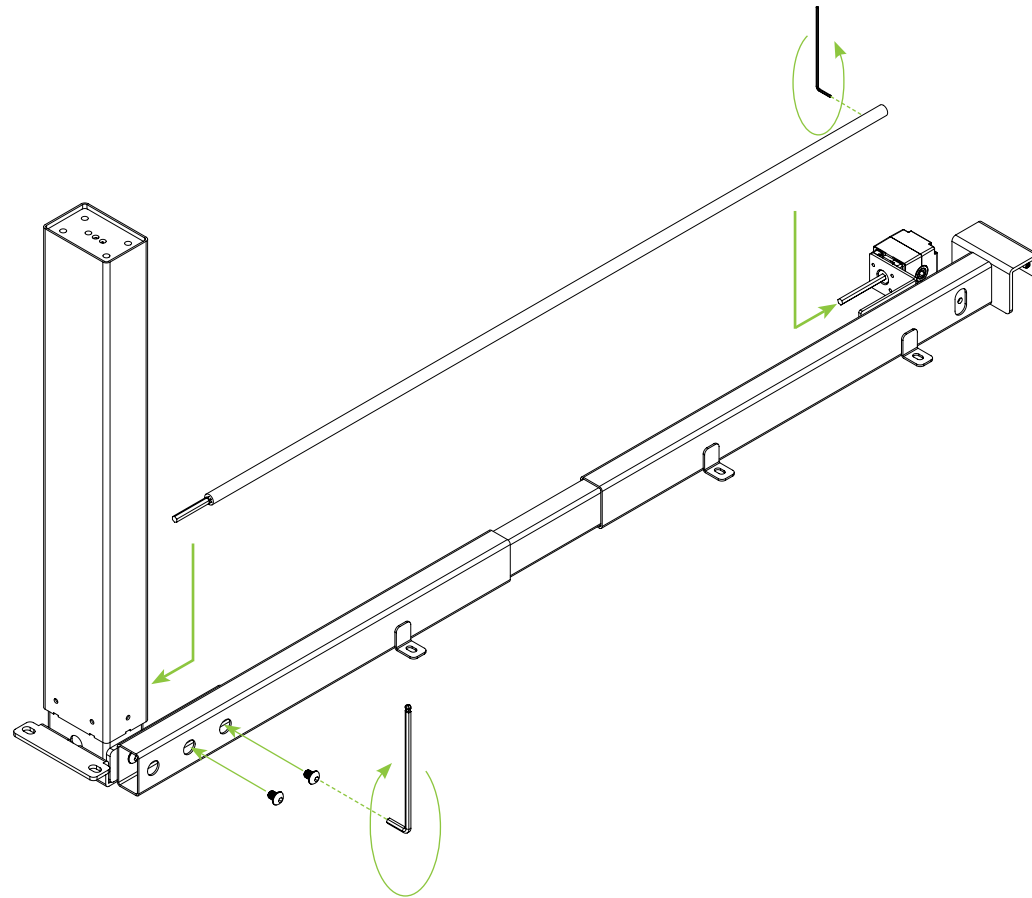

Step 2



2 x M8x10

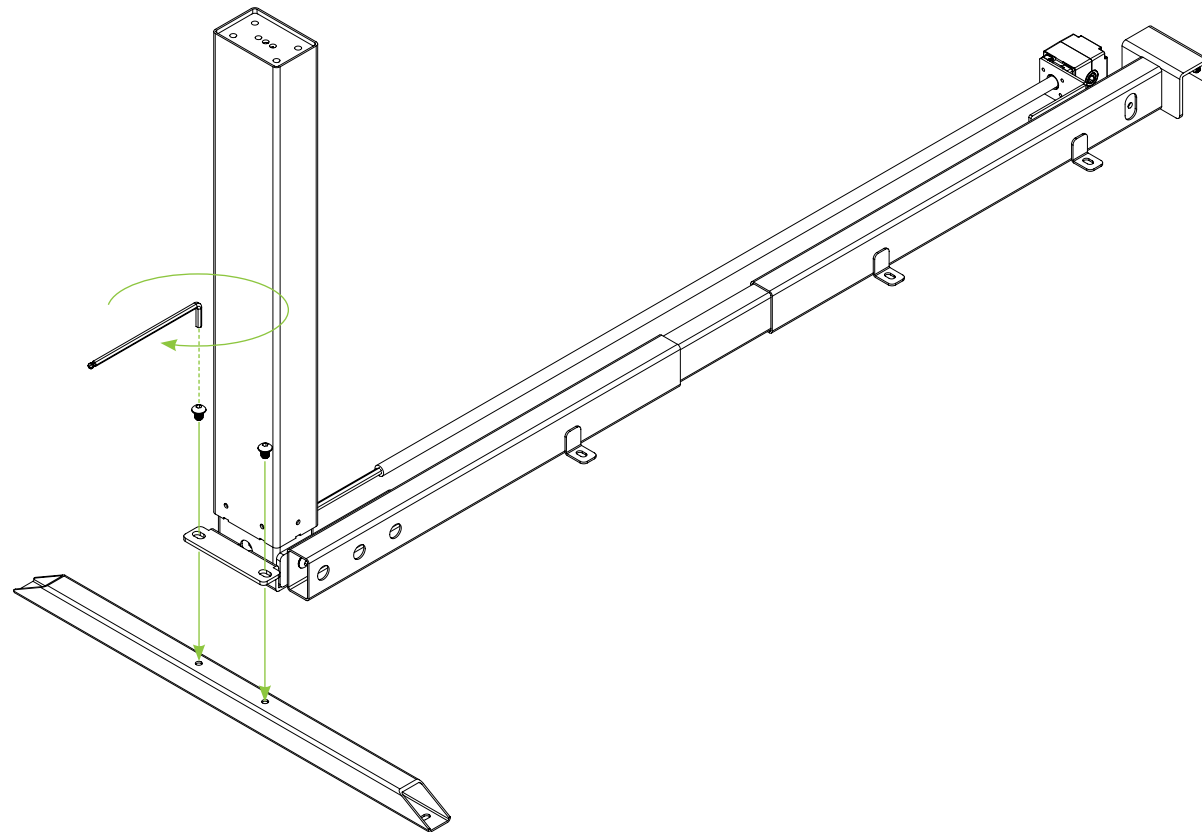

Step 3

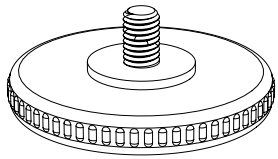

2 x Levelling Foot

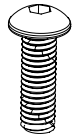

4 x M8x25

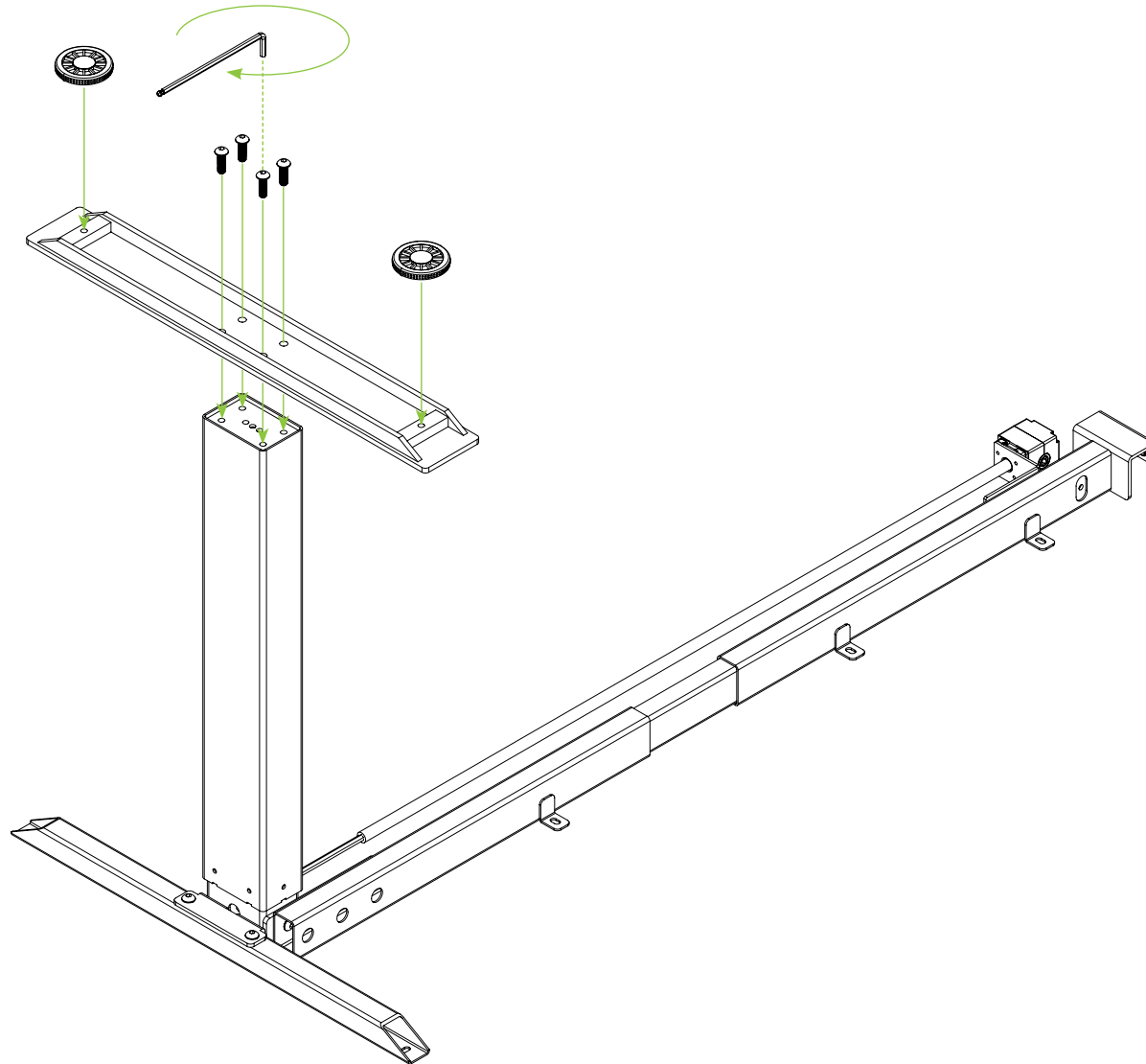

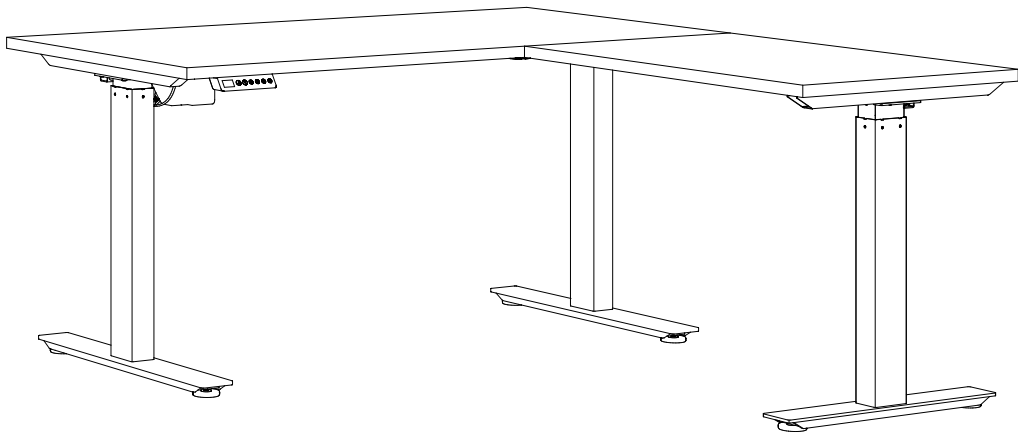

Option 1 - Electric 2 Column Right Hand Return for Single Desk

Go to page 7

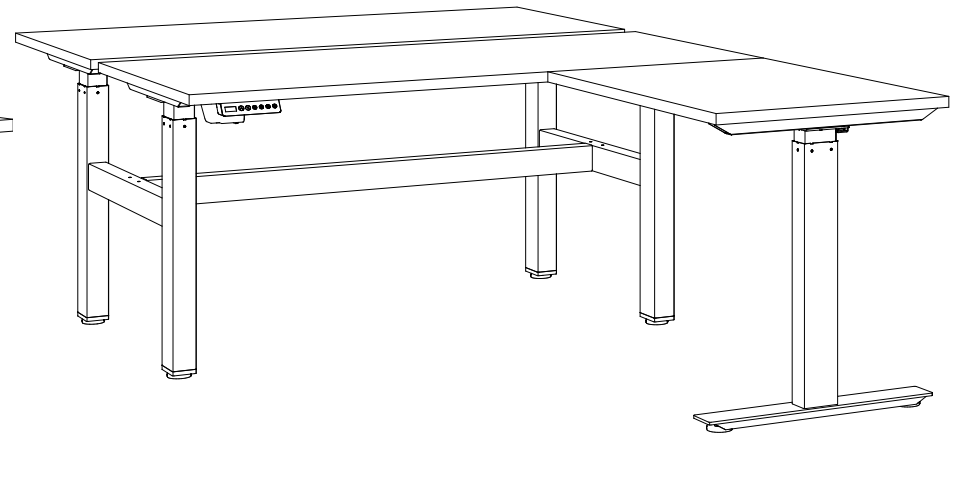

Option 2 - Electric 2 Column Right Hand Return for Double Desk

Go to page 11

Option 1: Single Desk and Return Step 4

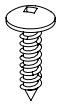

6 x ST5x23

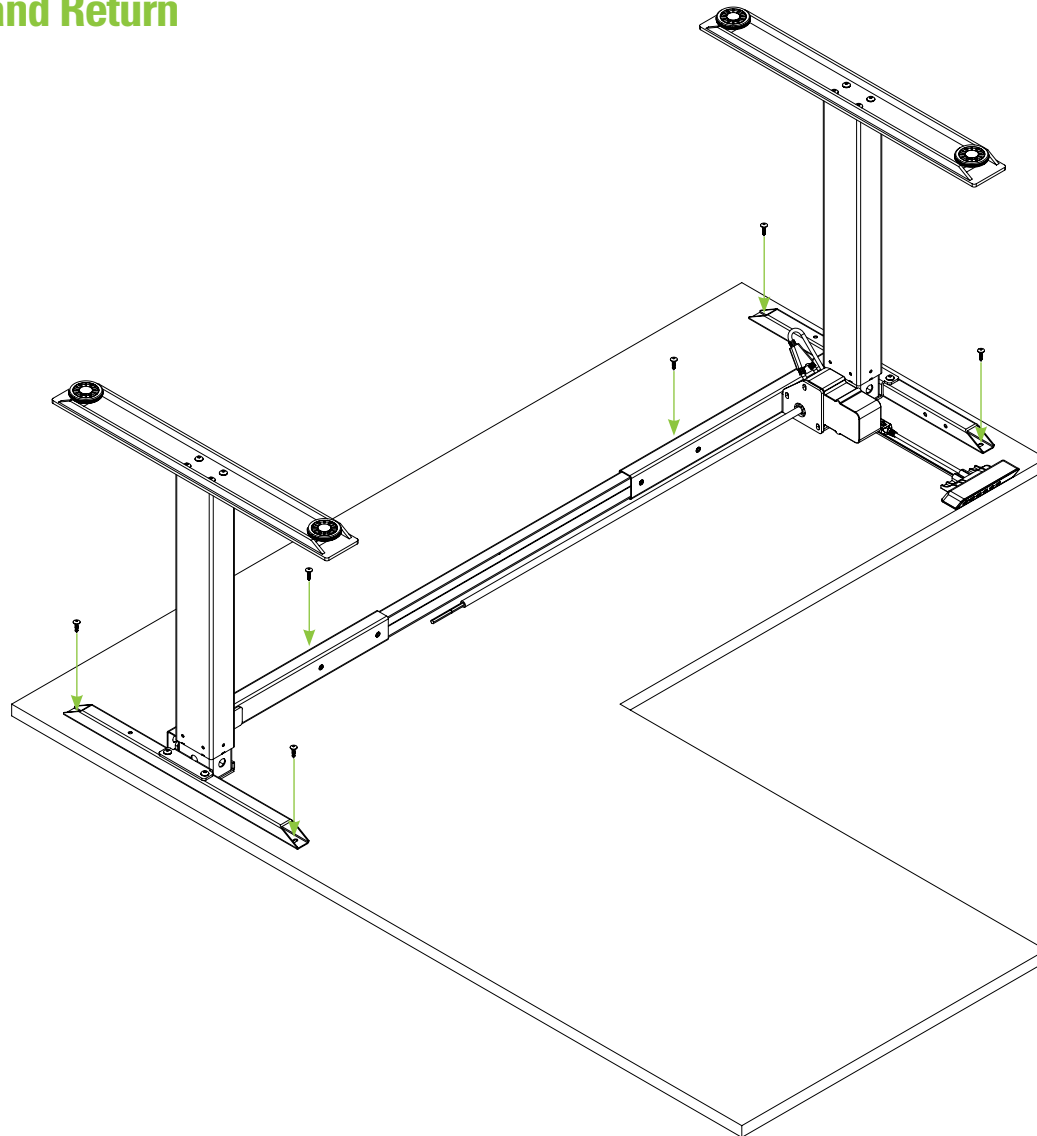

IMPORTANT!

REFER TO SETPS 1-4 OF SINGLE-SIDED
ELECTRIC 2 COLUMN DESK INSTALLATION
GUIDE TO ASSEMBLE DESK FRAME.

Step 5

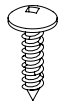

5 x ST5x23

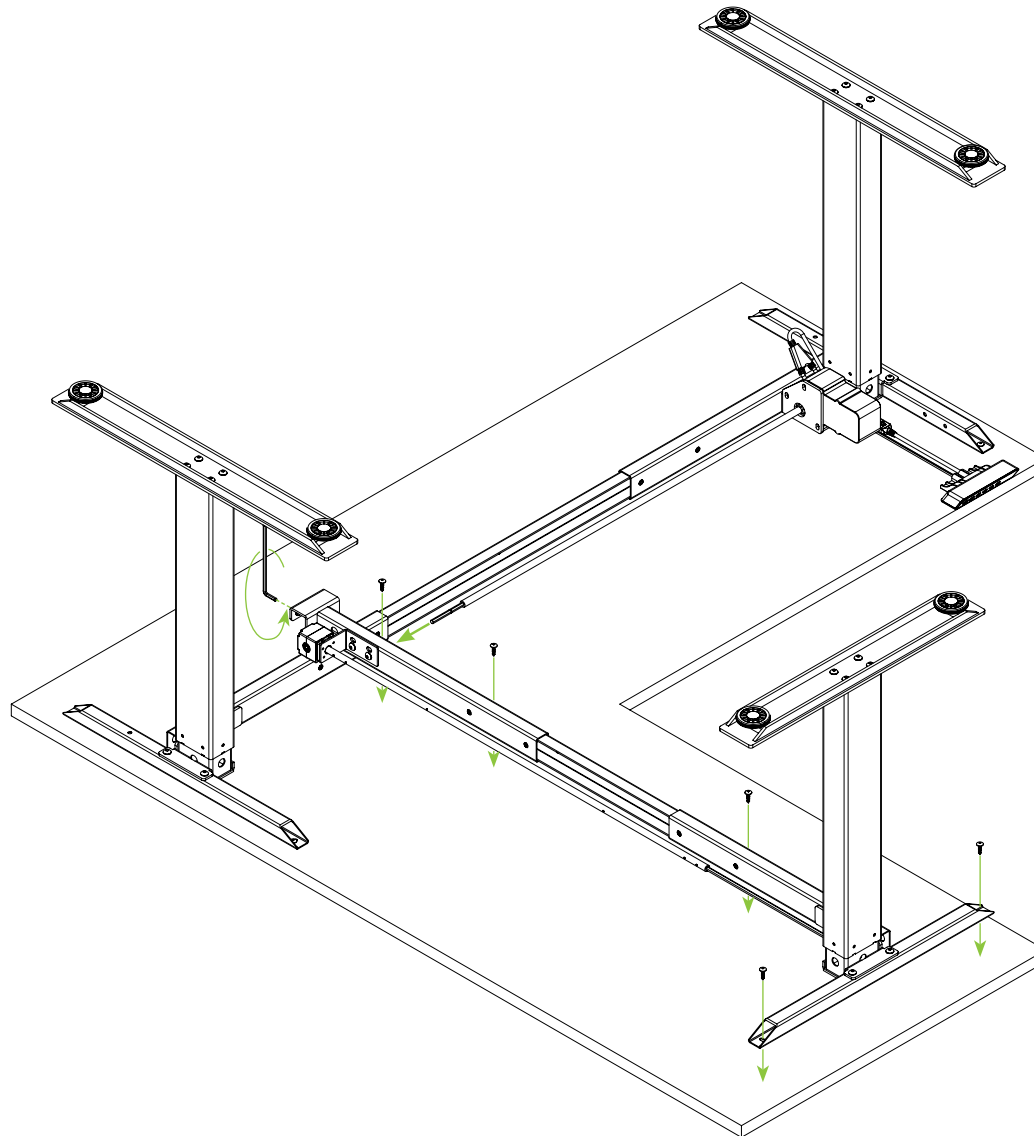

Step 6

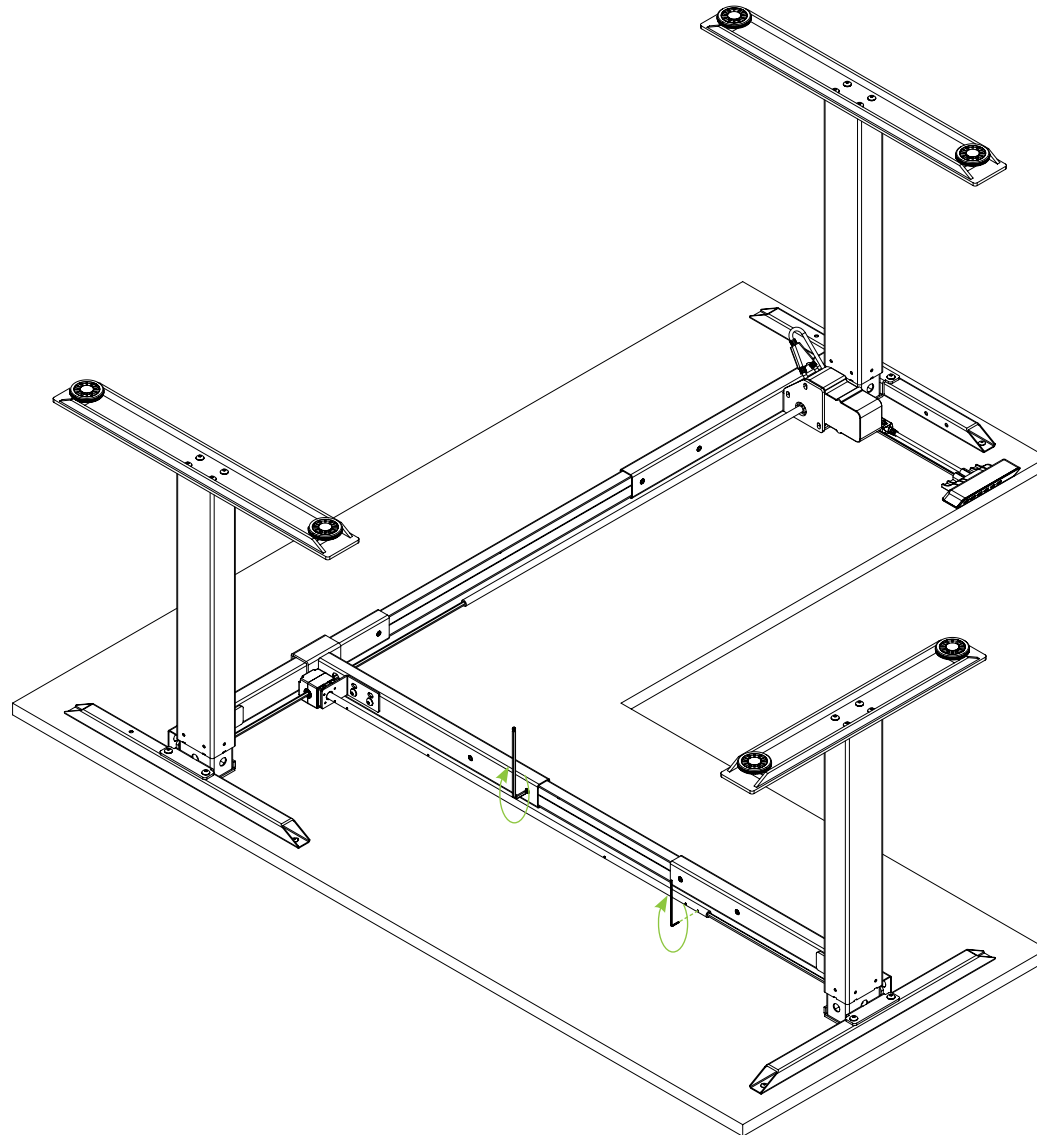

Completed

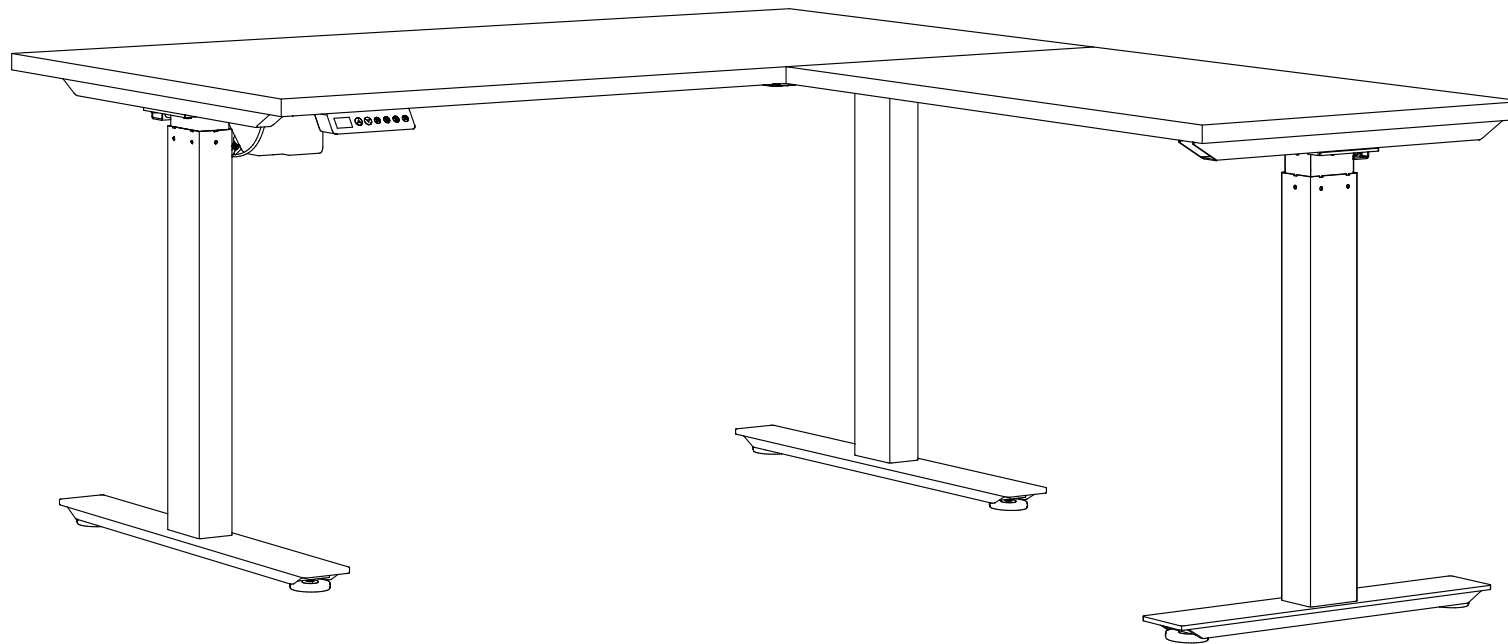

Option 2: Double Desk and Return Step 4

IMPORTANT!
REFER TO SETPS 1-8 OF DOUBLE-SIDED
ELECTRIC 2 COLUMN DESK INSTALLATION
GUIDE TO ASSEMBLE DESK FRAME.

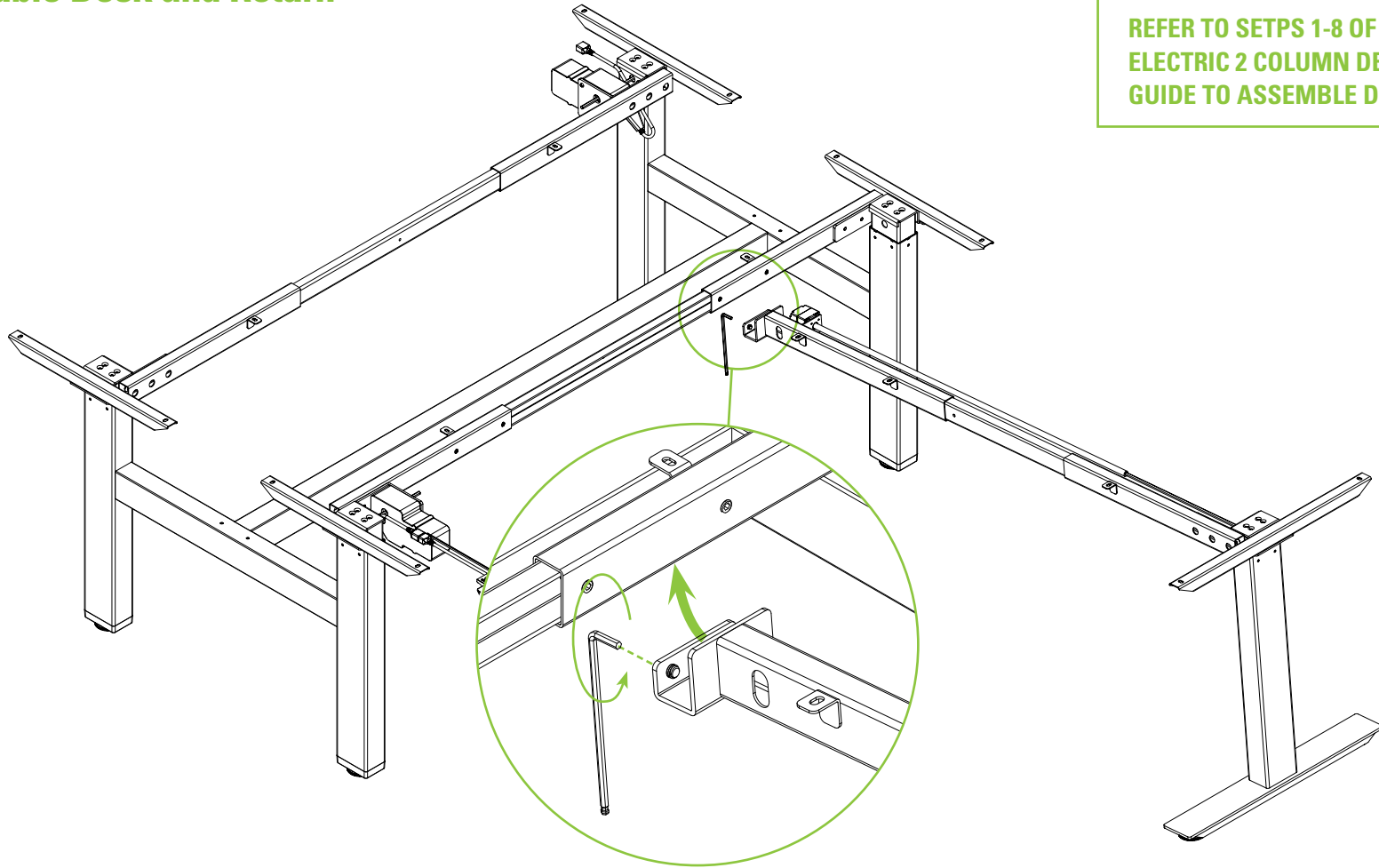

Step 5

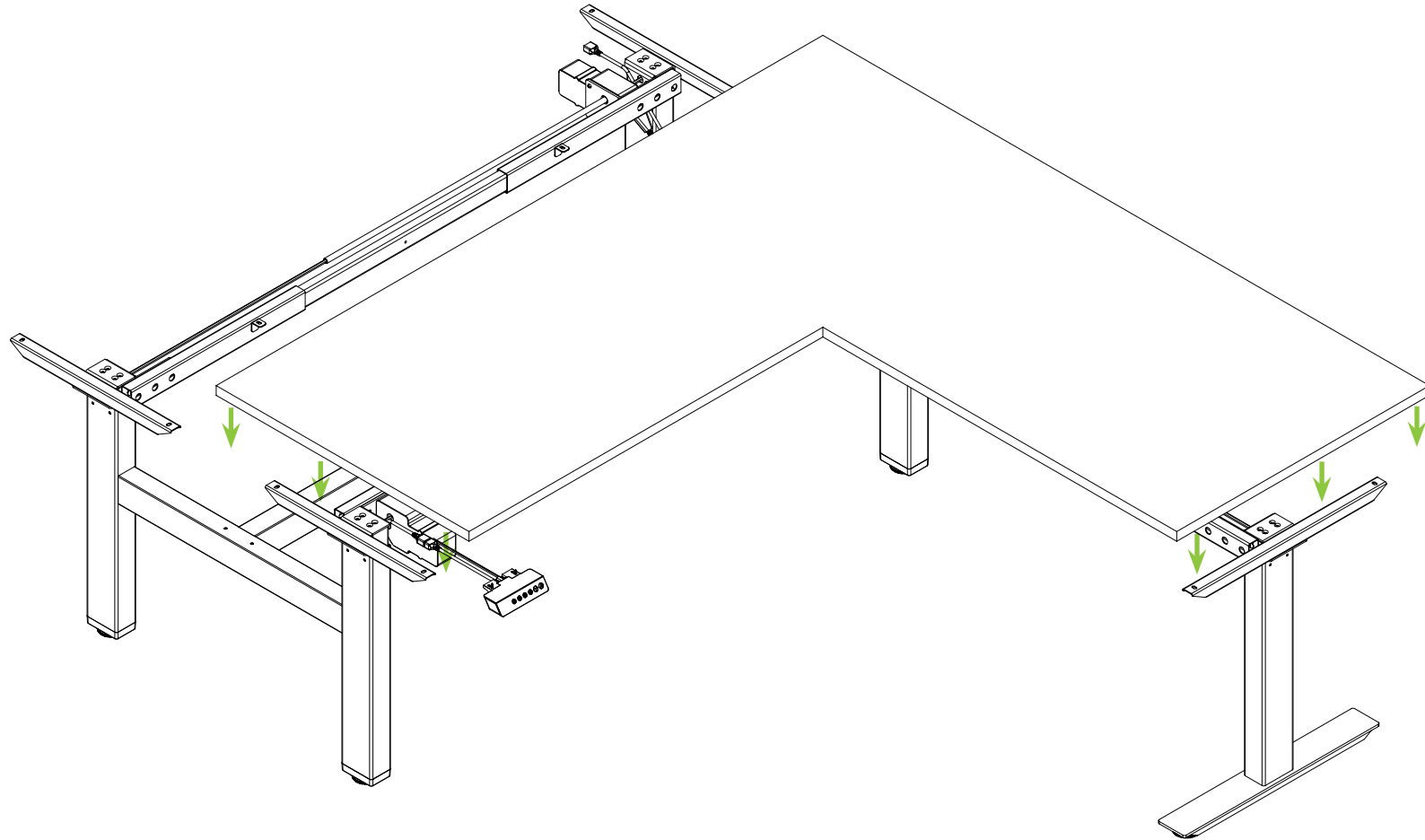

Step 6

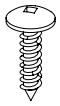

11 x ST5x23

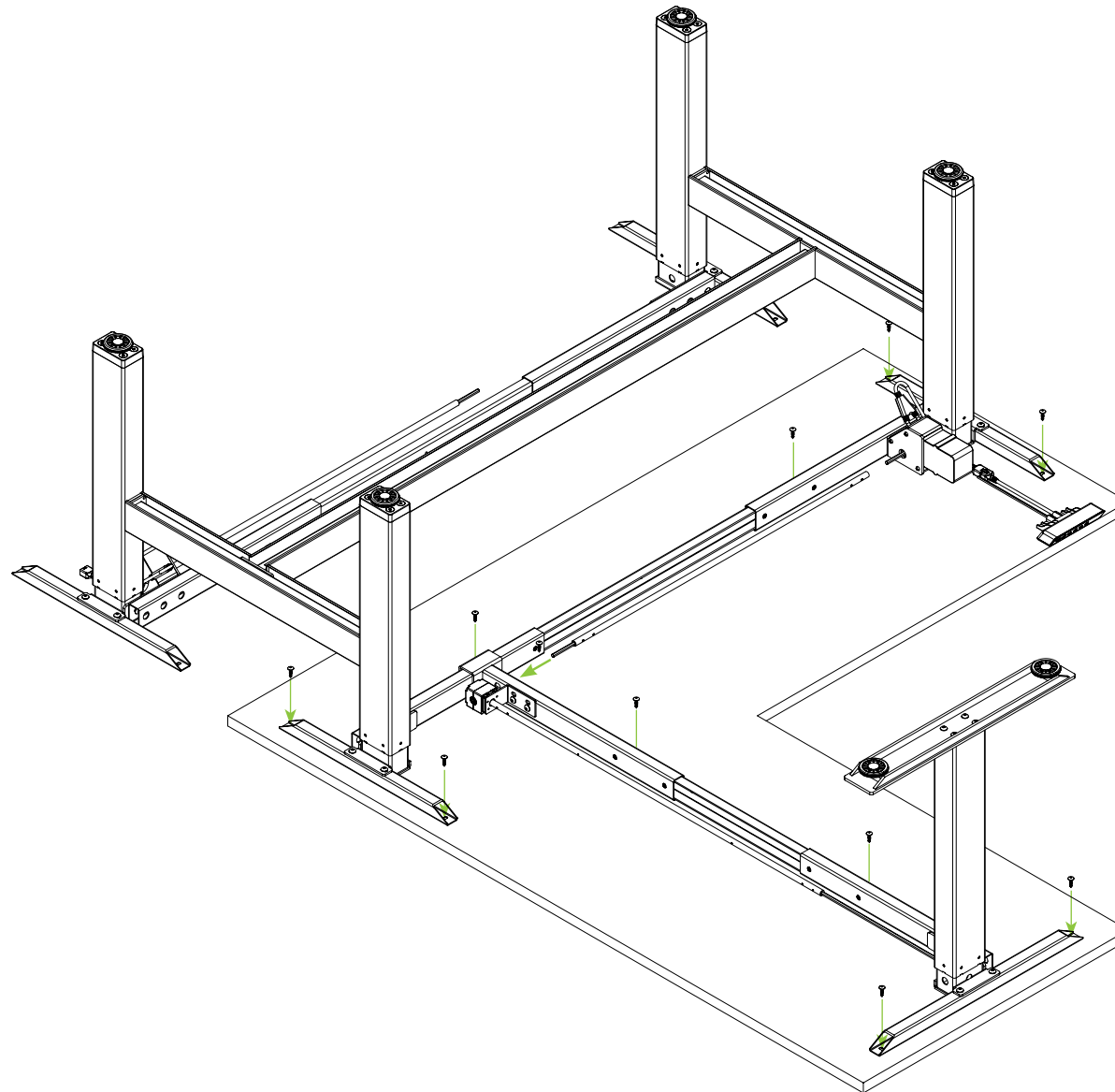

Step 7

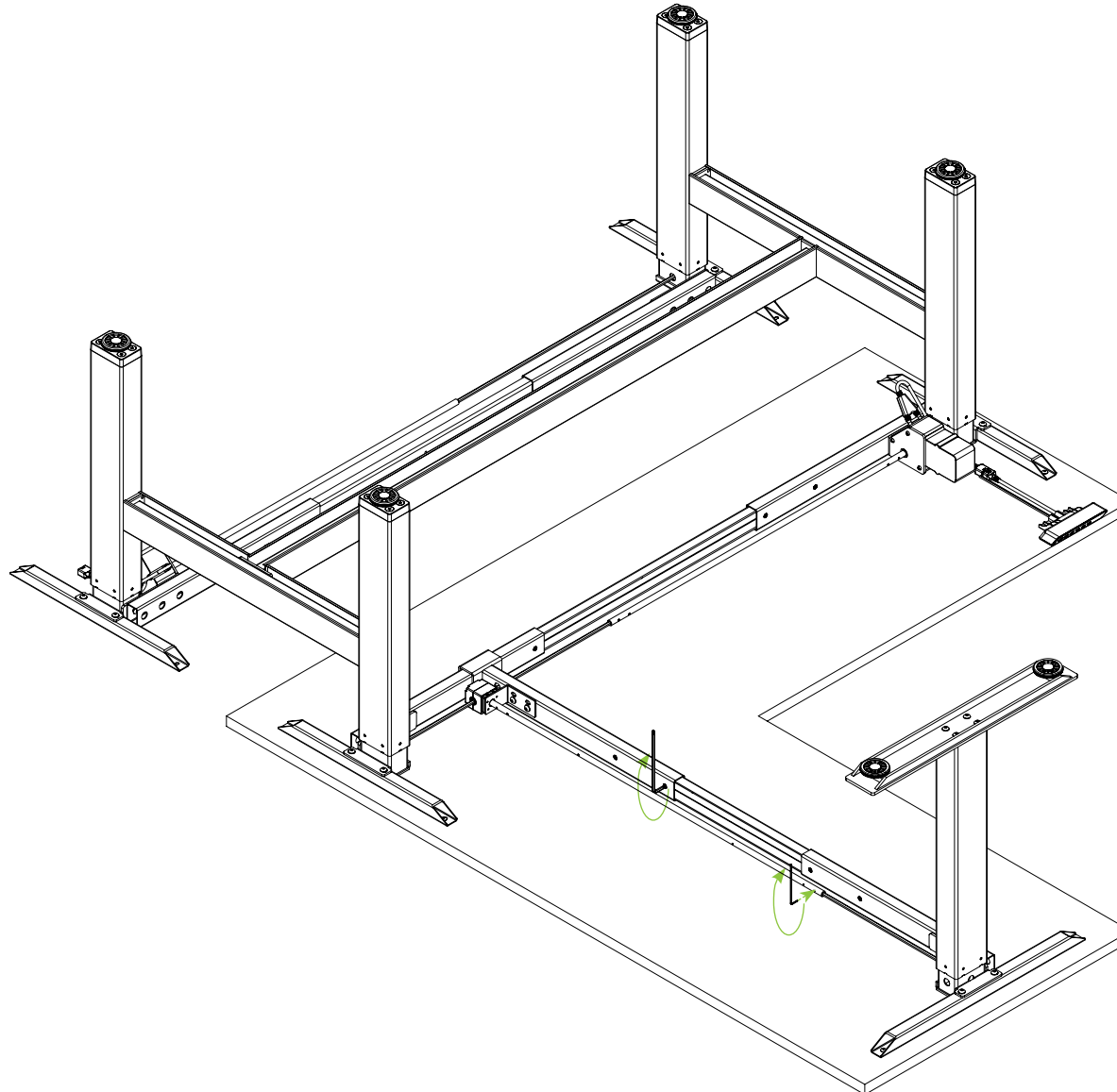

Completed

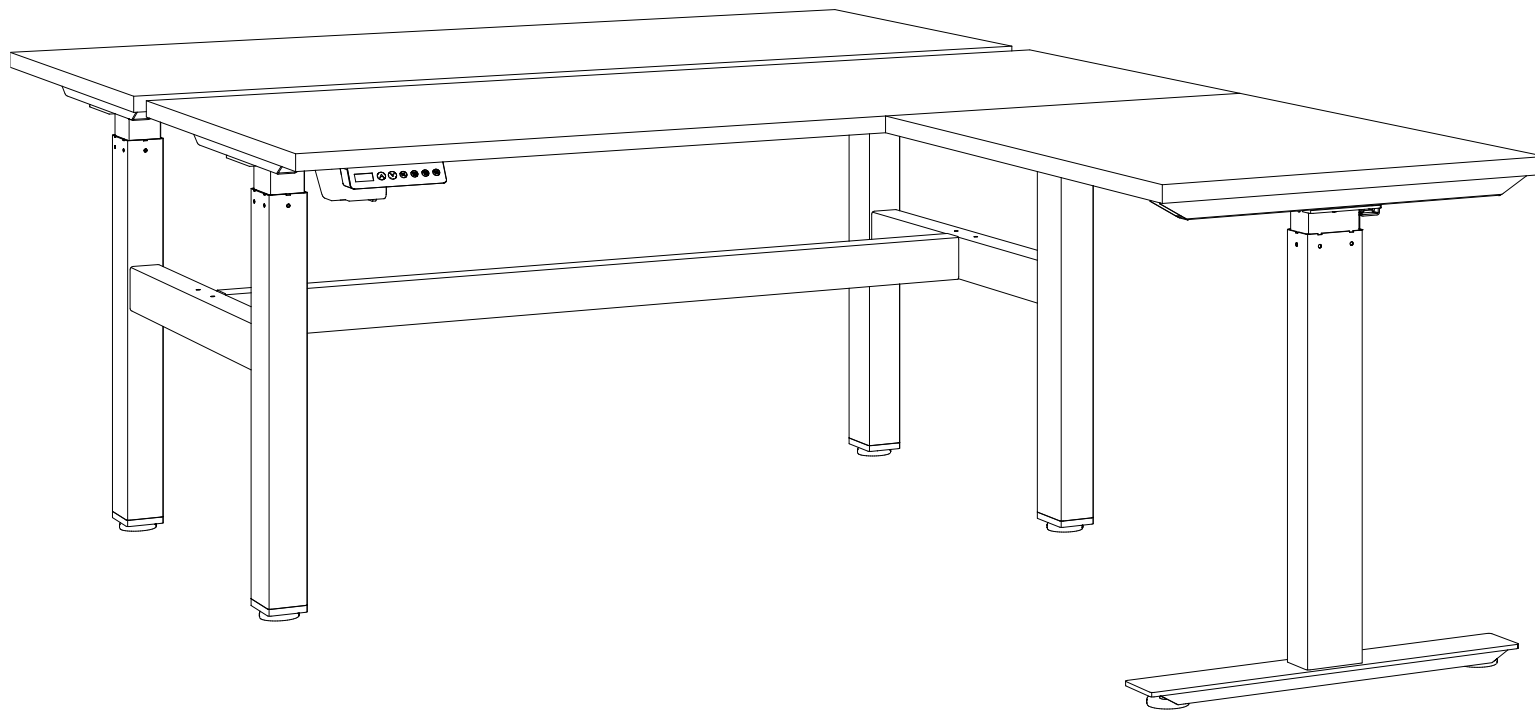



freeway

Agile

Installation Guide - Electric 3 Column

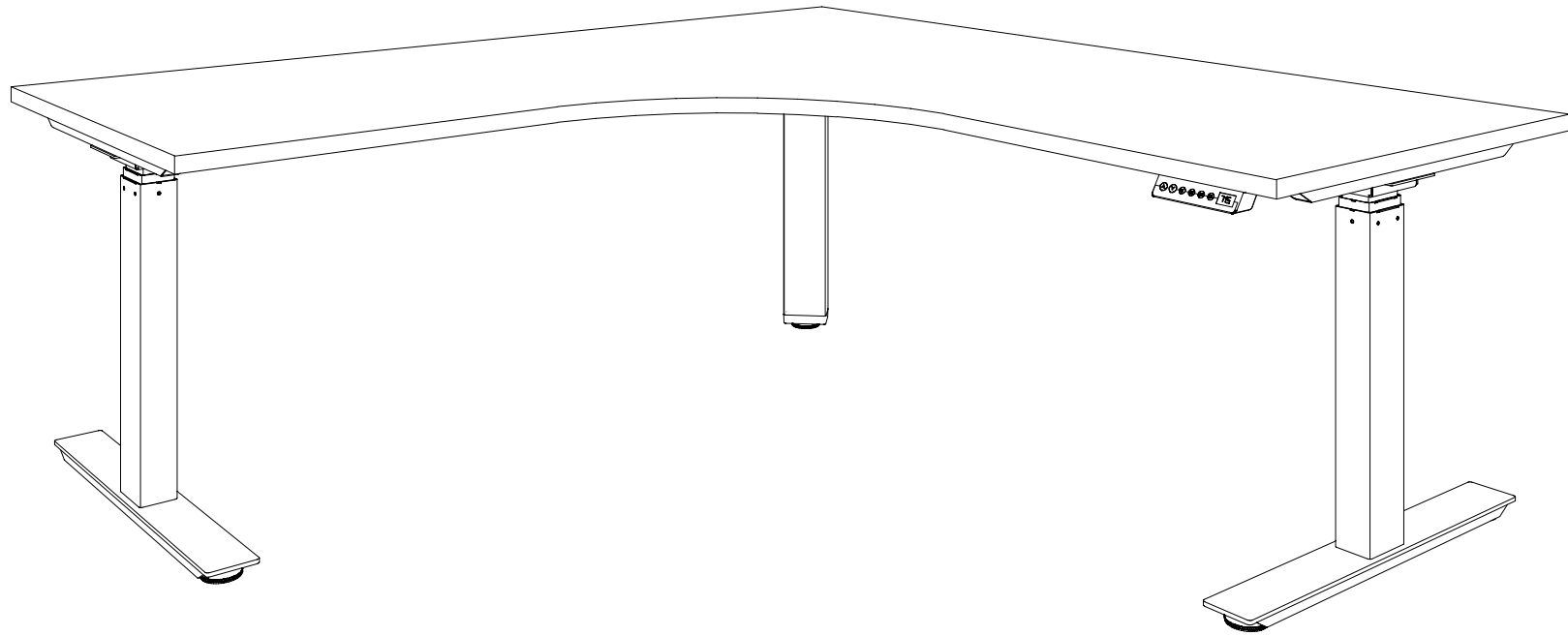

Parts:

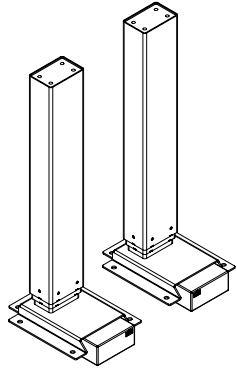

2 x End Leg

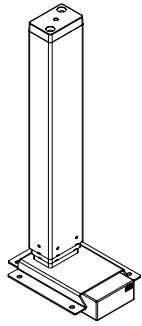

1 x Corner Leg

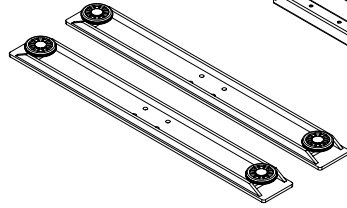

2 x Feet

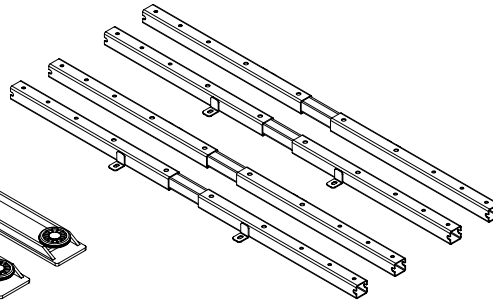

4 x Rail Sets

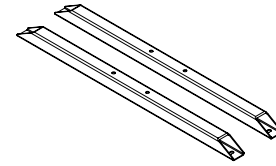

2 x Worktop Support

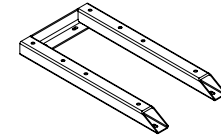

1 x Worktop Support

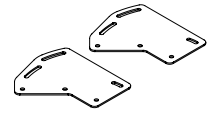

2 x Rail Plate

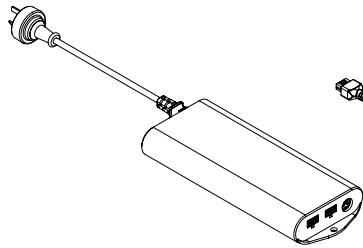

1 x Power Supply

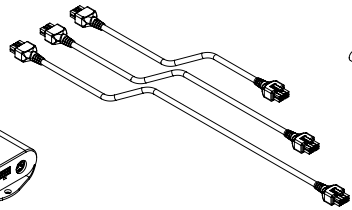

1 x Short Motor Cable
1 x Medium Motor Cable
1 x Long Motor Cable

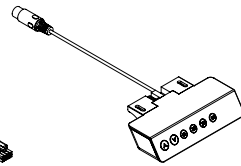

1 x Handset

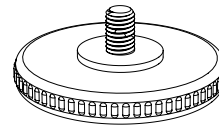

5 x Levelling Foot



8 x M8x25



28 x M8x10



16 x ST5.0x23



2 x ST4.2x16



2 x ST3.5x16

Step 1



8 x M8x10

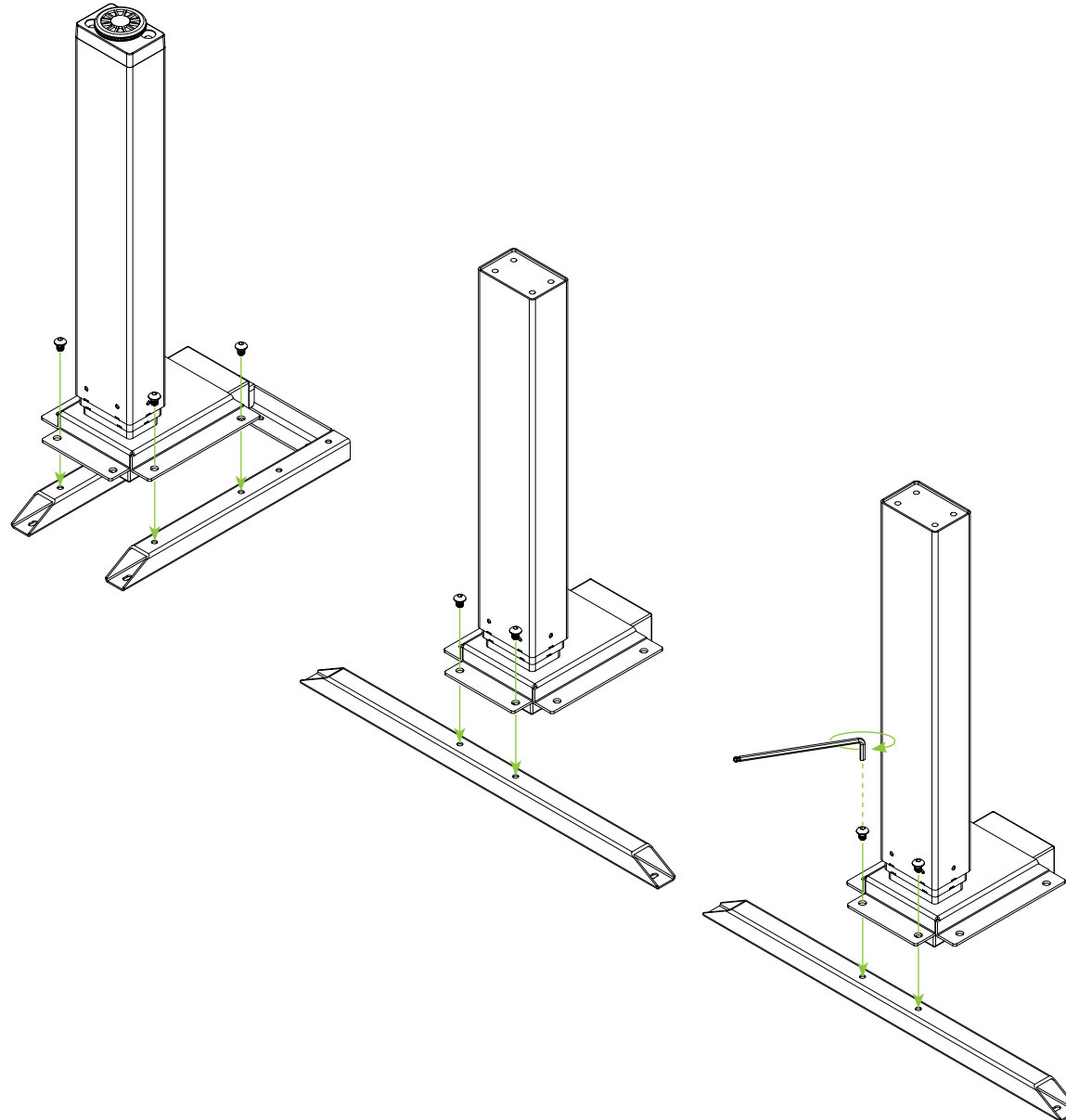

Step 2



4 x M8x10

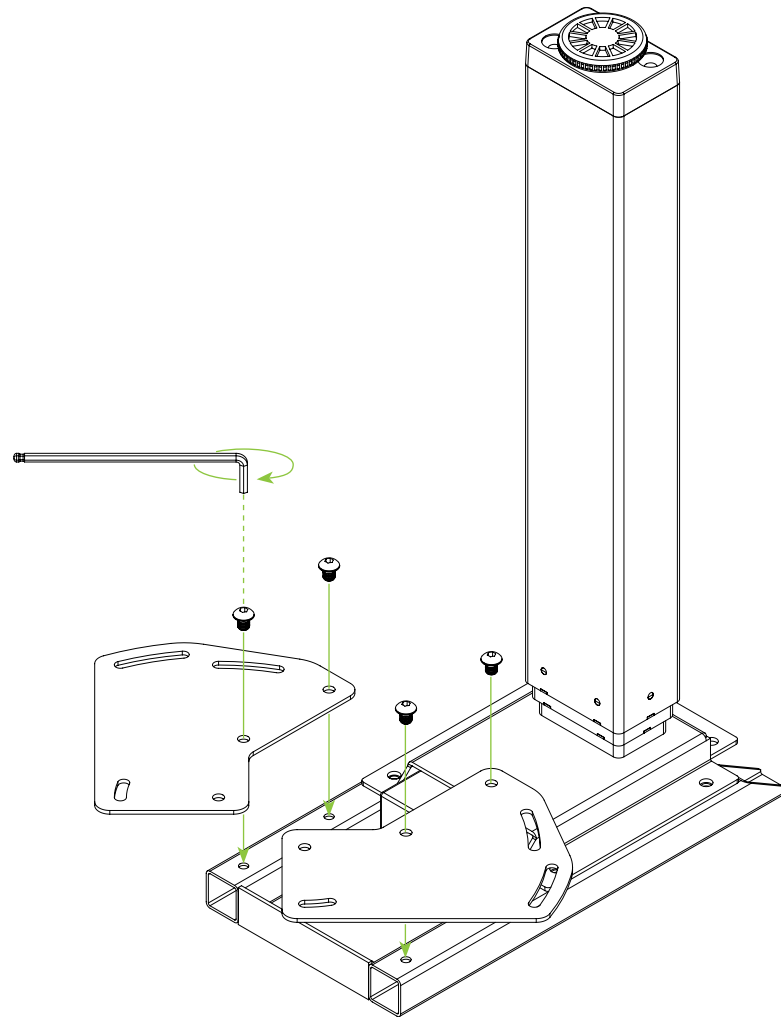

Step 3



16 x M8x10

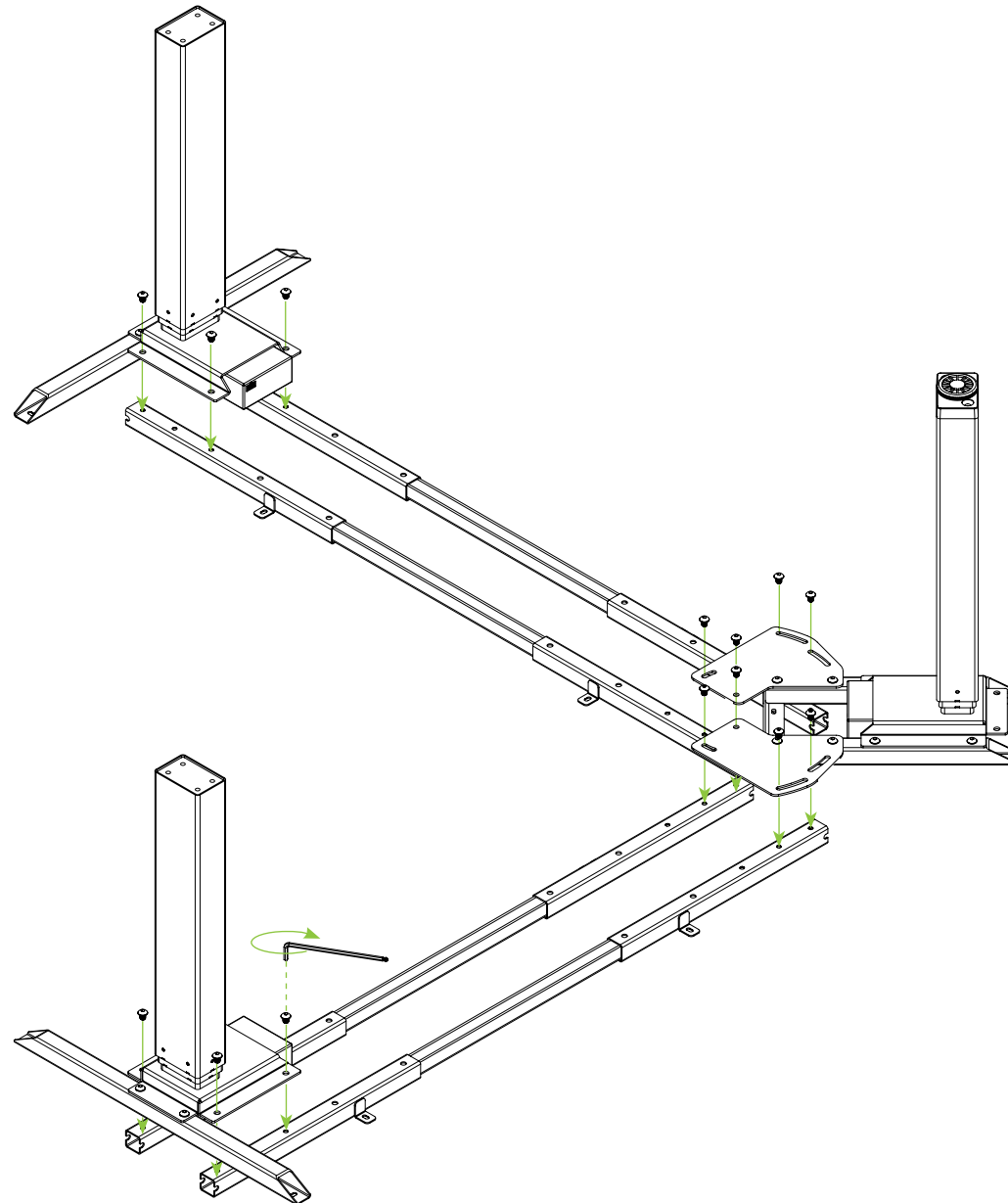

Step 4

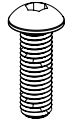

8 x M8x25

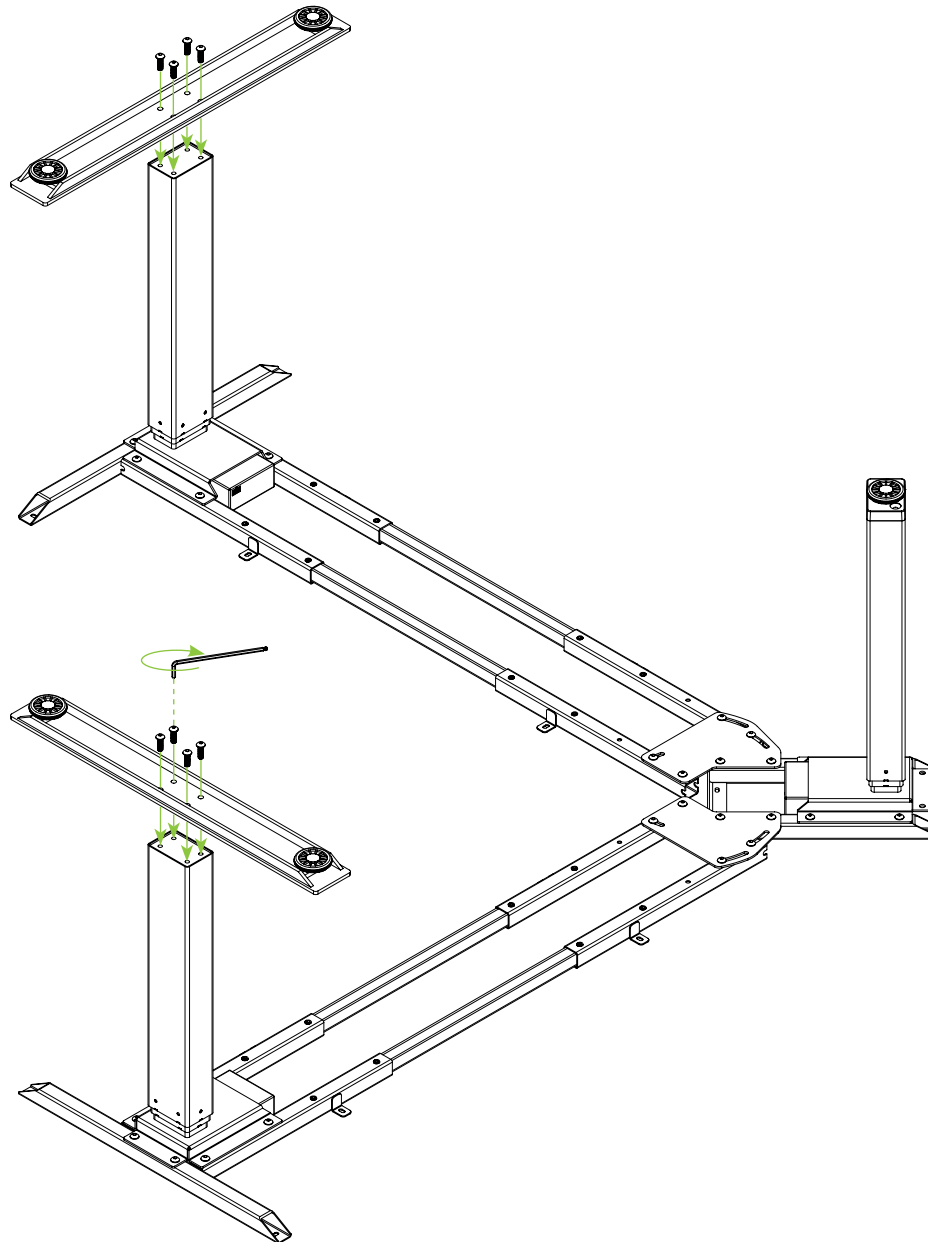

Step 5



16 x ST5.0x23

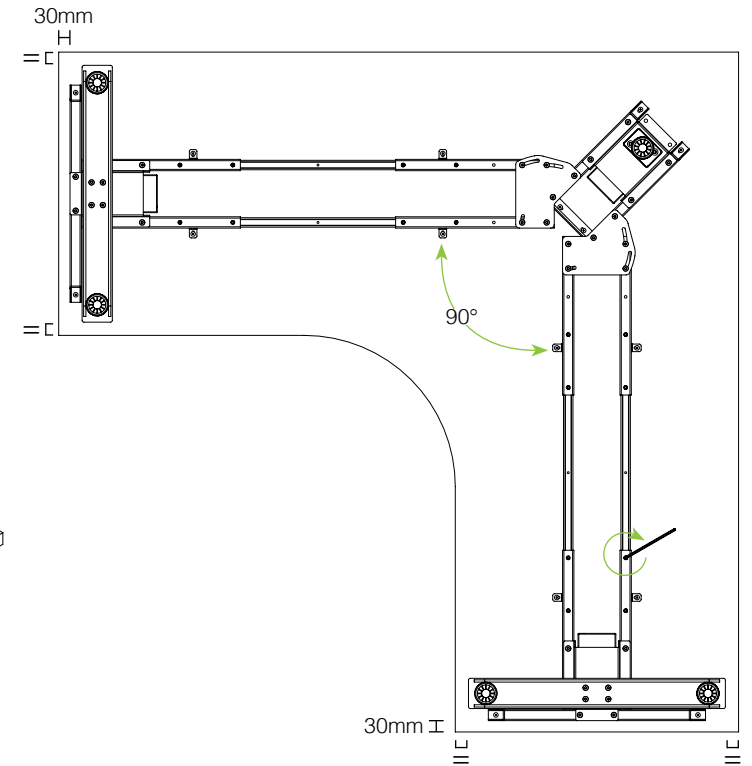
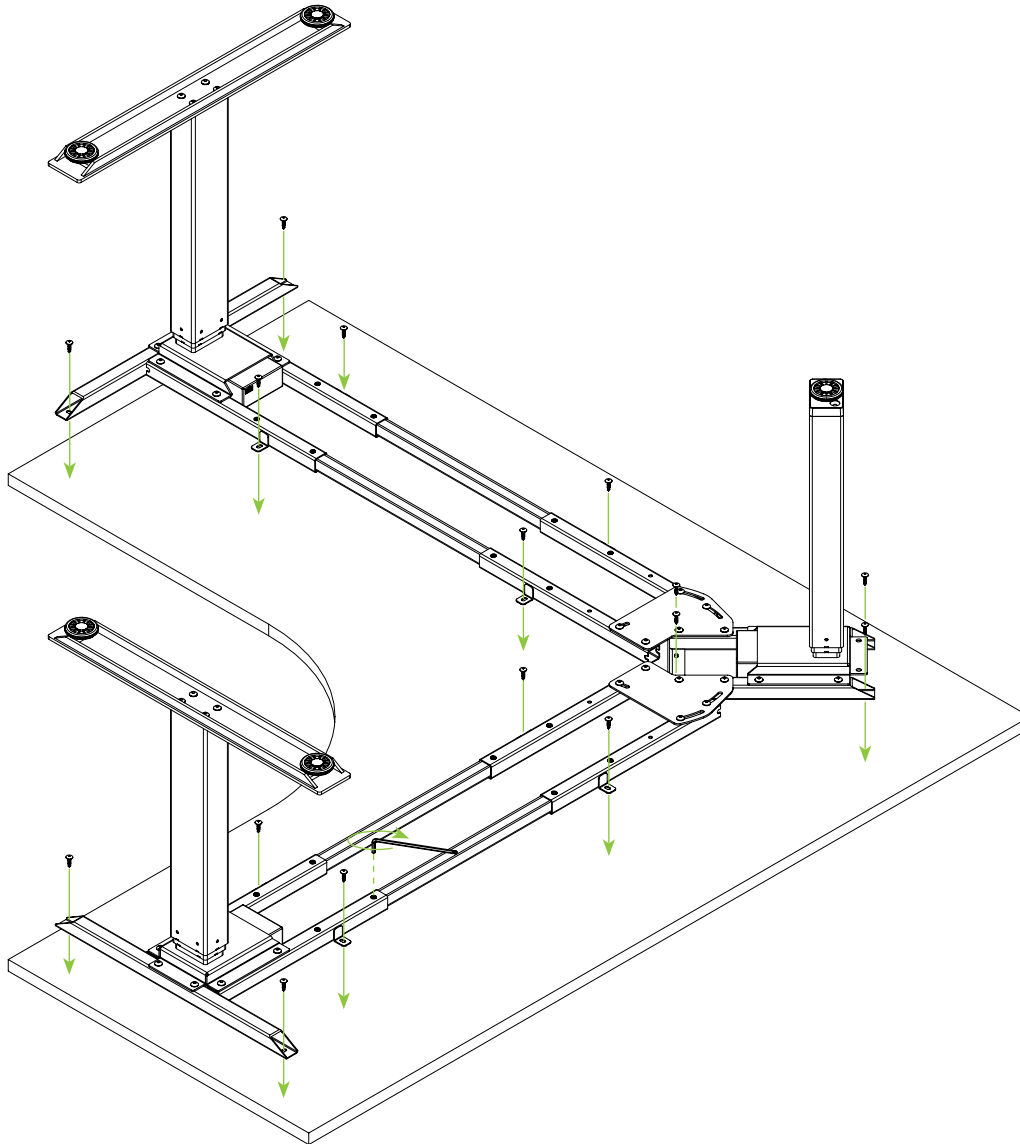

Step 5a

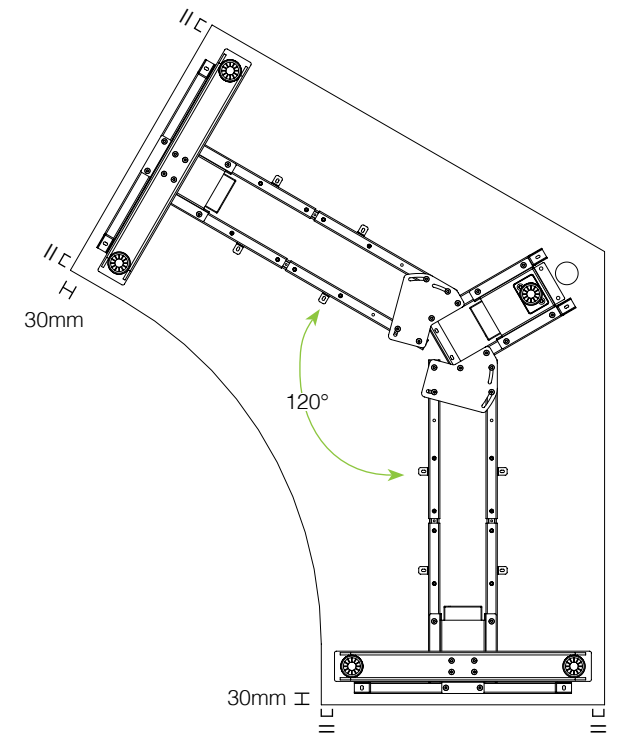
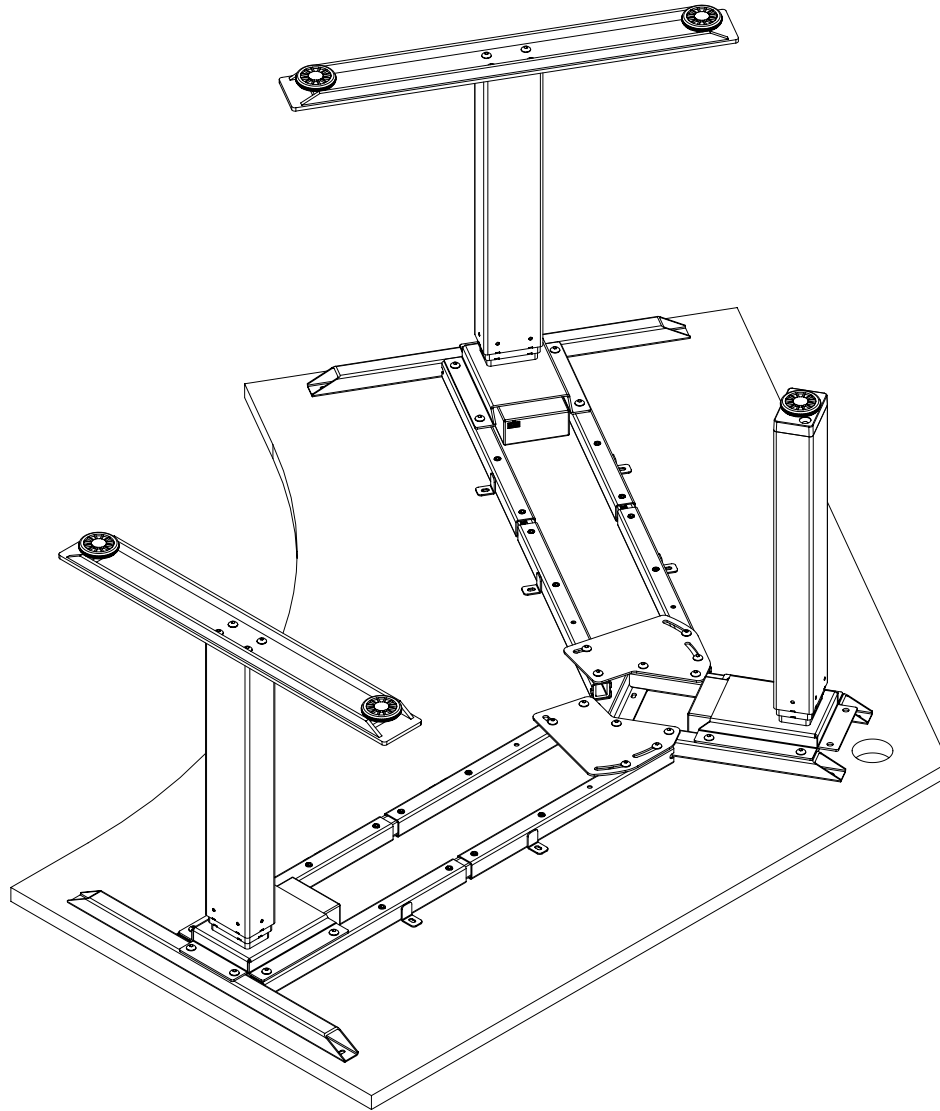

Step 6

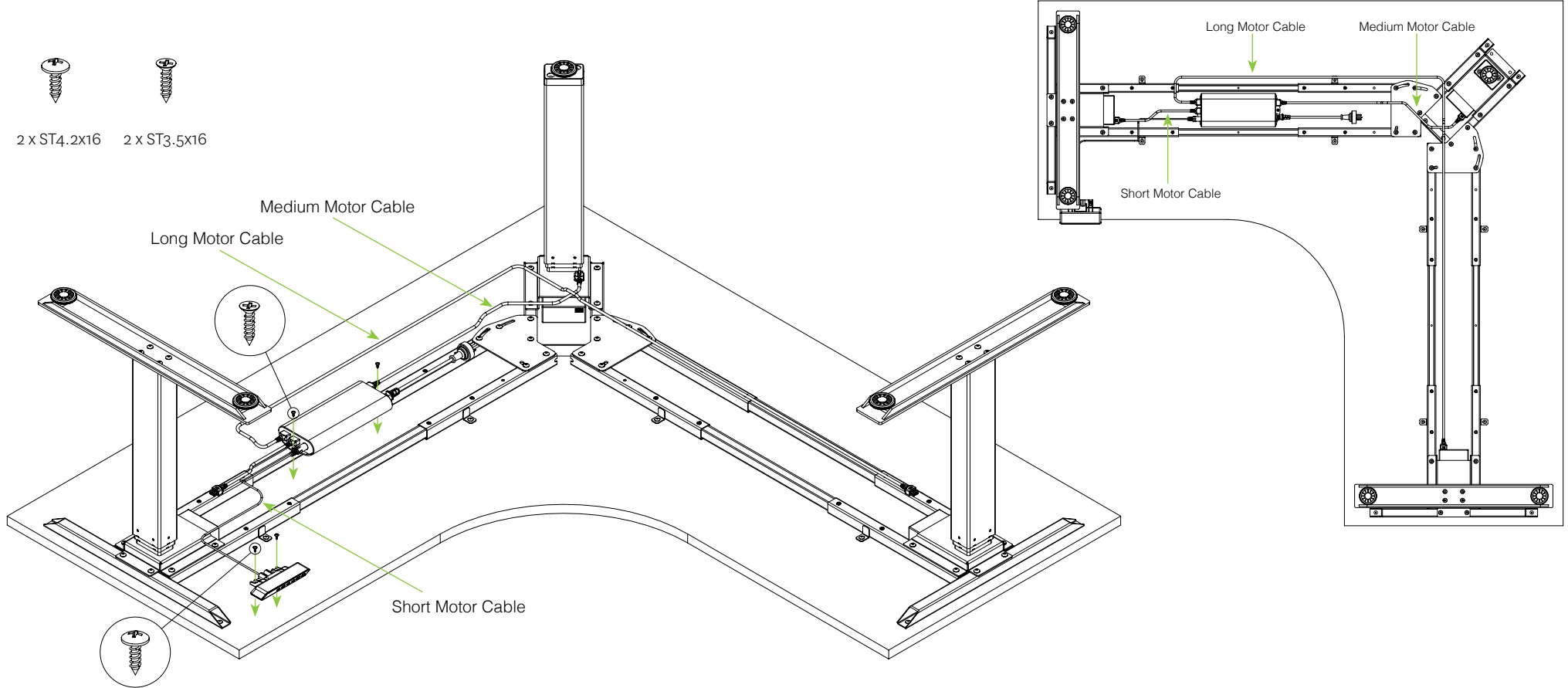

Agile - Optional Screen Brackets

Installation Guide

Step 1

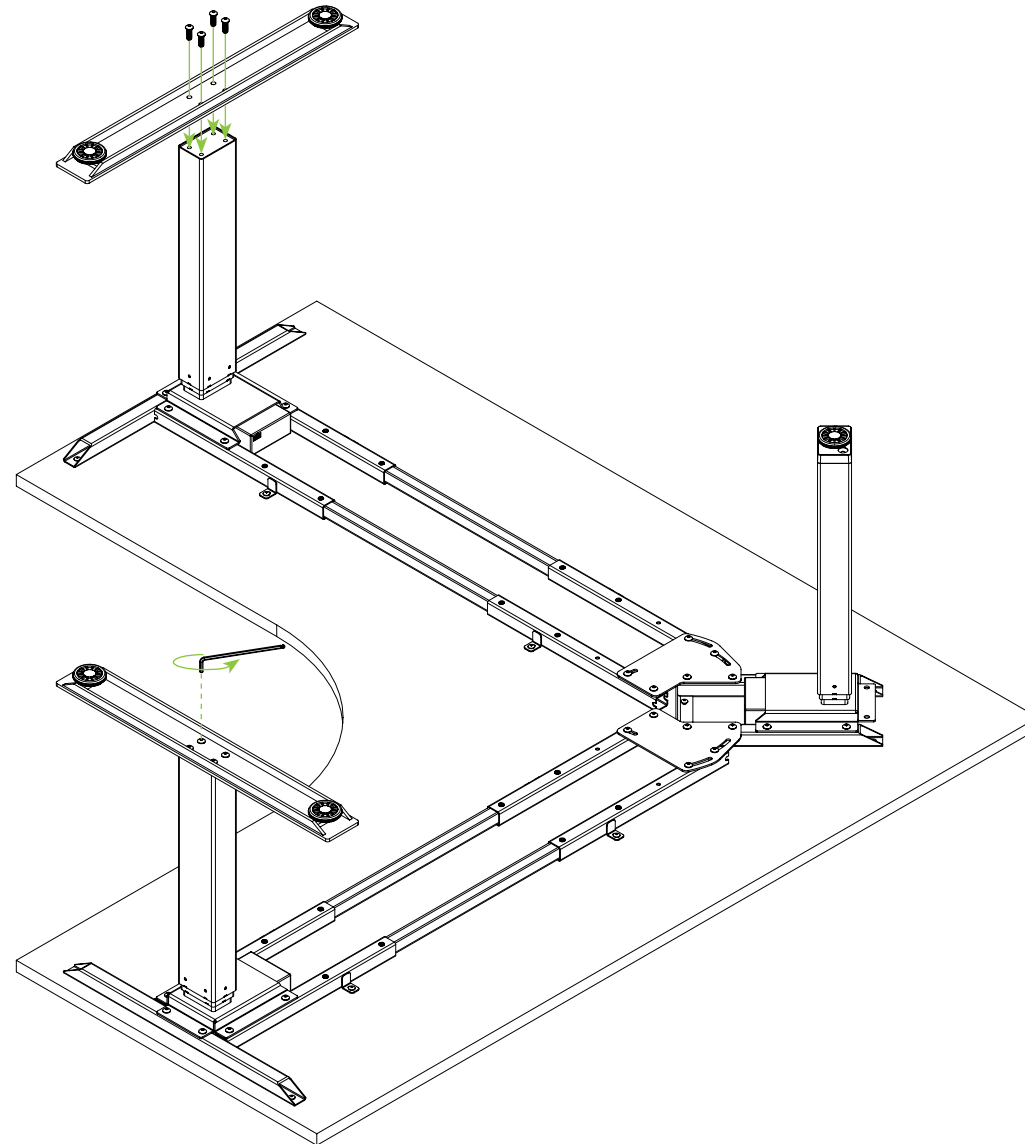

Step 2

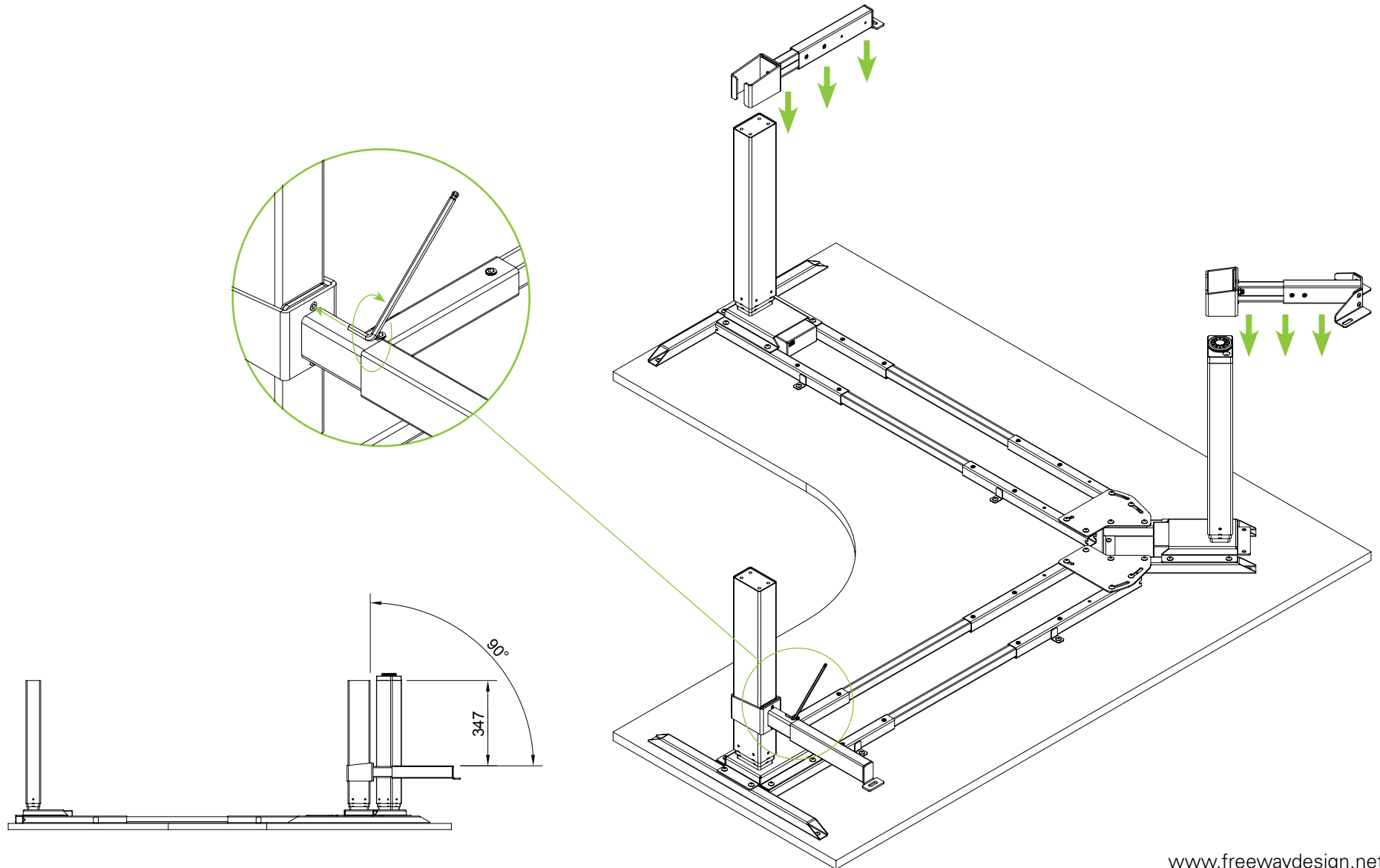

Agile - Optional Screen Brackets

Installation Guide

Step 3

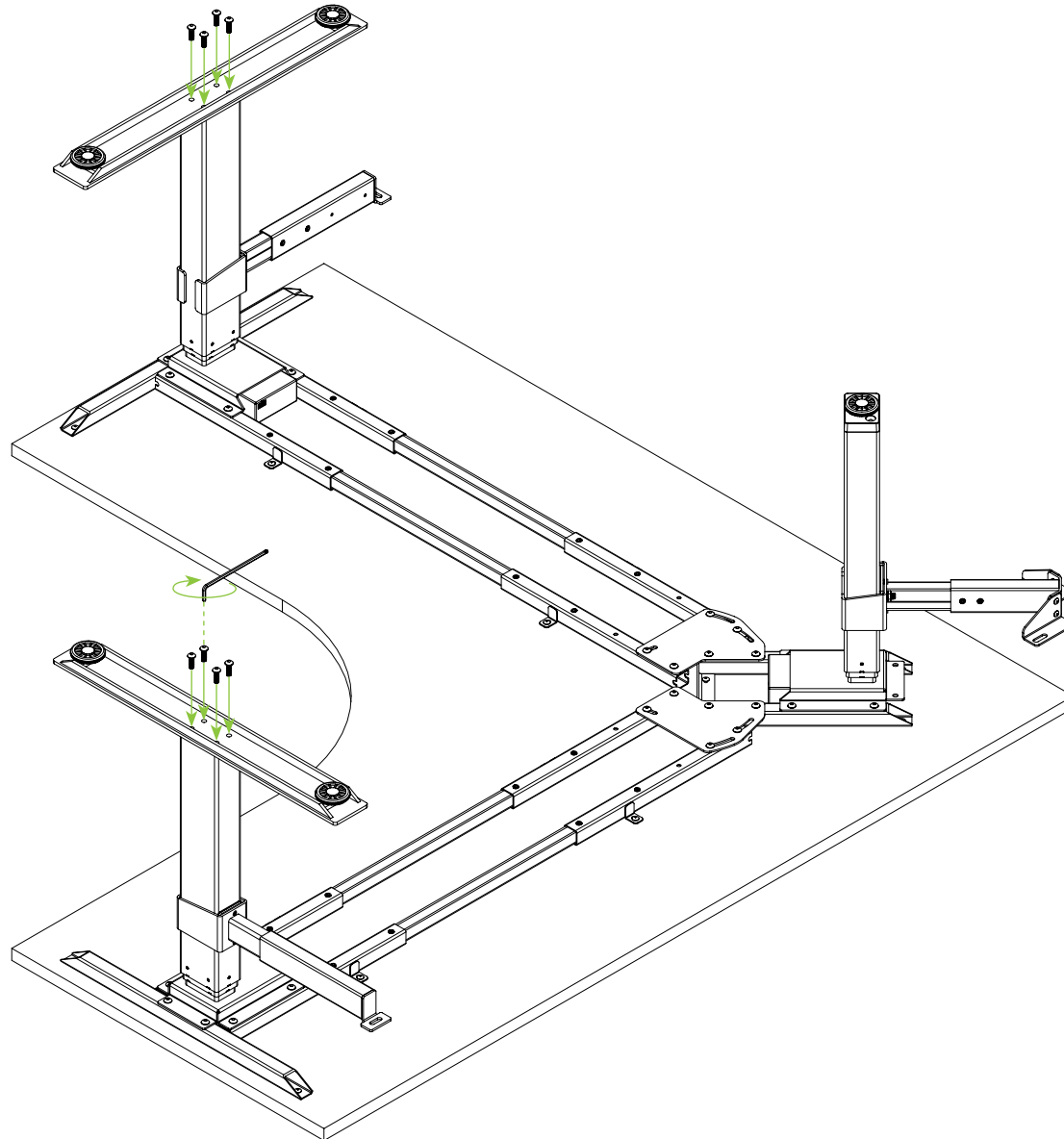

Step 4

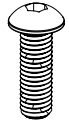

2 x M8x25

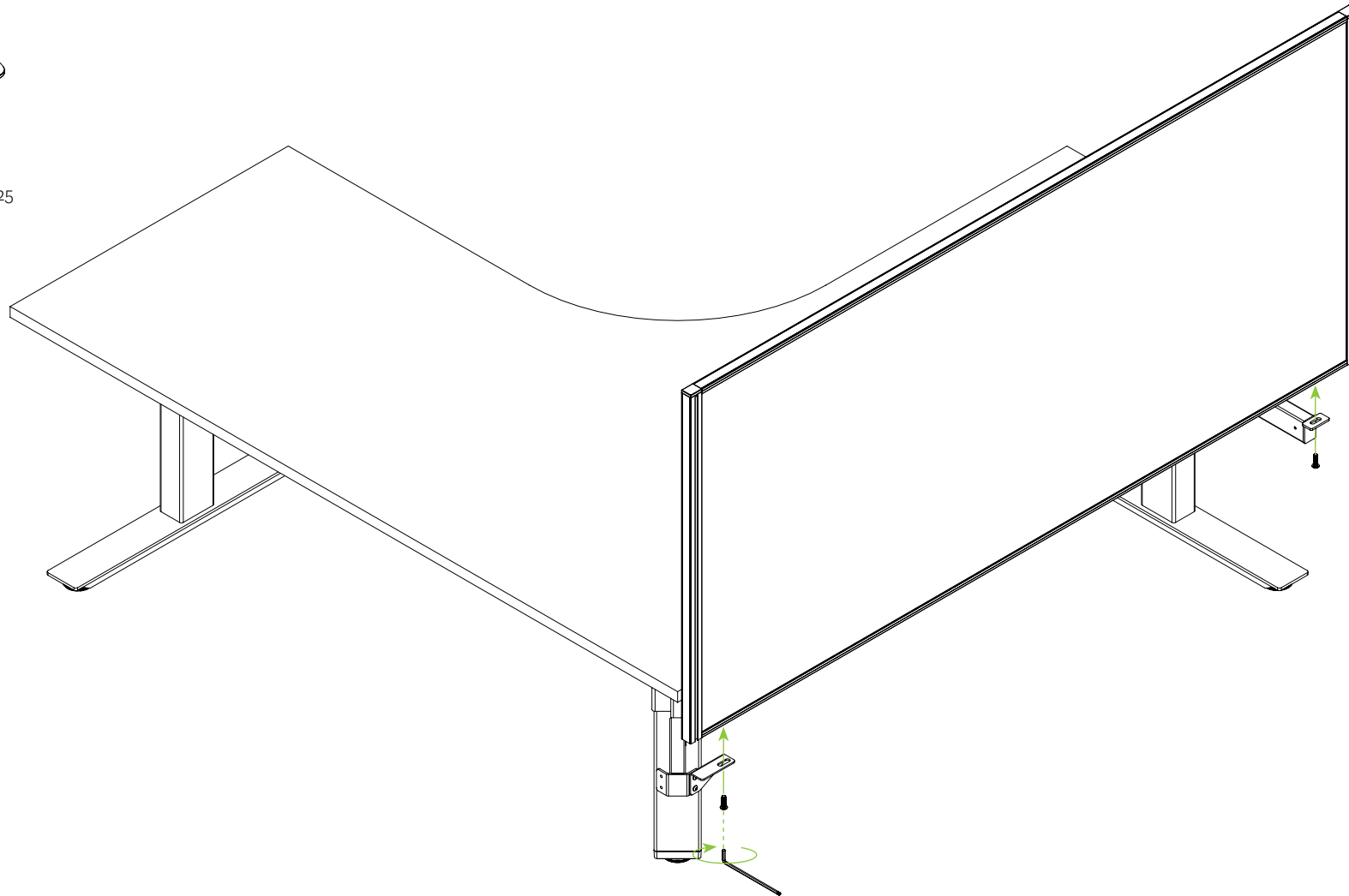

Agile - Optional Screen Brackets

Installation Guide

Step 5



4 x ST5.0x23

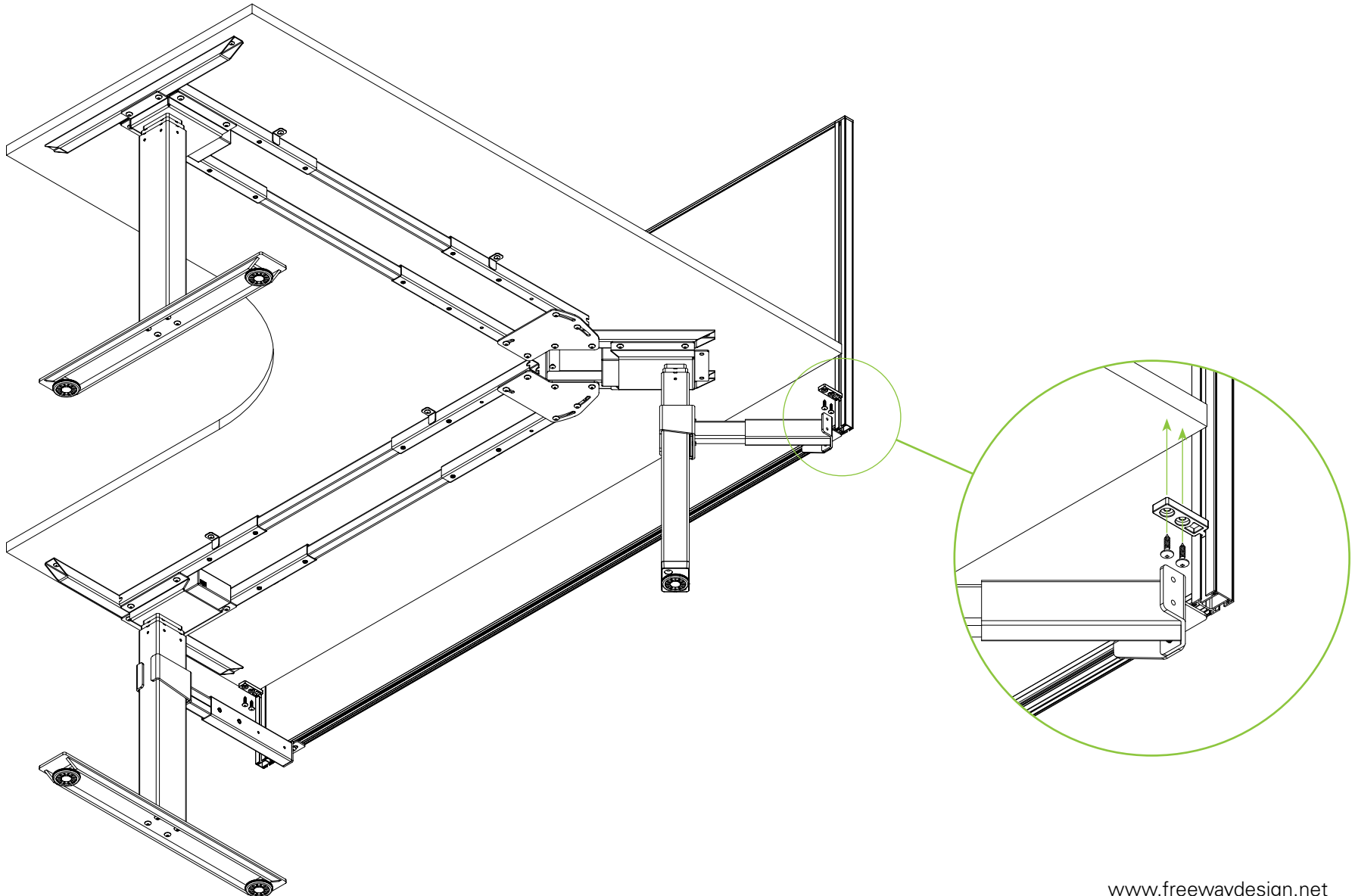

Agile - Optional Screen Brackets

Installation Guide

Step 6

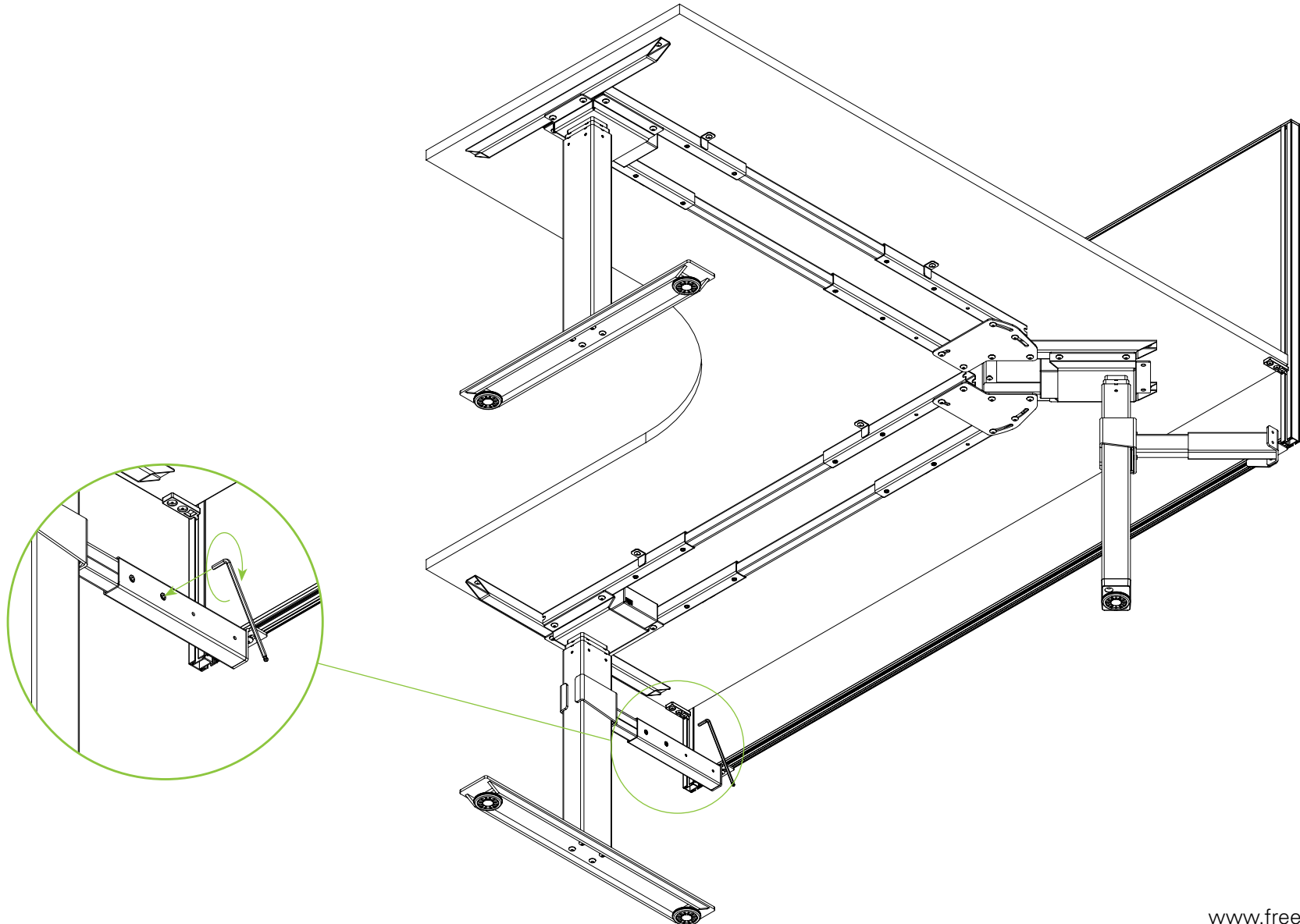

Directions For Use

IMPORTANT

Please carefully read the assembly manual and direction for use prior to instalment, use and maintenance of the table frame to gain a complete understanding of its contents. It provides you with important information about the safety, use, installation and maintenance of the table.

WARNING: FAILURE TO COMPLY WITH OR OBSERVE ALL ASSEMBLY, SAFETY AND OPERATION INSTRUCTIONS REGARDING THE USE OF THIS PRODUCT MAY RESULT IN SERIOUS BODILY INJURY.

SAFETY

- The table must be used in a safe manner. Inappropriate use may cause damage to the table and/or cause bodily harm to the user or persons nearby.
- Do not tamper with electrical components as this may lead to serious bodily harm.
- Only connect the electric table frames to the prescribed mains power voltage
- Do not use the table frame to lift people.
- Please retain this operation manual and pass it on to any future owner.

USAGE

- The height-adjustable table is designed for use in dry work environments only.
- The table height is infinitely adjustable within its height range so that it can be set to the user's most ergonomic working height. The user should seek professional help to establish their optimum working height.
- The table has been designed as a devise to elevate the users work surface and associated office peripherals. Do not use the table frame for any other purposes than that which it has been designed for. Any other use is at user's own risk!
- Do not crawl, lie or move around under the table frame, and do not sit or stand on the table frame.
- CHILDREN should only use the table when supervised by adults.
- Liability: The manufacturer accepts under no circumstances warranty claims or liability claims for damages arising from improper use or handling of the table frame other than that described in this operation manual.

SET UP AND INSTALLATION

Assemble the table frame according to the assembly instructions on pages 3 - 9.

- Place the table in a safe distance from window frames, radiators, furniture etc. so that persons cannot become trapped.
- Level the table with the adjustable feet ensuring that the table is stable.
- Check that no cables can get jammed.
- Connect the table to the 110 or 230 VAC power outlet.

The table is now ready for use.

Directions For Use

MAINTENANCE

- The table does not require any maintenance by the user
- The table is only to be cleaned with a wrung cloth.

TECHNICAL DATA

Height Range: 635-1290mm including worktop

Speed: ~30mm/s

Input Voltage: 90-230V AC 50-60Hz, 300VA

Output Voltage: 24V DC Max.10A

Duty Cycle: 10% max. 2min on/18min off

