

OLG







AXIS HEIGHT ADJUSTABLE FLIP TABLE



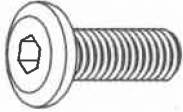
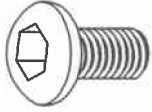
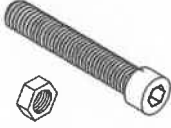

Assembly Instructions

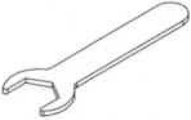
Axis Height Adjustable Flip Table

Hardware List

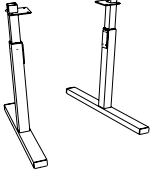
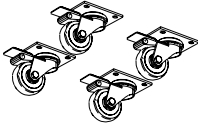
<p>1</p>  <p>SCREW M8 x 16mm 25pcs</p>	<p>2</p>  <p>SCREW M6 x 8mm 9pcs</p>	<p>3</p>  <p>SCREW M10 x 50mm 3pcs</p>	<p>4</p>  <p>WASHER 6pcs</p>	<p>4</p>  <p>SCREW 5*60 9pcs</p>	
<p>5</p>  <p>PLASTIC WASHER 6pcs</p>	<p>6</p> <p>HEX KEY 5mm 1pc</p>	<p>7</p> <p>HEX KEY 4mm 1pc</p>	<p>8</p> <p>HEX KEY 2.5mm 1pc</p>	<p>9</p> <p>HEX KEY 8mm 1pc</p>	<p>10</p>  <p>WRENCH 1pc</p>

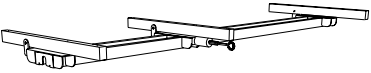
Parts List

<p>1</p>  <p>2 x Legs</p>	<p>2</p>  <p>4 x Castors</p>	<p>3</p>  <p>Handle</p>
<p>4</p>  <p>Pre-assembled Rail</p>	<p>5</p>  <p>Rail</p>	<p>6</p>  <p>Drivebar</p>

Axis Height Adjustable Flip Table

Assembly Instructions

STEP 1:

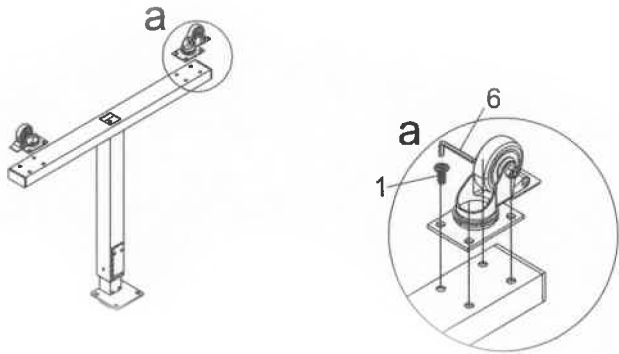

STEP 2:

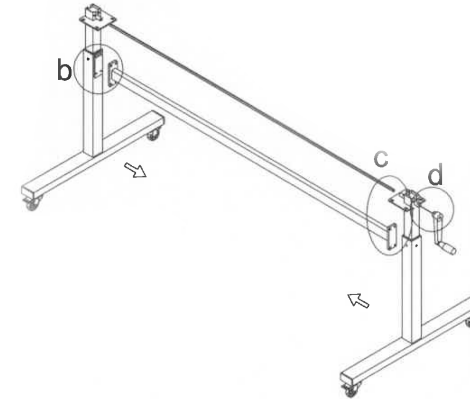

STEP 3:

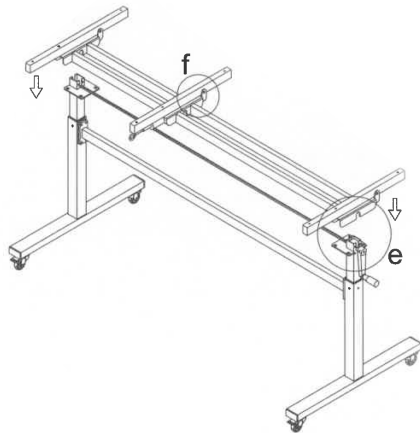

COMPLETED ASSEMBLY:

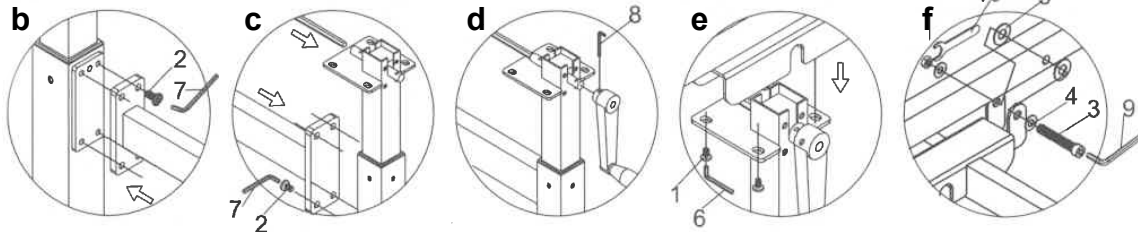
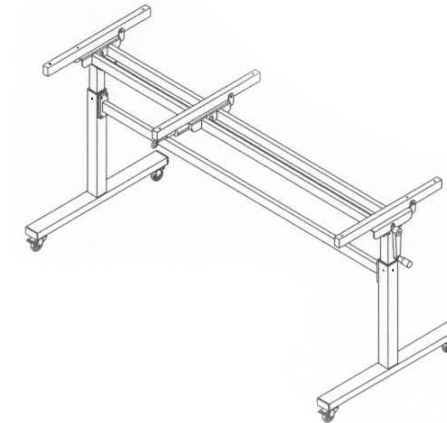

* Do not tighten until the end

* Do not tighten until the end

Axis Height Adjustable Flip Table

Assembly Instructions

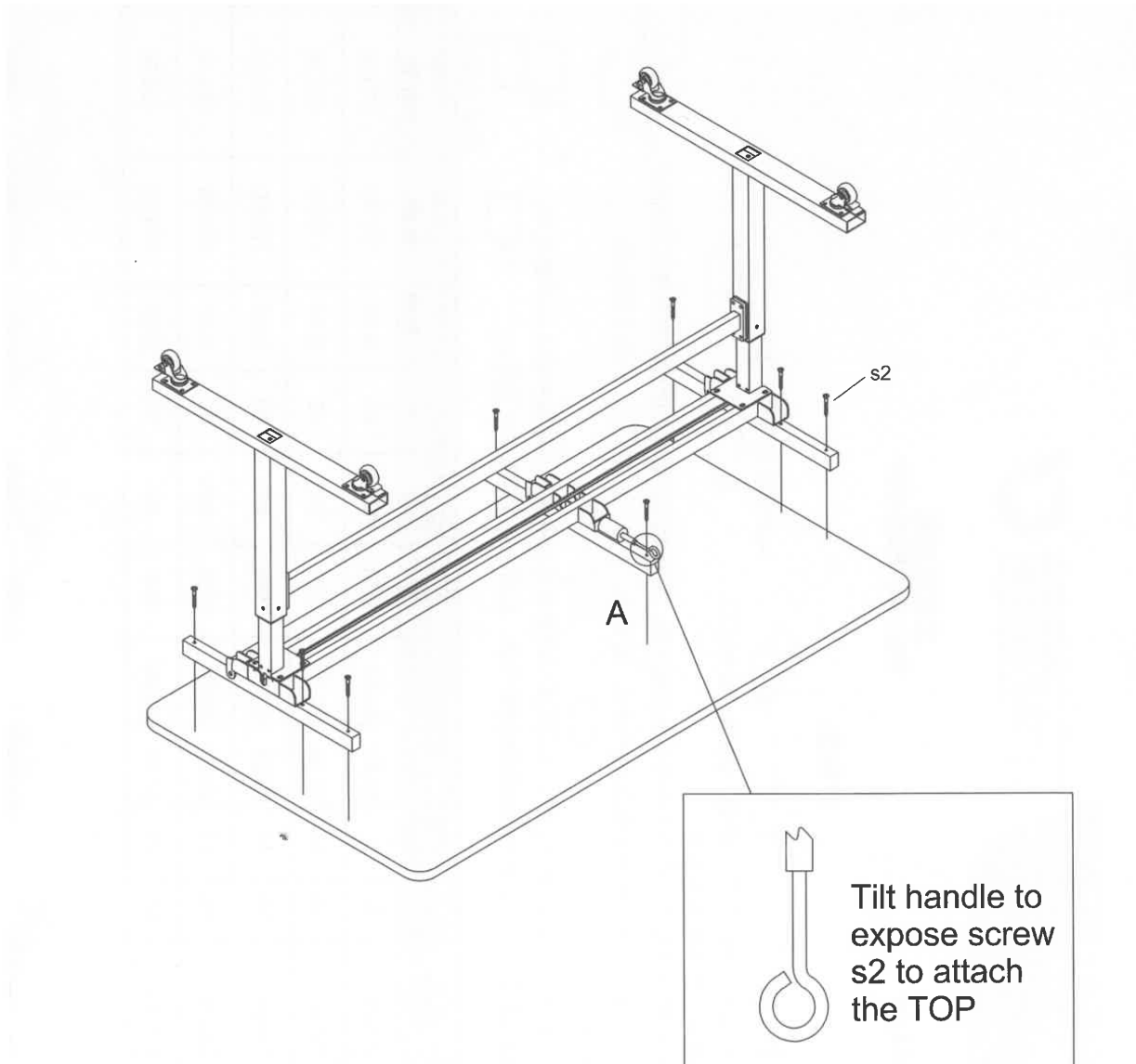

Axis Height Adjustable Flip Table

Assembly Instructions



You have now successfully completed the assembly.



Sydney 02 8188 2732
Melbourne 03 9111 0315
Brisbane 07 3733 1923
Adelaide 08 7111 0810
Perth 08 9468 2707

info@olgoffice.com

myolg.online | olgoffice.com | officedesigner.net | motionoffice.com