

ASSEMBLY INSTRUCTION

ITEM NO. : OG-EKDR96

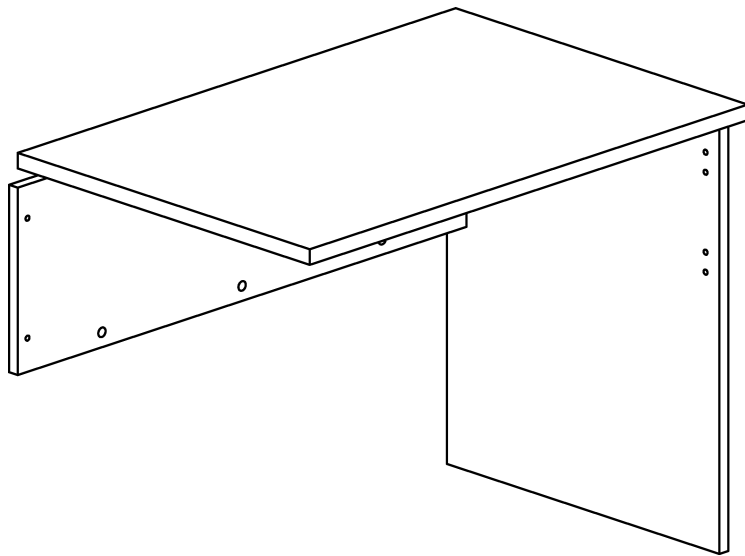

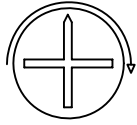

The turning direction of attaching



The arrow direction=front

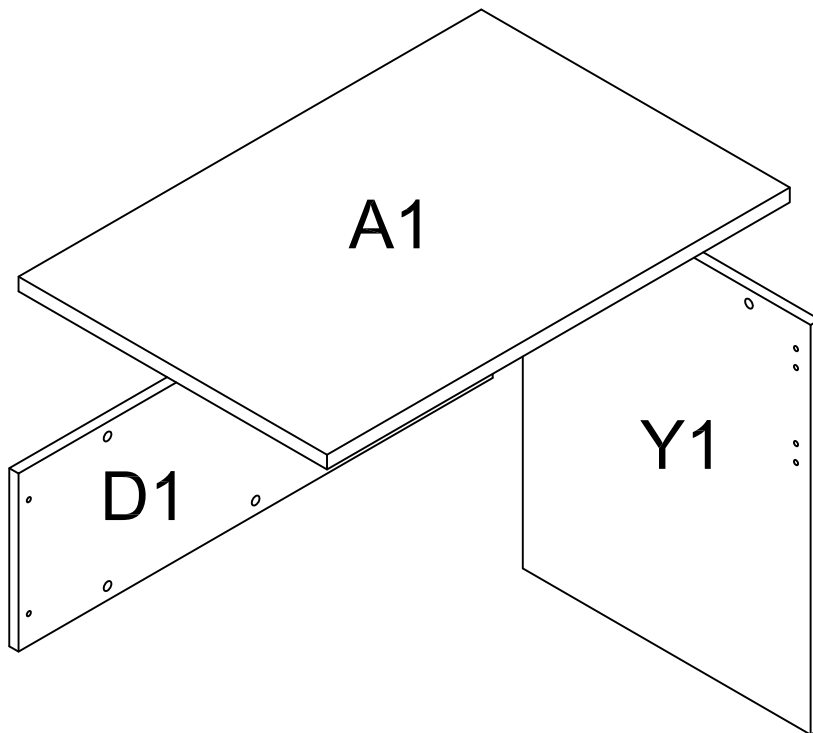

PARTS LIST

ITEM	DESCRIPTION	QTY.	ITEM	DESCRIPTION	QTY.
A1	Top panel	1	(c1)	6*35 Cam Bolt	8
D1	Back panel	1	(d1)	8*30 Dowel pin	6
Y1	Partition	1	(c2)	(5/8") Cam Cover	11
			(s1)	4*16 Screw	8
			(b1)	Bracket	2
			(c3)	200*60 Connector	2
			(s4)	4mm Spanner	1
			(s5)	6*12 Screw	16
			(s6)	6*25 Screw	2



(c1) (5/8") Cam Cover-8



(d1) 8*30 Dowel Pin-6



(c2) (5/8") Cam Cover-11



(s1) 4*16 Screw-8

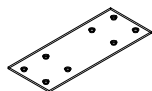

(c3) 200*60 Connector-2



(s5) 6*12 Screw-16



(s6) 6*25 Screw-2



(b1) Bracket-2

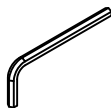

(s4) 4mm Spanner-1

Pre-installed parts

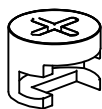

(c5) Cam

STEP 1

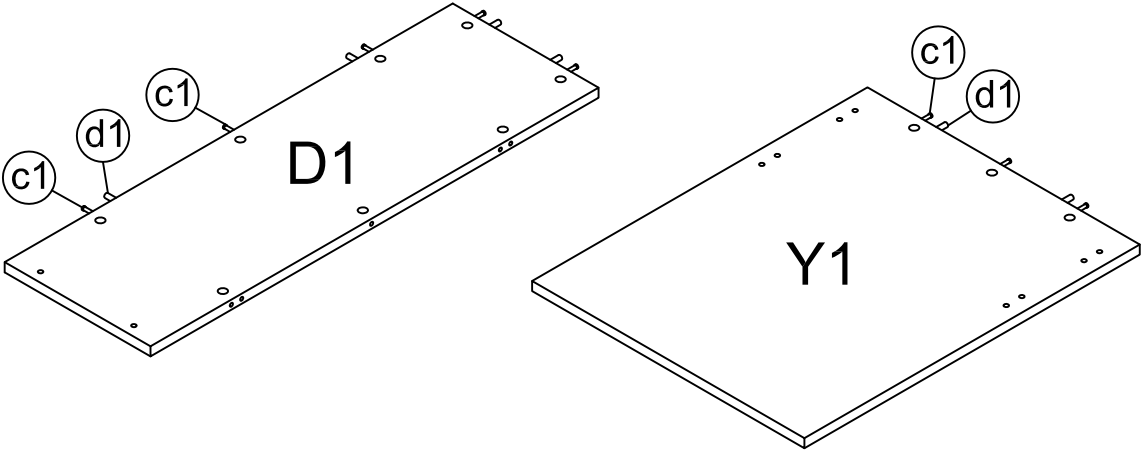

Preparation for Panels Y1 and D1 .

1.Insert dowel pins (d1) and cams bolts into panels Y1 and D1 as illustrated above.

STEP 2

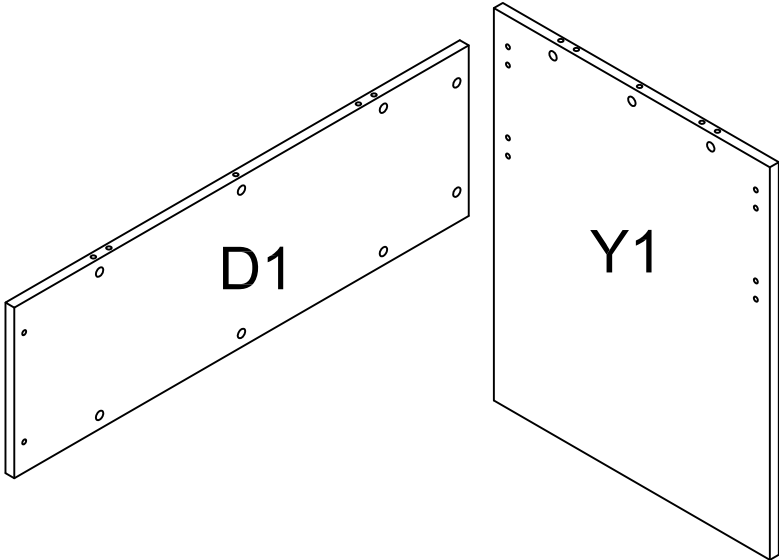

Preparation for Panels Y1 and D1.

1.Connect Cam bolts and dowels on panel D1 to the holes on panel Y1 and tighten in a clockwise direction as illustrated above.

STEP 3

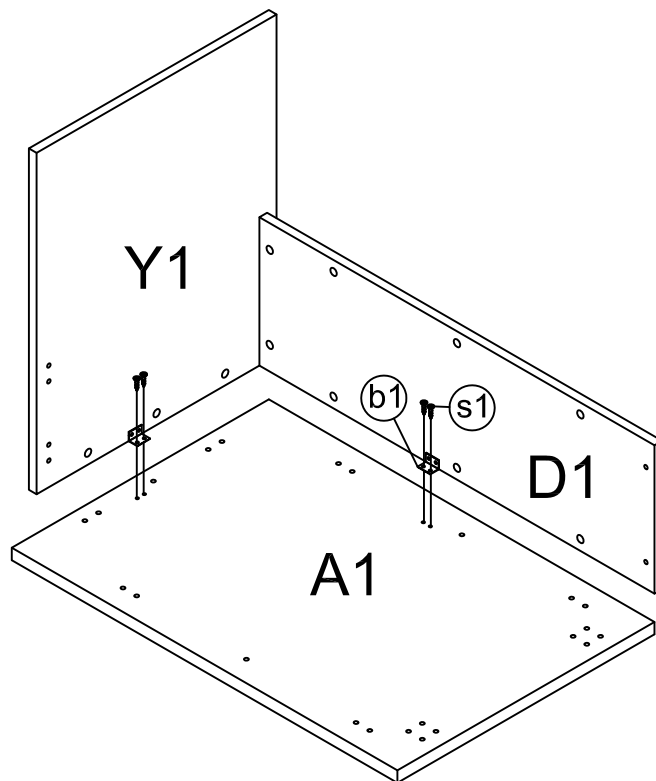

Preparation for Panels D1 .

1. Connect Cam bolts and dowels on panel Y1 and D1 to the holes on panel A1 and tighten in a clockwise direction as illustrated above.
2. Fix Bracket (b1) to panels Y1, D1 and A1 with fix bolts (s1) as illustrated above.

STEP 4

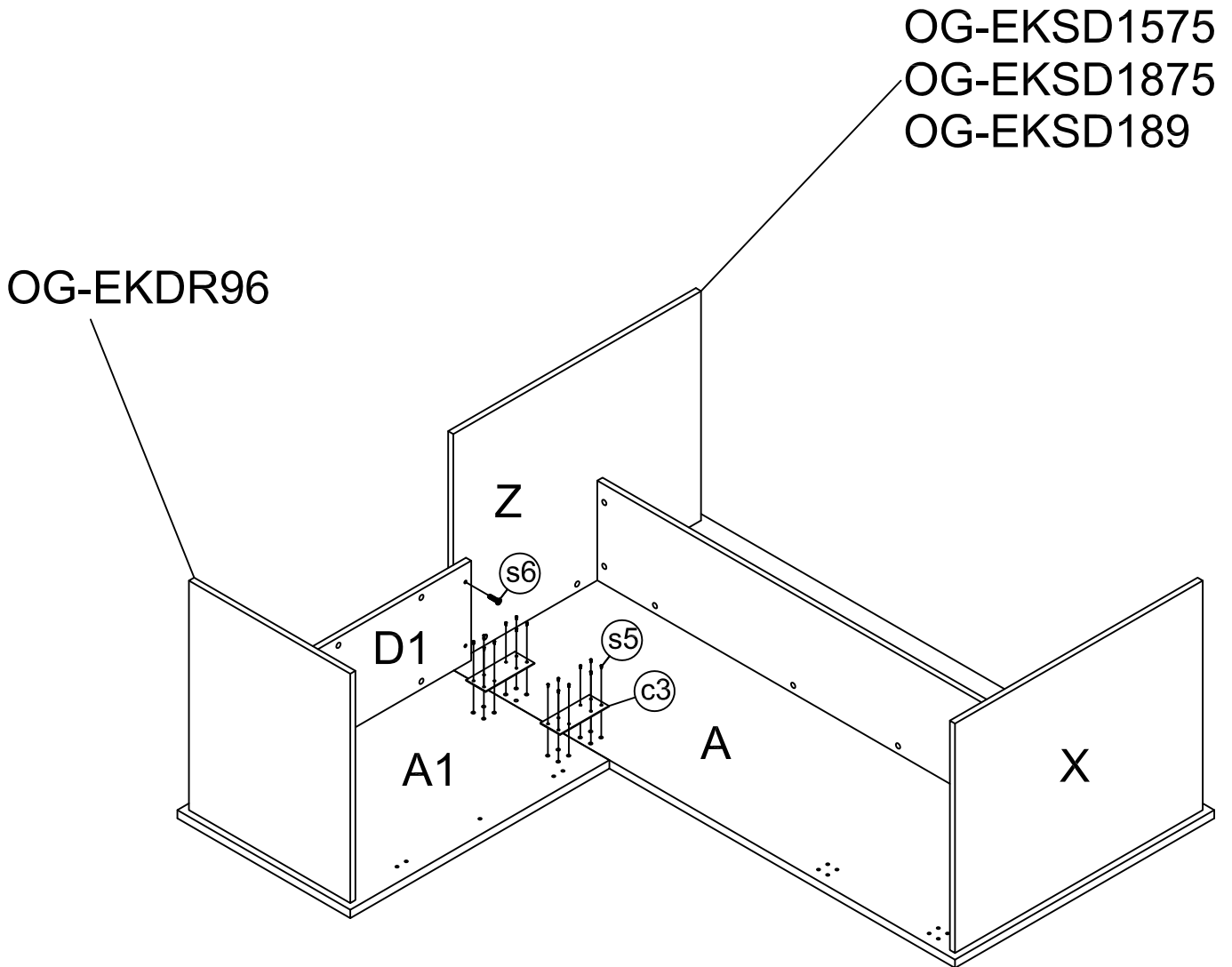

Preparation for Panels A and A1 .

1. Attach the connectors (C3) to panels A and A1 with screws (S5) and tighten in a clockwise direction as illustrated above.
2. Connect the panel D1 and X/Z with the bolts (S6) as illustrated above.

You have now successfully completed the assembly on item:

Cupboard

ITEM NO. : OG-EKDR96

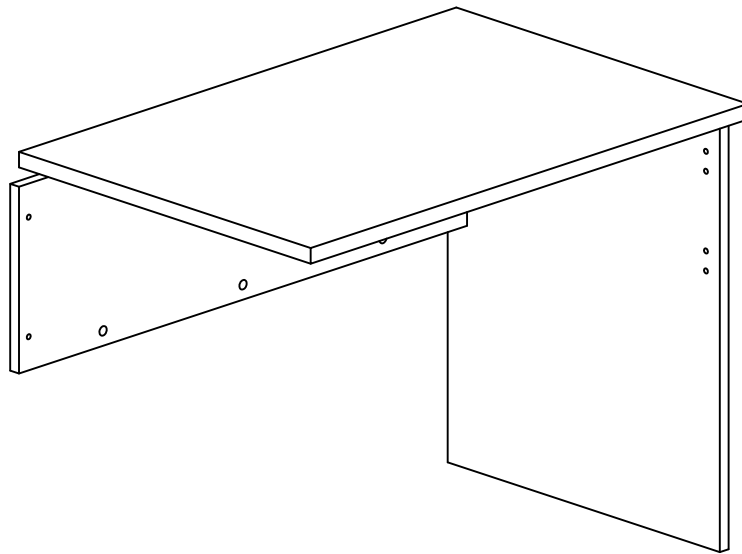

ASSEMBLY INSTRUCTION

ITEM No.:OG-EKMT9
OG-EKMT12

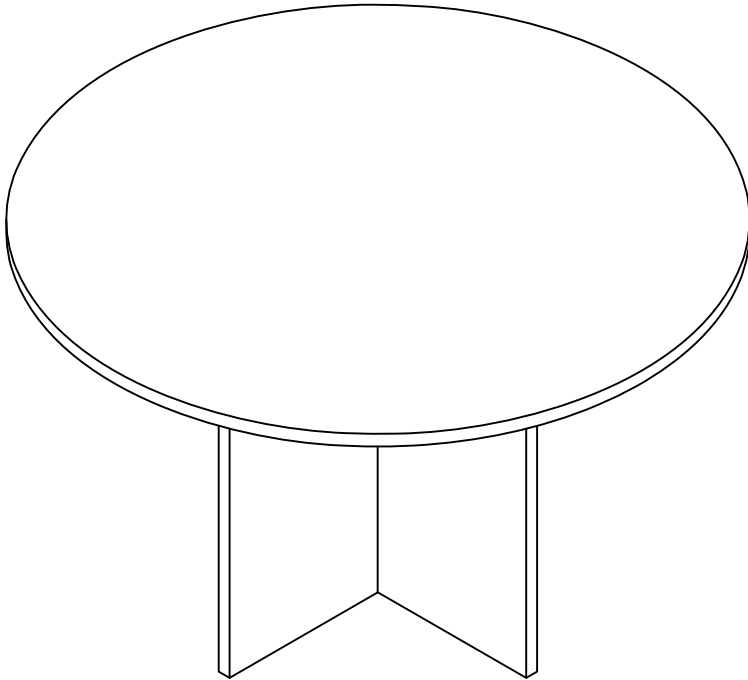

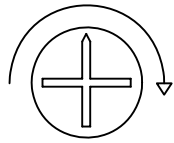

The turning direction of attaching



The arrow direction=front

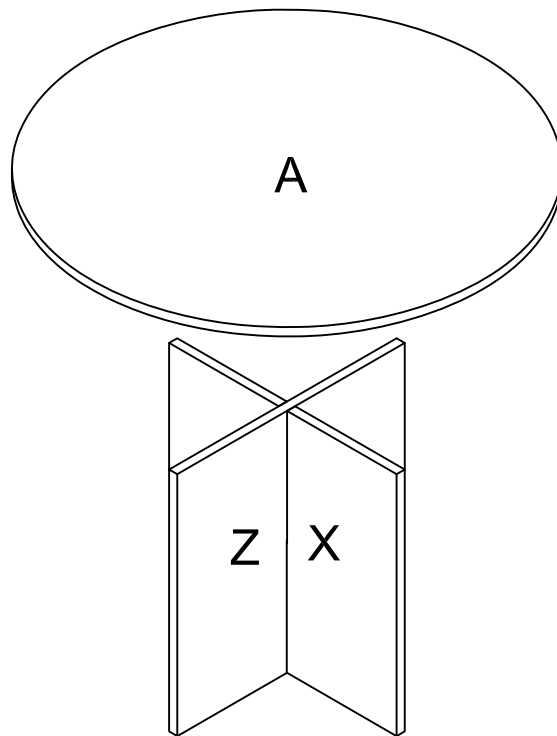

PARTS LIST

ITEM	DESCRIPTION	QTY.	ITEM	DESCRIPTION	QTY.
A	Top panel	1	Ⓒ1	($\frac{5}{8}$ ") Cam Cover	8
X	Left side panel	1			
Z	Right side panel	1			

Pre-installed parts

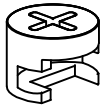

Ⓒ5 Cam



Ⓒ1 ($\frac{5}{8}$ ") Cam Cover-8

STEP 1

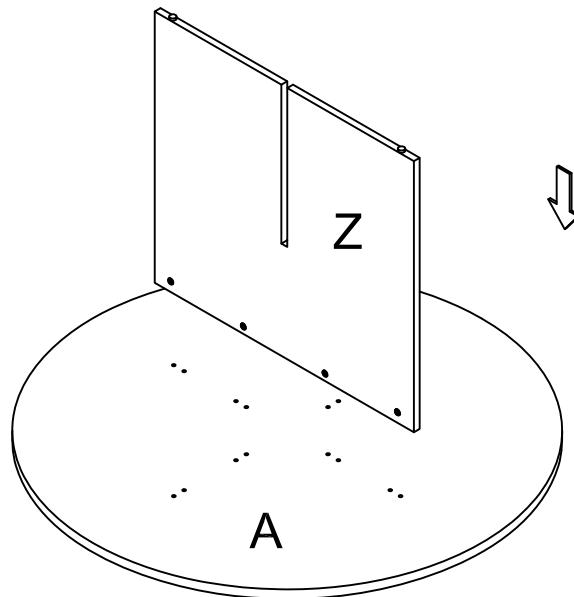

Preparation for Panels A and Z.

1. Connect Cam bolts and dowels on panel Z to the holes on panel A and tighten in a clockwise direction as illustrated above.

STEP 2

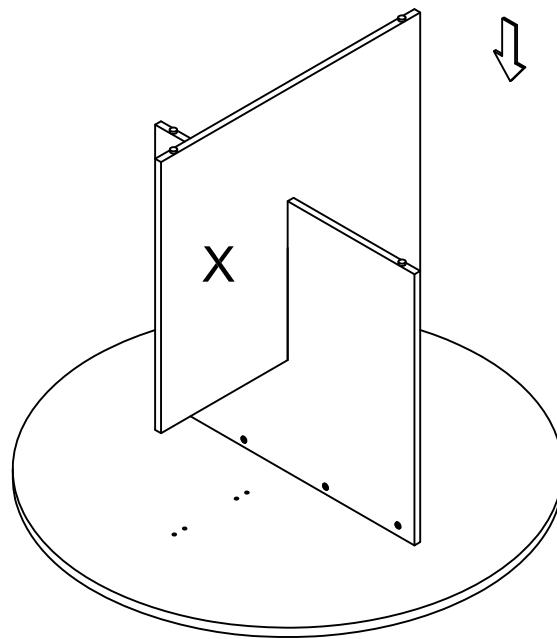

Preparation for Panels X.

1. Connect Cam bolts and dowels on panel X to the holes on panel A and tighten in a clockwise direction as illustrated above.

You have now successfully completed
the assembly on item:

ITEM No.:OG-EKMT9
OG-EKMT12

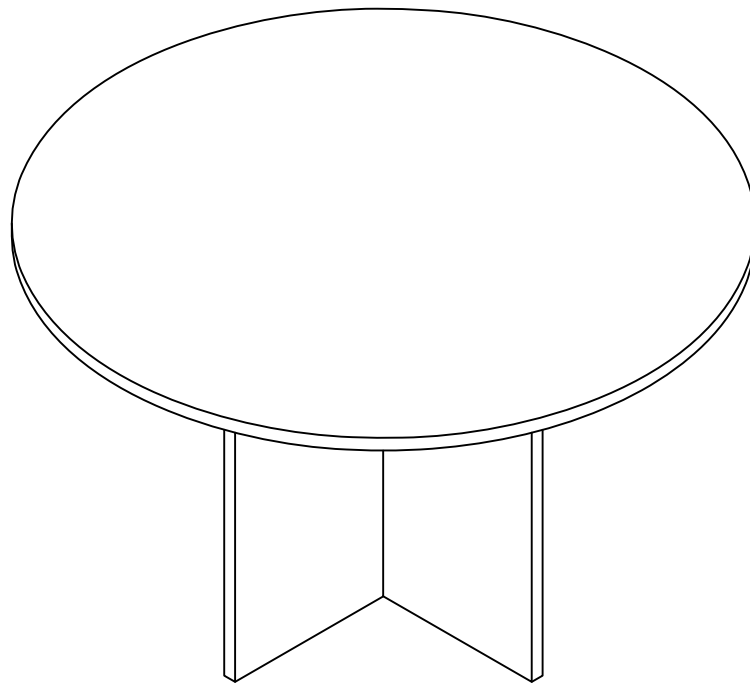

ASSEMBLY INSTRUCTION

Cupboard

ITEM NO. : OG-EKMT189D

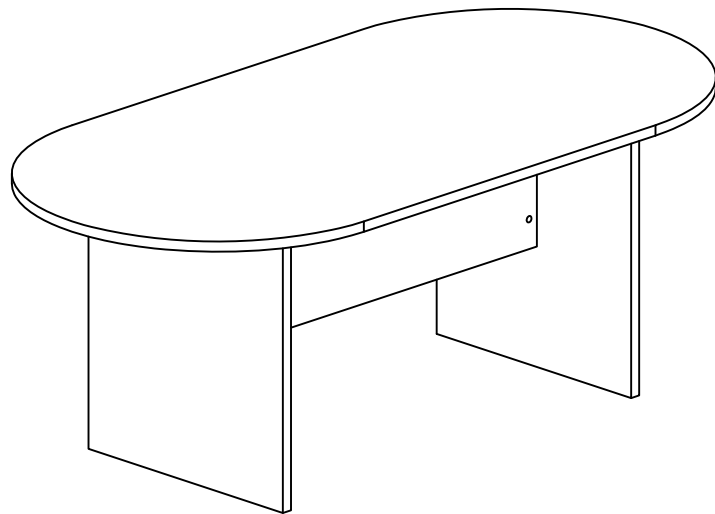

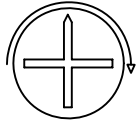

The turning direction of attaching



The arrow direction=front

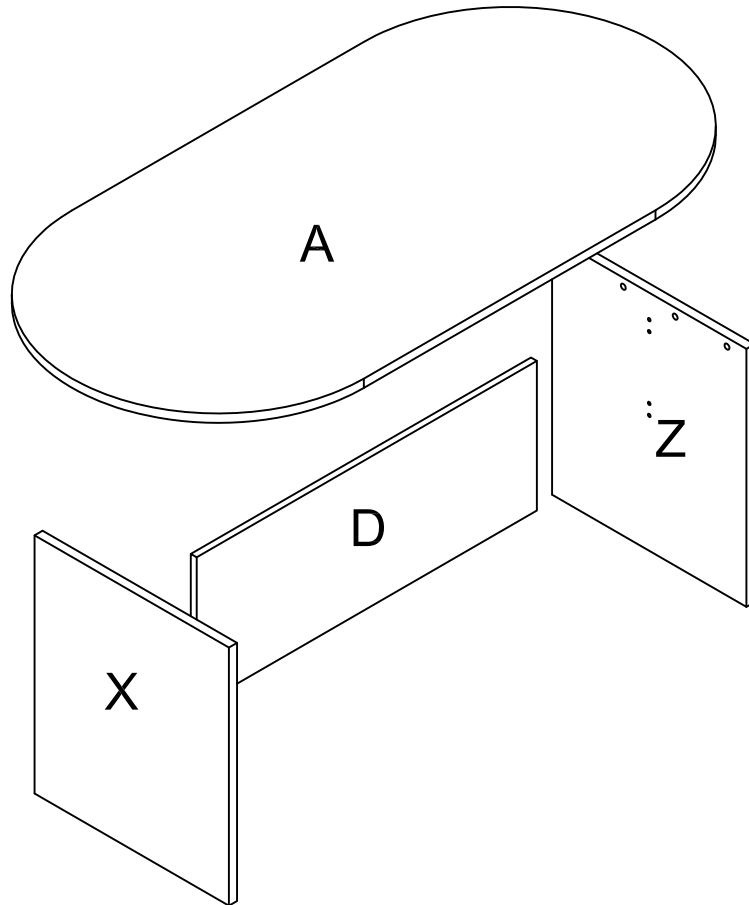

PARTS LIST

ITEM	DESCRIPTION	QTY.	ITEM	DESCRIPTION	QTY.
A	Top panel	1	Ⓒ2	($\frac{5}{8}$ ") Cam Cover	25
X	Left side panel	1	Ⓔ1	4*16 Screw	38
Z	Right side panel	1	Ⓓ1	Bracket	4
D	Back panel	1			



Ⓒ2 ($\frac{5}{8}$ ") Cam Cover-16



Ⓔ1 4*16 Screw-16



Ⓓ1 Bracket-4

Pre-installed parts

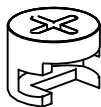

Ⓒ5 Cam

STEP 1

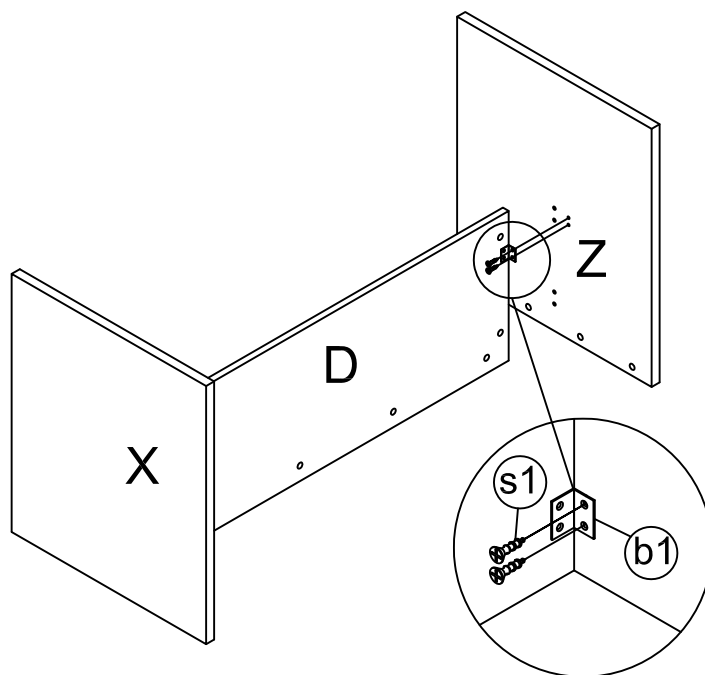

Preparation for Panels X, Z and D.

1. Connect Cam bolts and dowels on panel D to the holes on panel X and Z and tighten in a clockwise direction as illustrated above.
2. Fix Bracket (b1) to panels X,Z and D with fix bolts (s1) as illustrated above.

STEP 2

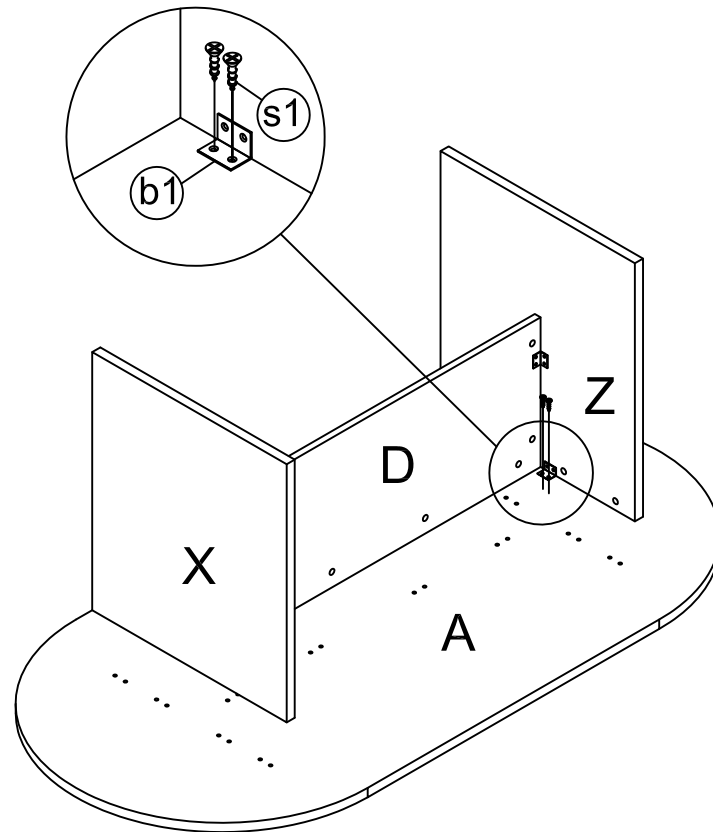

Preparation for Panels A.

1. Connect Cam bolts and dowels on panel X,Z and D to the holes on panel A and tighten in a clockwise direction as illustrated above.
2. Fix Bracket (b1) to panels X,Z and A with fix bolts (s1) as illustrated above.

You have now successfully completed the assembly on item:

Cupboard

ITEM NO. : OG-EKMT189D

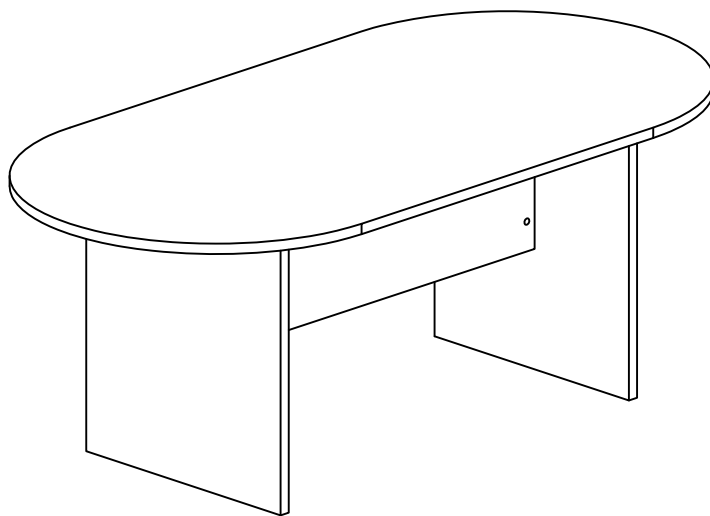

ASSEMBLY INSTRUCTION

Cupboard

ITEM NO. : OG-EKMT2412D

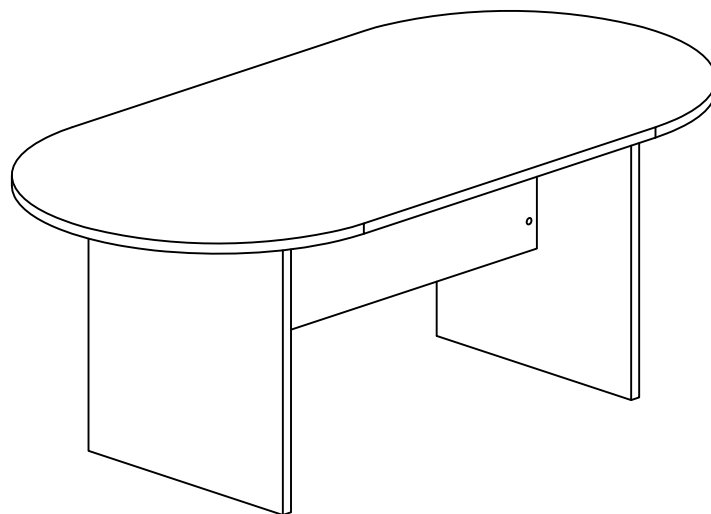

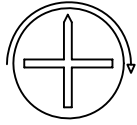

The turning direction of attaching



The arrow direction=front

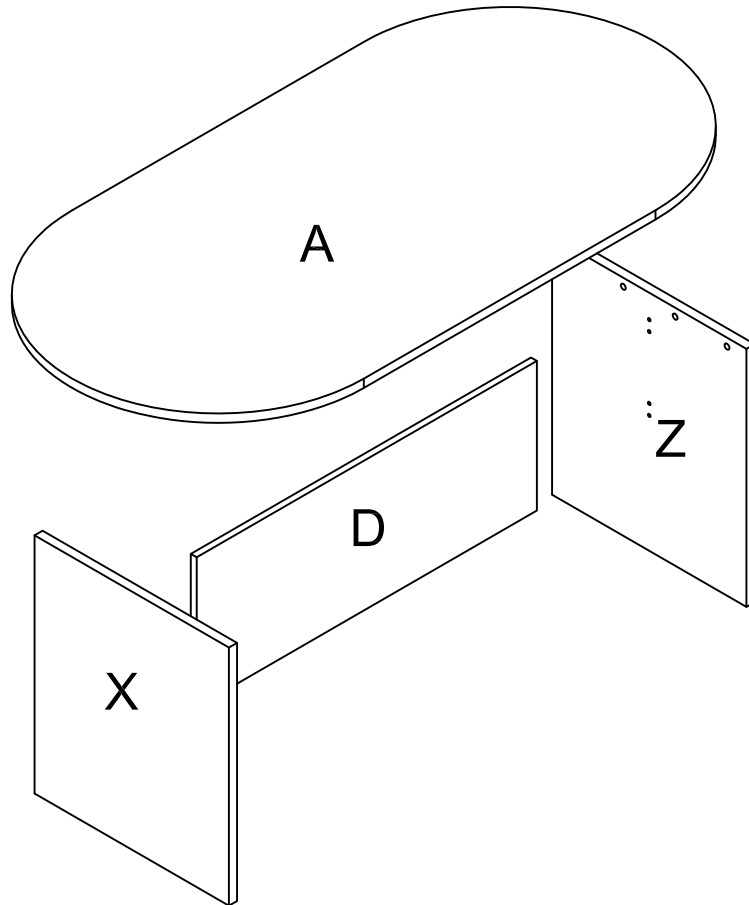

PARTS LIST

ITEM	DESCRIPTION	QTY.	ITEM	DESCRIPTION	QTY.
A	Top panel	1	Ⓒ2	($\frac{5}{8}$ ") Cam Cover	25
X	Left side panel	1	Ⓔ1	4*16 Screw	38
Z	Right side panel	1	Ⓓ1	Bracket	4
D	Back panel	1			



Ⓒ2 ($\frac{5}{8}$ ") Cam Cover-16



Ⓔ1 4*16 Screw-16



Ⓓ1 Bracket-4

Pre-installed parts

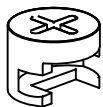

Ⓒ5 Cam

STEP 1

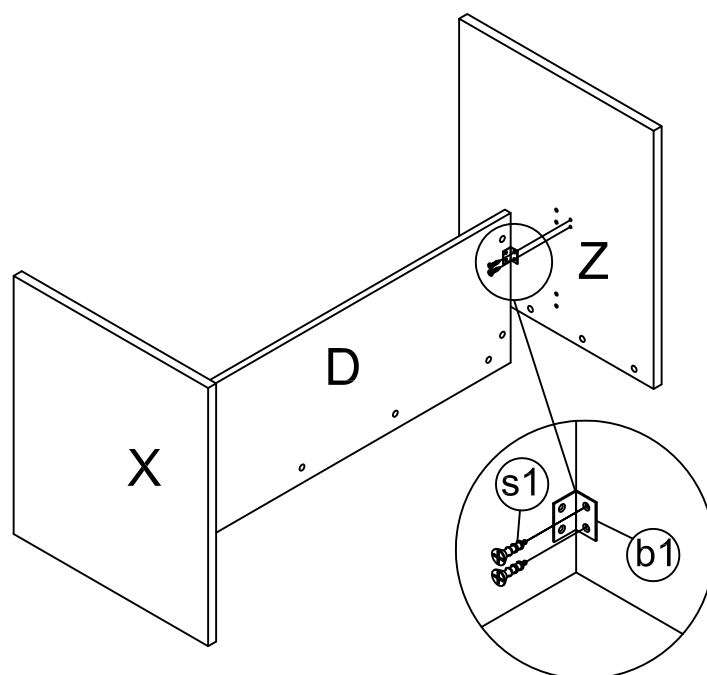

Preparation for Panels X, Z and D.

1. Connect Cam bolts and dowels on panel D to the holes on panel X and Z and tighten in a clockwise direction as illustrated above.
2. Fix Bracket (b1) to panels X,Z and D with fix bolts (s1) as illustrated above.

STEP 2

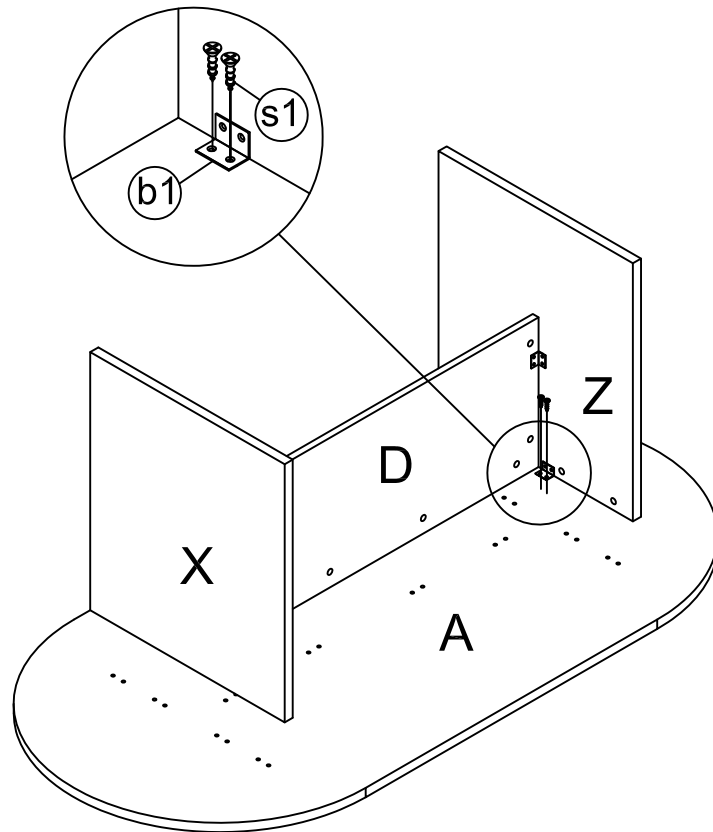

Preparation for Panels A.

1. Connect Cam bolts and dowels on panel X,Z and D to the holes on panel A and tighten in a clockwise direction as illustrated above.
2. Fix Bracket (b1) to panels X,Z and A with fix bolts (s1) as illustrated above.

You have now successfully completed the assembly on item:

Cupboard

ITEM NO. : OG-EKMT2412D

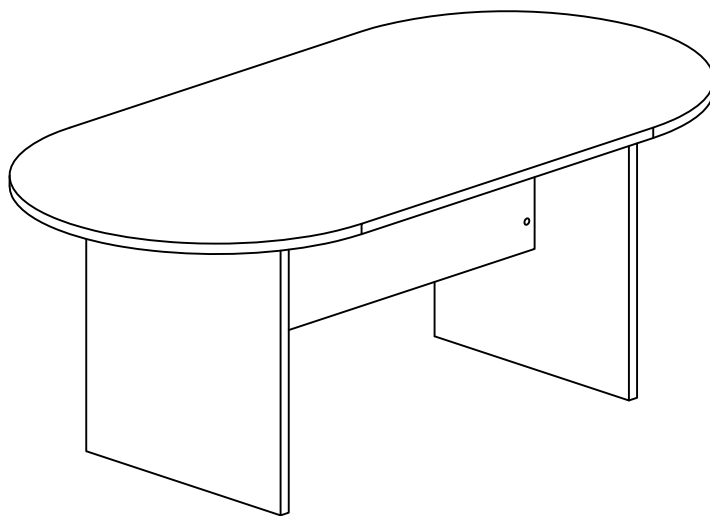

ASSEMBLY INSTRUCTION

Cupboard

ITEM NO. : OG-EKSD126

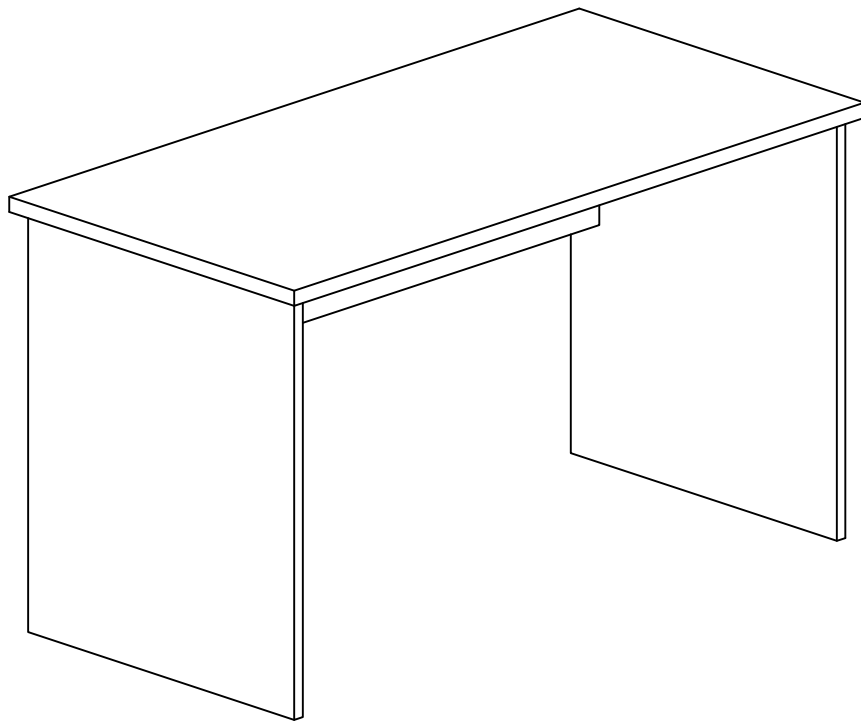

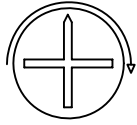

The turning direction of attaching



The arrow direction=front

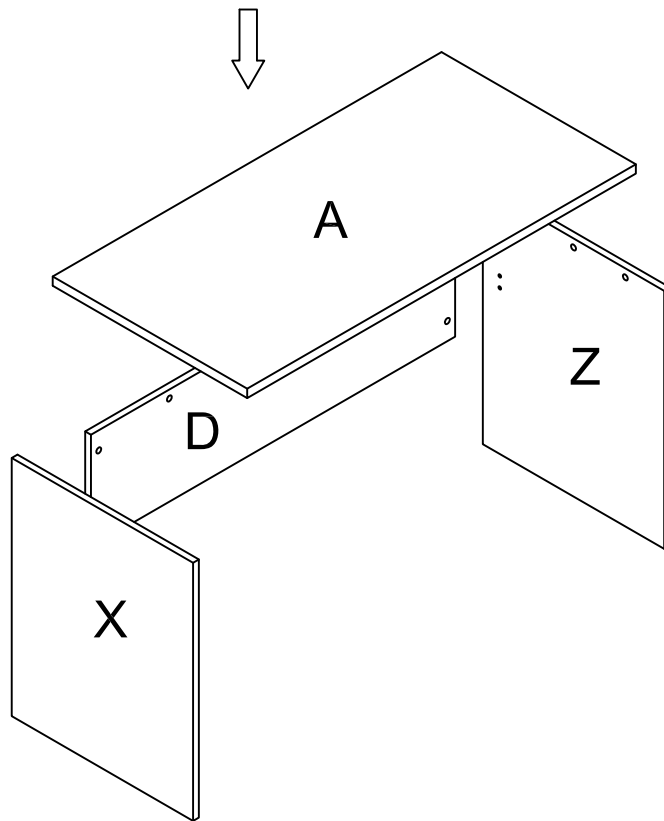

PARTS LIST

ITEM	DESCRIPTION	QTY.	ITEM	DESCRIPTION	QTY.
A	Top panel	1	Ⓒ2	($\frac{5}{8}$ ") Cam Cover	13
X	Left side panel	1	Ⓔ1	4*16 Screw	16
Z	Right side panel	1	Ⓓ1	Bracket	4
D	Back panel	1			



Ⓒ2 ($\frac{5}{8}$ ") Cam Cover-13



Ⓔ1 4*16 Screw-16



Ⓓ1 Bracket-4

Pre-installed parts

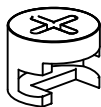

Ⓒ5 Cam

STEP 1

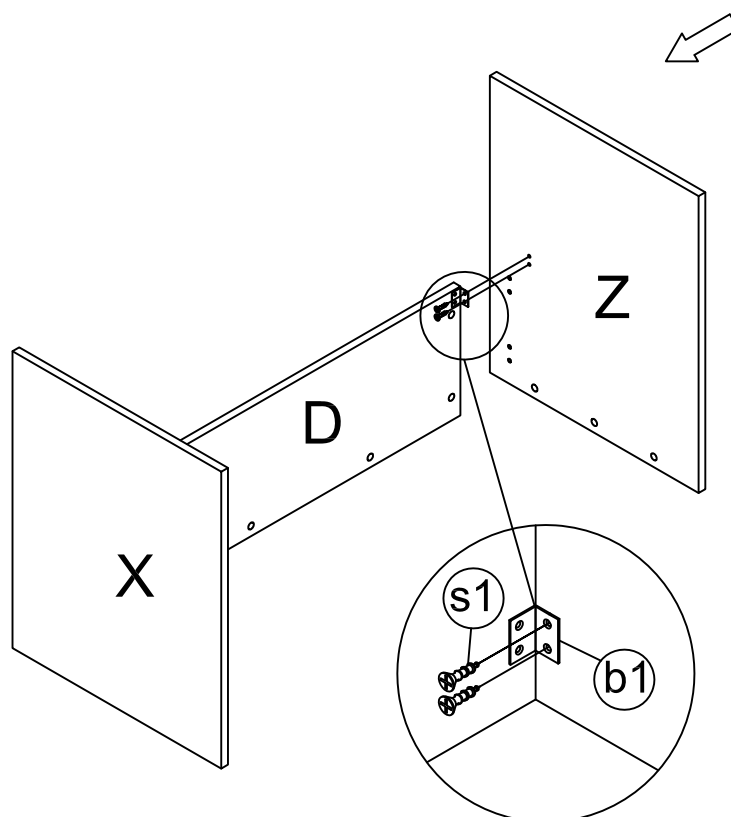

Preparation for Panels X, Z and D.

1. Connect Cam bolts and dowels on panel D to the holes on panel X and Z and tighten in a clockwise direction as illustrated above.
2. Fix Bracket (b1) to panels X,Z and D with fix bolts (s1) as illustrated above.

STEP 2

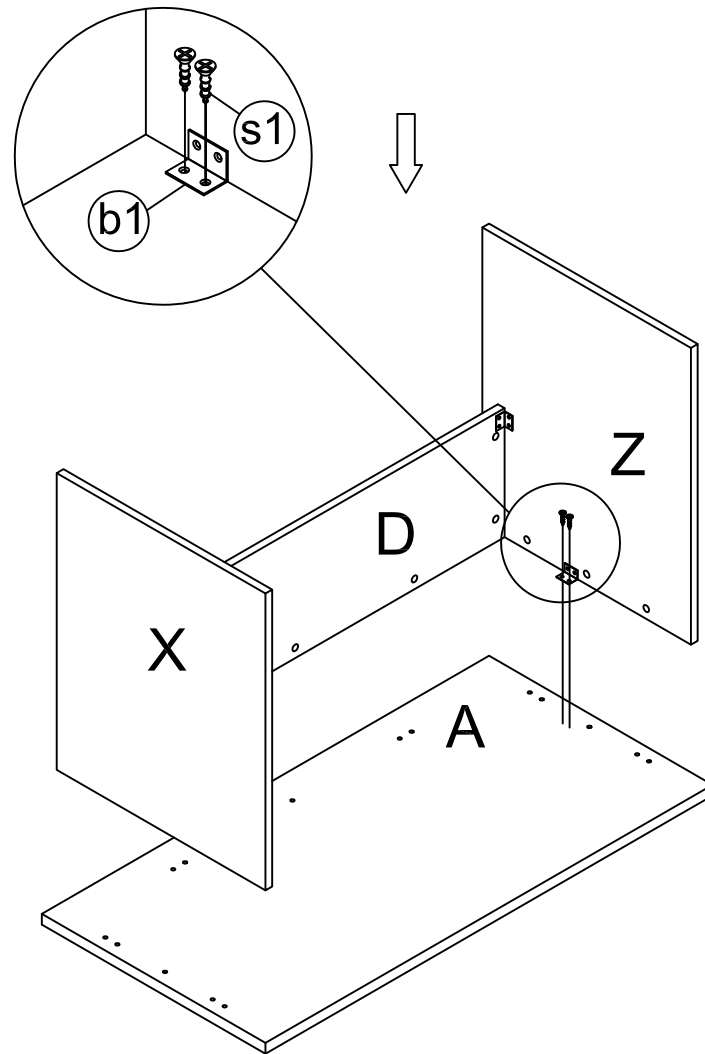

Preparation for Panels A.

1. Connect Cam bolts and dowels on panel X, Z and D to the holes on panel A and tighten in a clockwise direction as illustrated above.
2. Fix Bracket (b1) to panels X, Z and A with fix bolts (s1) as illustrated above.

You have now successfully completed the assembly on item:

Cupboard

ITEM NO. : OG-EKSD126

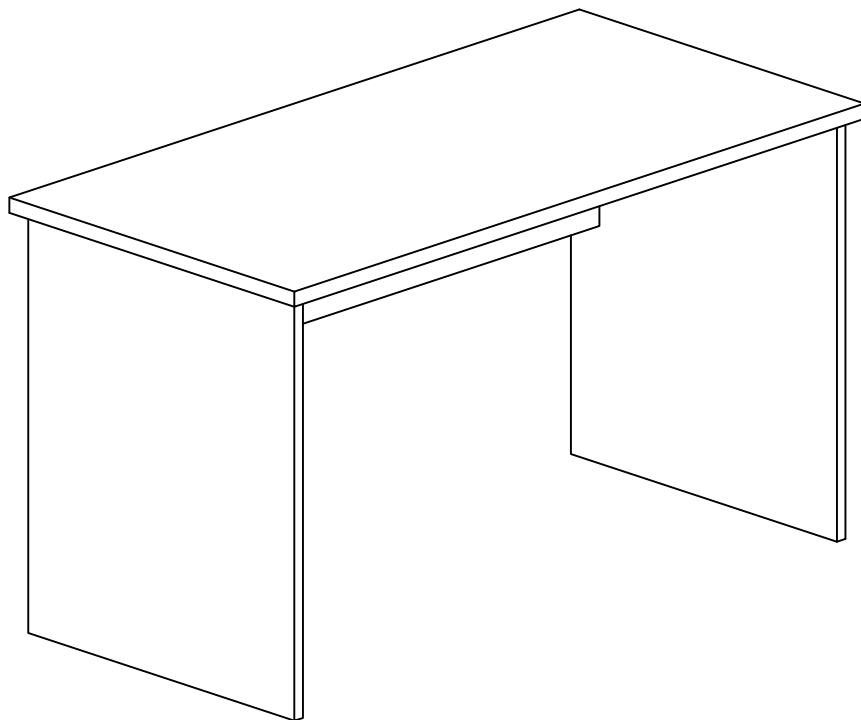

ASSEMBLY INSTRUCTION

Cupboard

ITEM NO. : OG-EKSD189

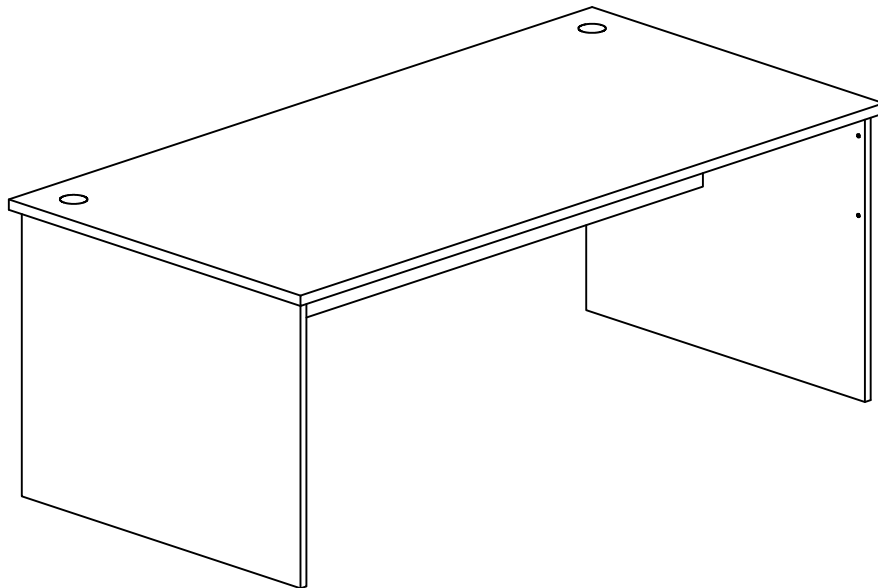

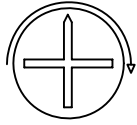

The turning direction of attaching



The arrow direction=front

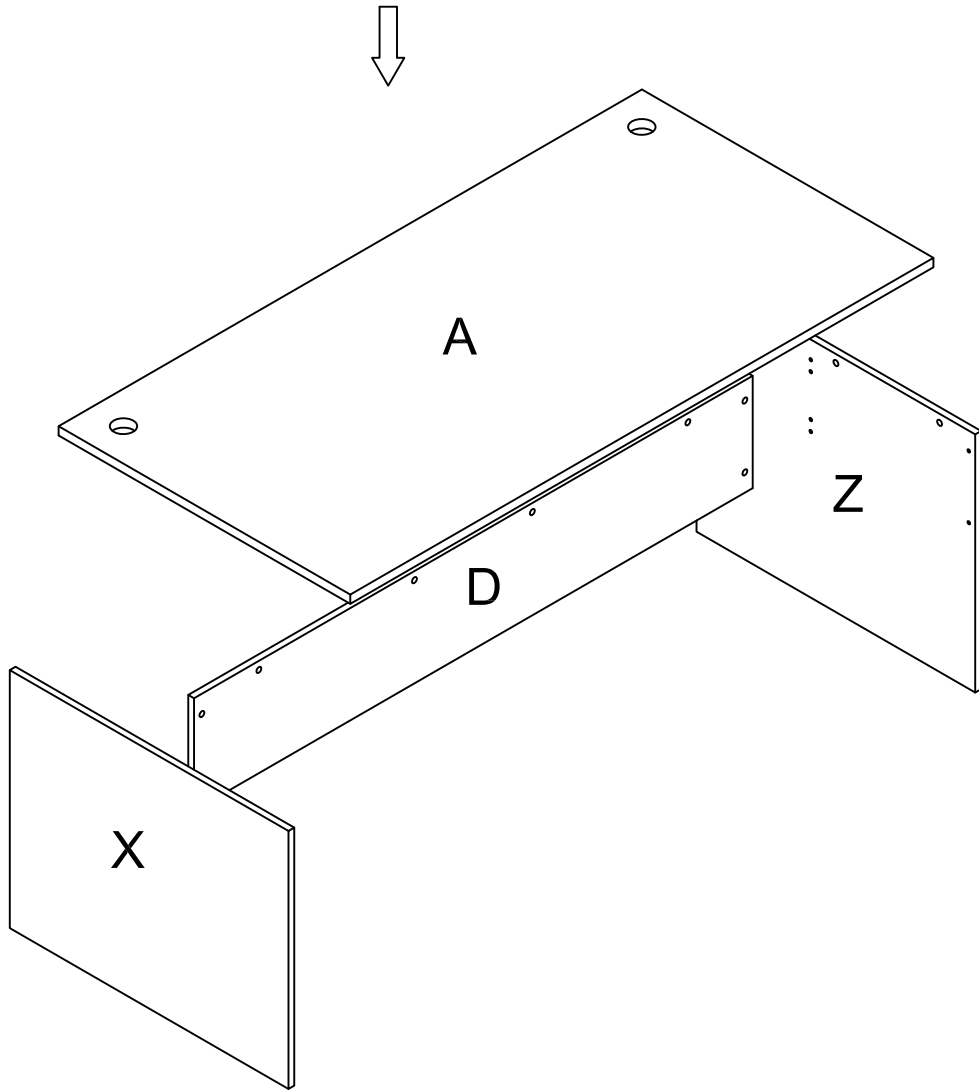

PARTS LIST

ITEM	DESCRIPTION	QTY.	ITEM	DESCRIPTION	QTY.
A	Top panel	1	(c2)	($\frac{5}{8}$ ") Cam Cover	14
X	Left side panel	1	(s1)	4*16 Screw	16
Z	Right side panel	1	(b1)	Bracket	4
D	Back panel	1			



(c2) ($\frac{5}{8}$ ") Cam Cover-14



(s1) 4*16 Screw-16



(b1) Bracket-4

Pre-installed parts

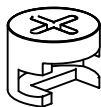

(c5) Cam

STEP 1

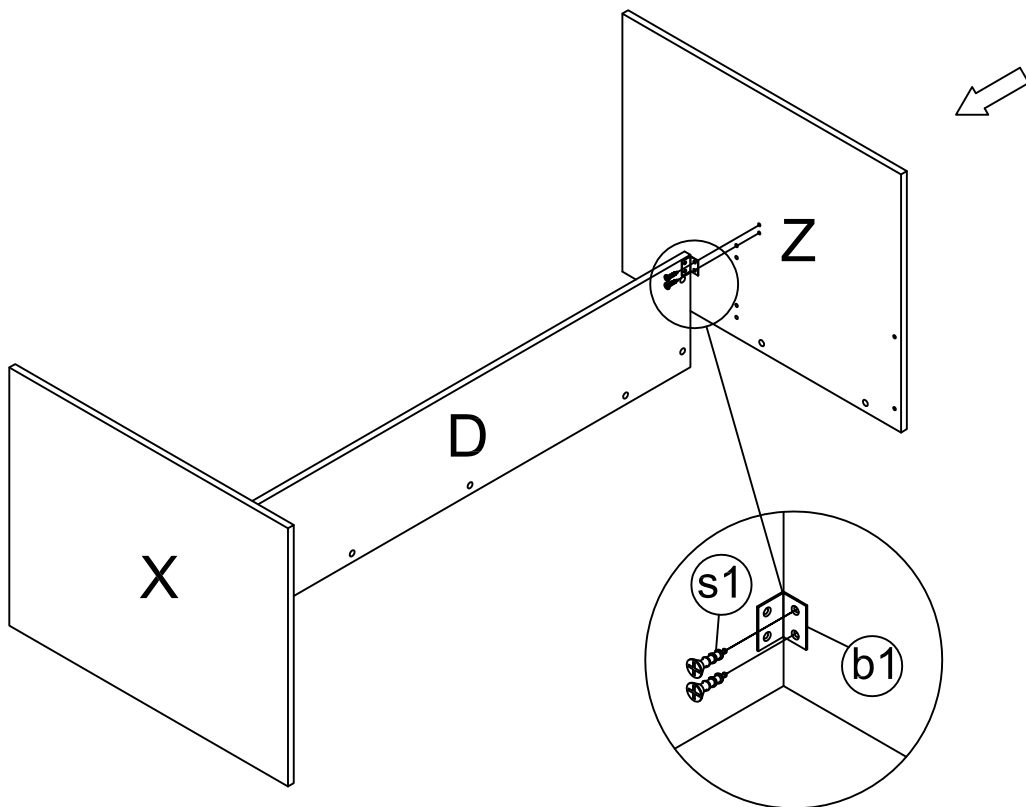

Preparation for Panels X, Z and D.

1. Connect Cam bolts and dowels on panel D to the holes on panel X and Z and tighten in a clockwise direction as illustrated above.
2. Fix Bracket (b1) to panels X, Z and D with fix bolts (s1) as illustrated above.

STEP 2

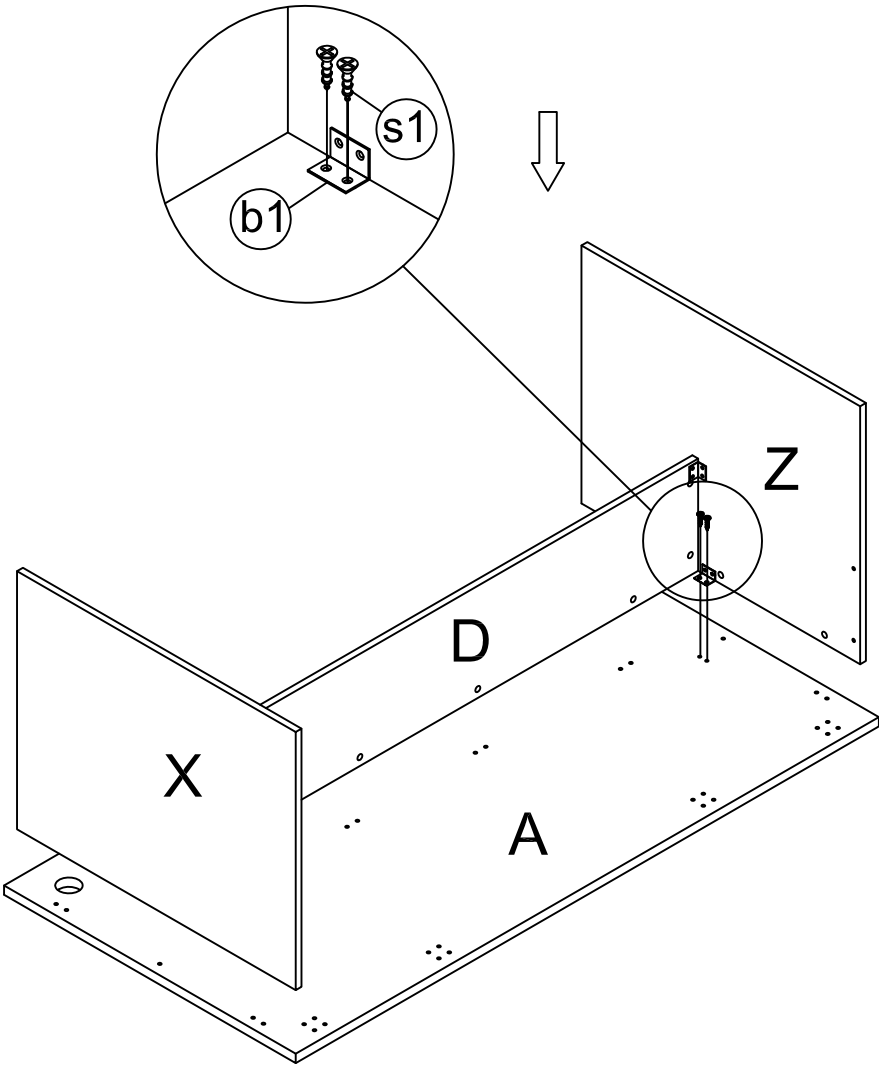

Preparation for Panels A.

- 1. Connect Cam bolts and dowels on panel X,Z and D to the holes on panel A and tighten in a clockwise direction as illustrated above.
- 2. Fix Bracket (b1) to panels X,Z and A with fix bolts (s1) as illustrated above.

You have now successfully completed the assembly on item:

Cupboard

ITEM NO. : OG-EKSD189

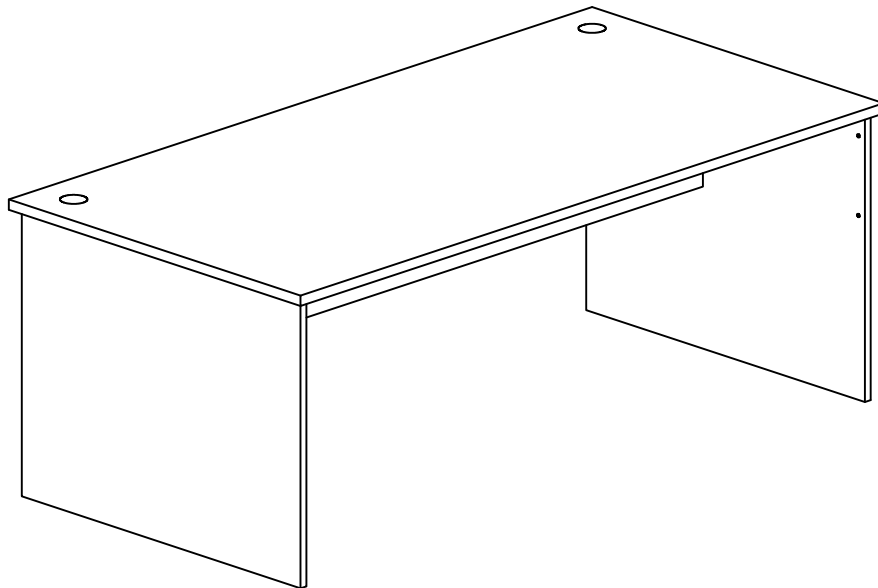

ASSEMBLY INSTRUCTION

Cupboard

ITEM NO. : OG-EKSD1575

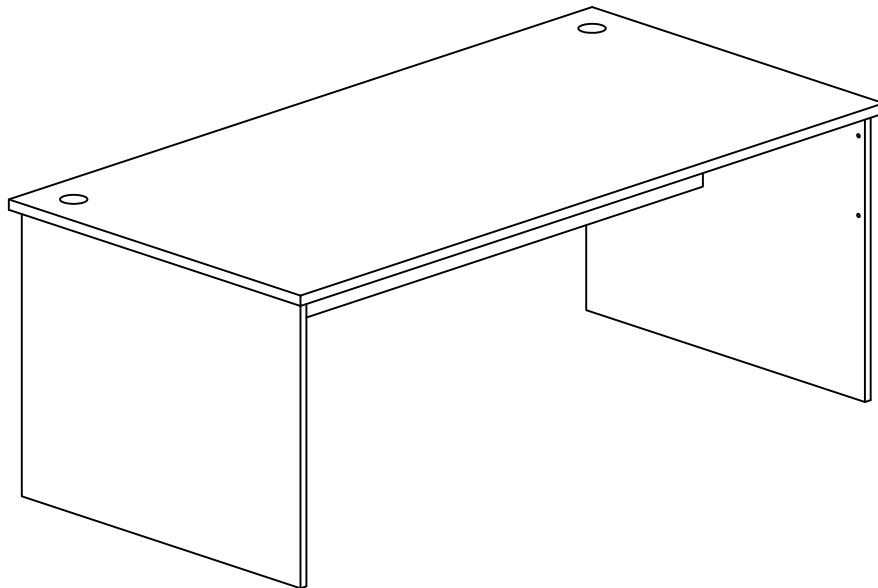

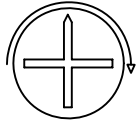

The turning direction of attaching



The arrow direction=front

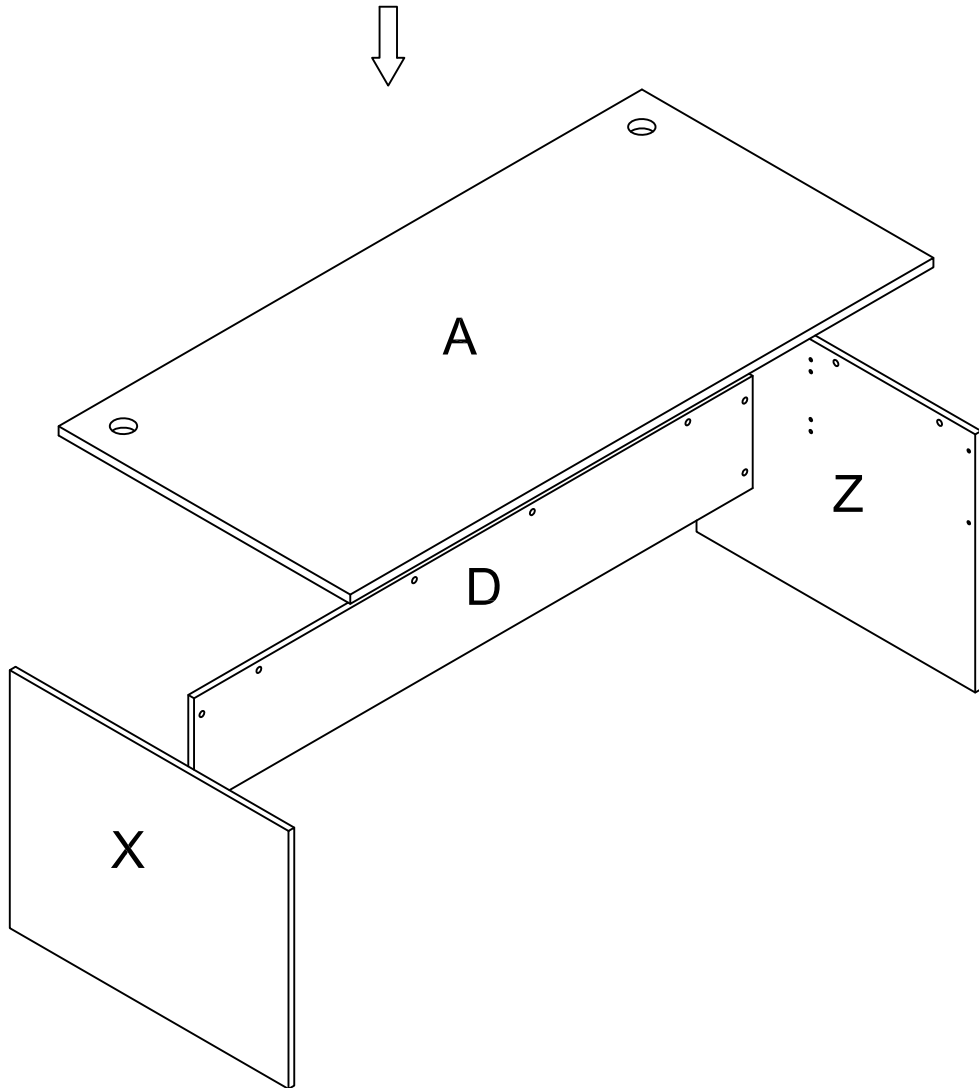

PARTS LIST

ITEM	DESCRIPTION	QTY.	ITEM	DESCRIPTION	QTY.
A	Top panel	1	(c2)	($\frac{5}{8}$ ") Cam Cover	14
X	Left side panel	1	(s1)	4*16 Screw	16
Z	Right side panel	1	(b1)	Bracket	4
D	Back panel	1			



(c2) ($\frac{5}{8}$ ") Cam Cover-14



(s1) 4*16 Screw-16



(b1) Bracket-4

Pre-installed parts

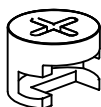

(c5) Cam

STEP 1

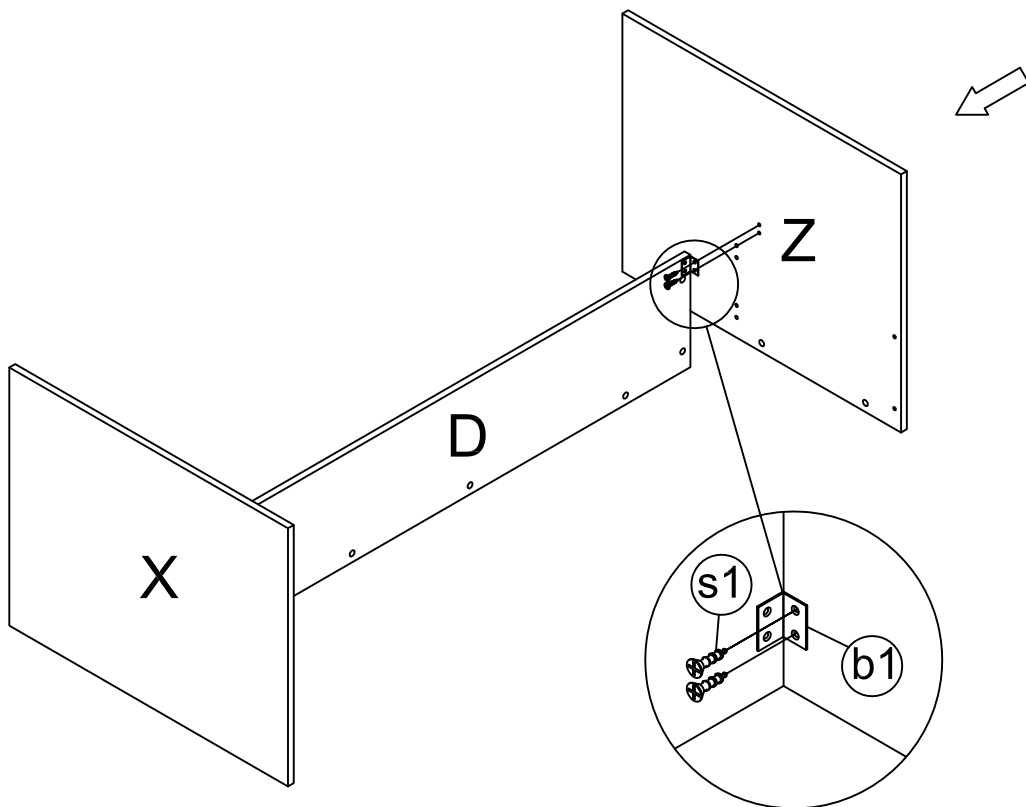

Preparation for Panels X, Z and D.

1. Connect Cam bolts and dowels on panel D to the holes on panel X and Z and tighten in a clockwise direction as illustrated above.
2. Fix Bracket (b1) to panels X, Z and D with fix bolts (s1) as illustrated above.

STEP 2

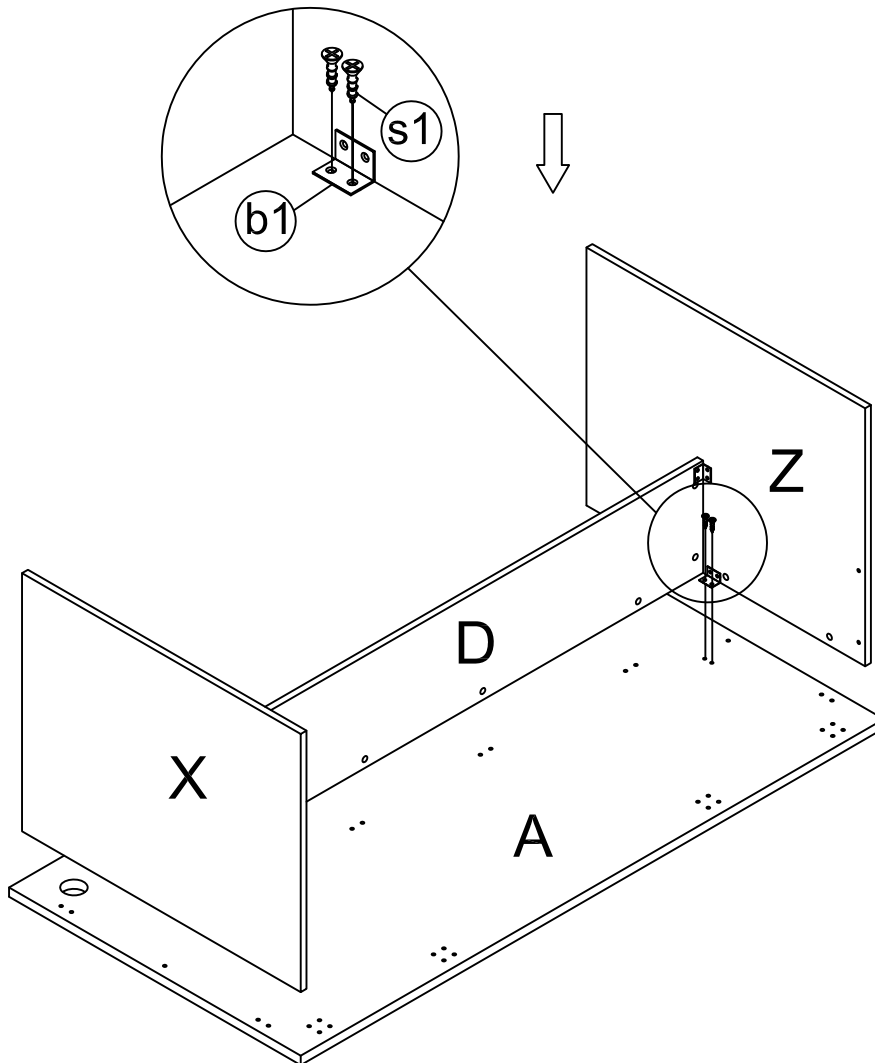

Preparation for Panels A.

1. Connect Cam bolts and dowels on panel X,Z and D to the holes on panel A and tighten in a clockwise direction as illustrated above.
2. Fix Bracket (b1) to panels X,Z and A with fix bolts (s1) as illustrated above.

You have now successfully completed the assembly on item:

Cupboard

ITEM NO. : OG-EKSD1575

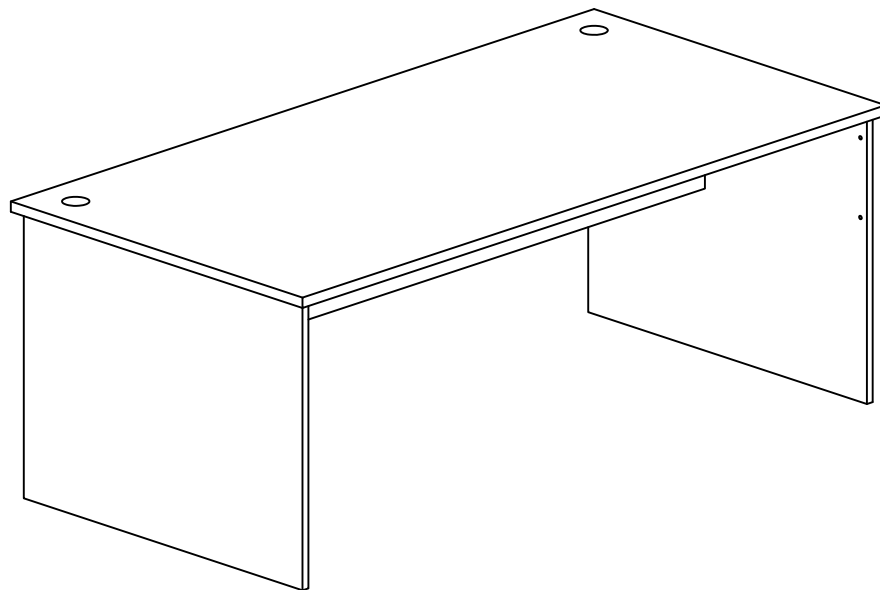

ASSEMBLY INSTRUCTION

Cupboard

ITEM NO. : OG-EKSD1875

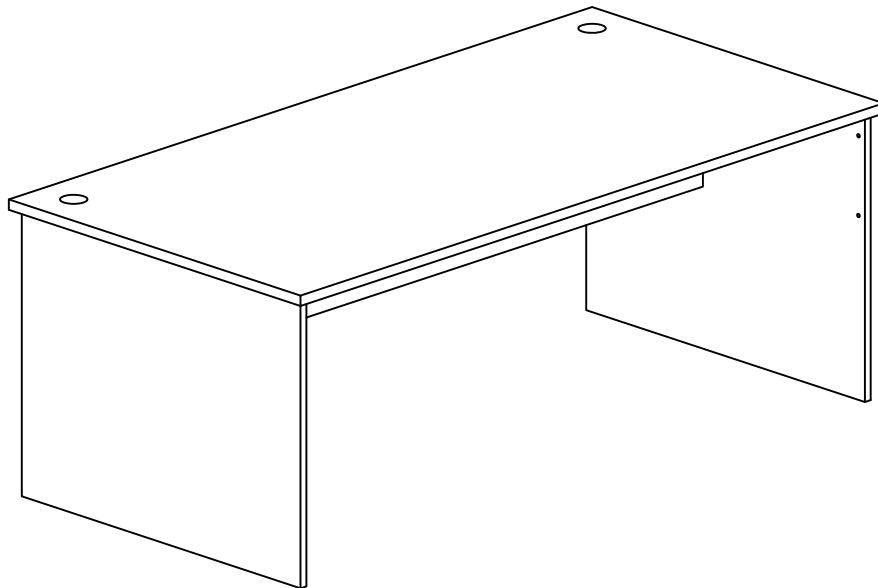

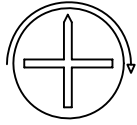

The turning direction of attaching



The arrow direction=front

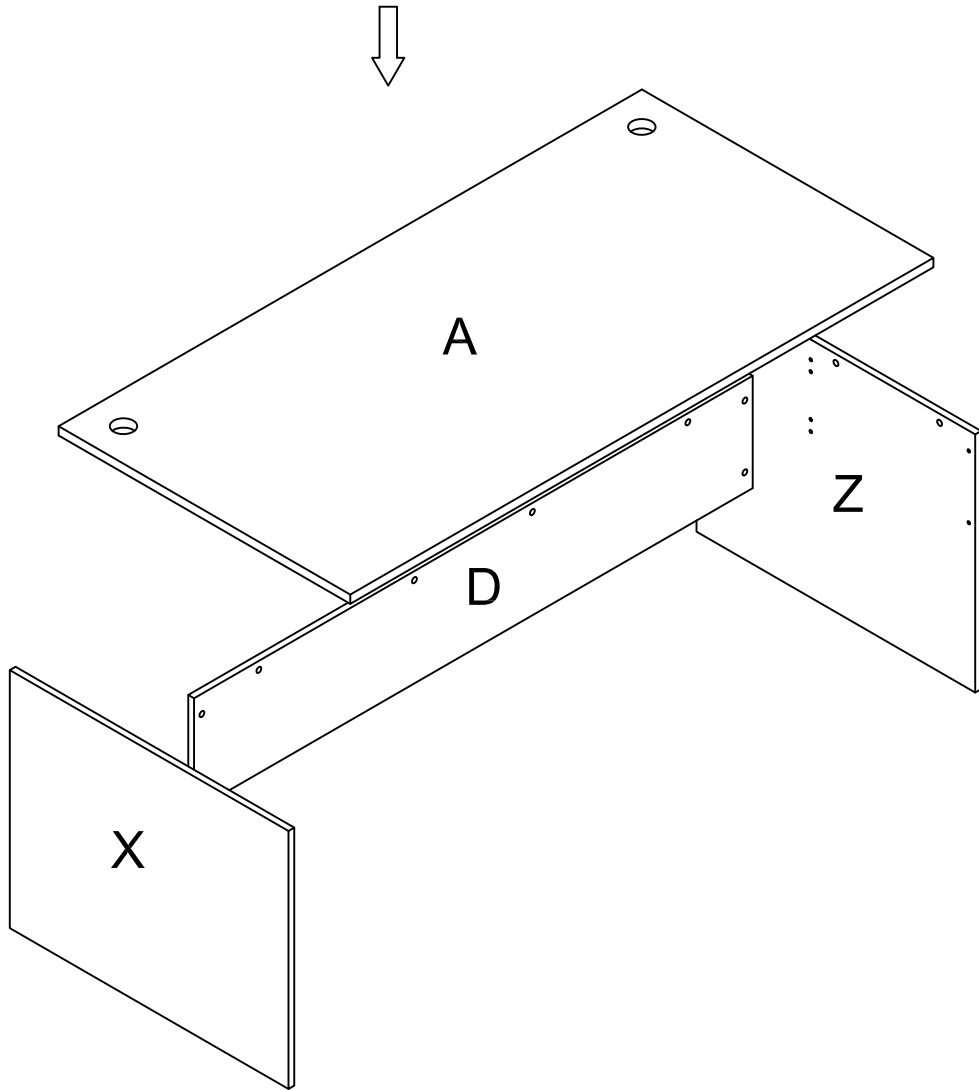

PARTS LIST

ITEM	DESCRIPTION	QTY.	ITEM	DESCRIPTION	QTY.
A	Top panel	1	Ⓒ2	($\frac{5}{8}$ ") Cam Cover	14
X	Left side panel	1	Ⓔ1	4*16 Screw	16
Z	Right side panel	1	Ⓓ1	Bracket	4
D	Back panel	1			



Ⓒ2 ($\frac{5}{8}$ ") Cam Cover-14



Ⓔ1 4*16 Screw-16



Ⓓ1 Bracket-4

Pre-installed parts

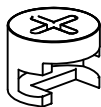

Ⓒ5 Cam

STEP 1

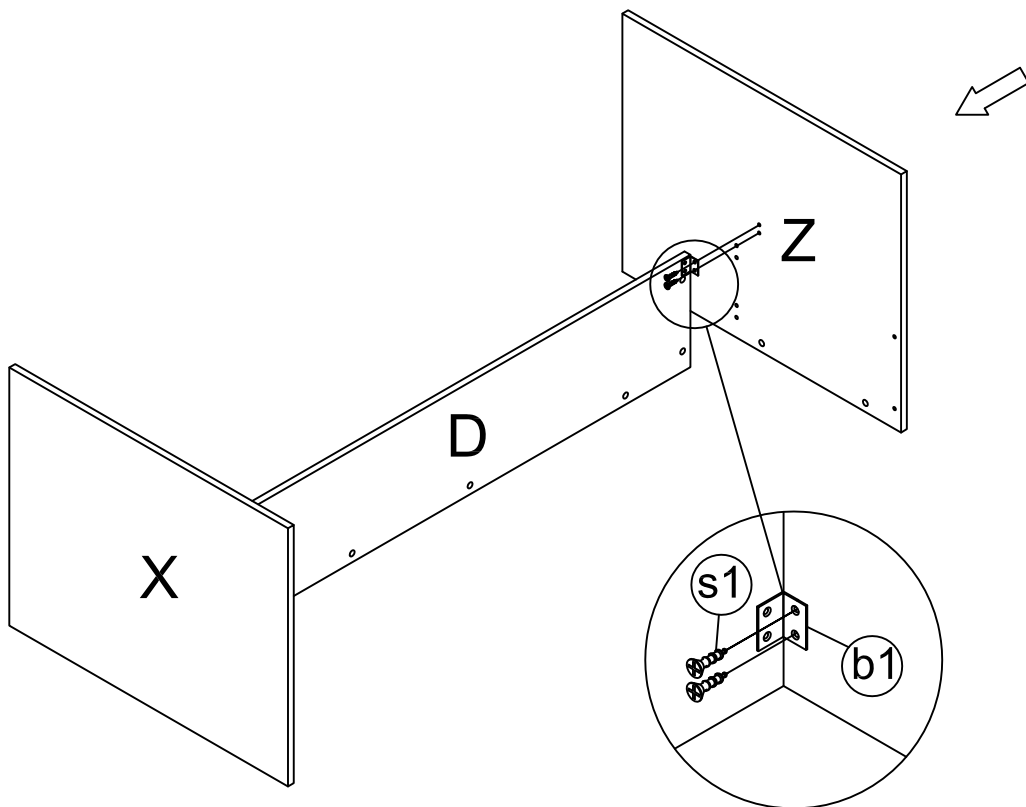

Preparation for Panels X, Z and D.

1. Connect Cam bolts and dowels on panel D to the holes on panel X and Z and tighten in a clockwise direction as illustrated above.
2. Fix Bracket (b1) to panels X, Z and D with fix bolts (s1) as illustrated above.

STEP 2

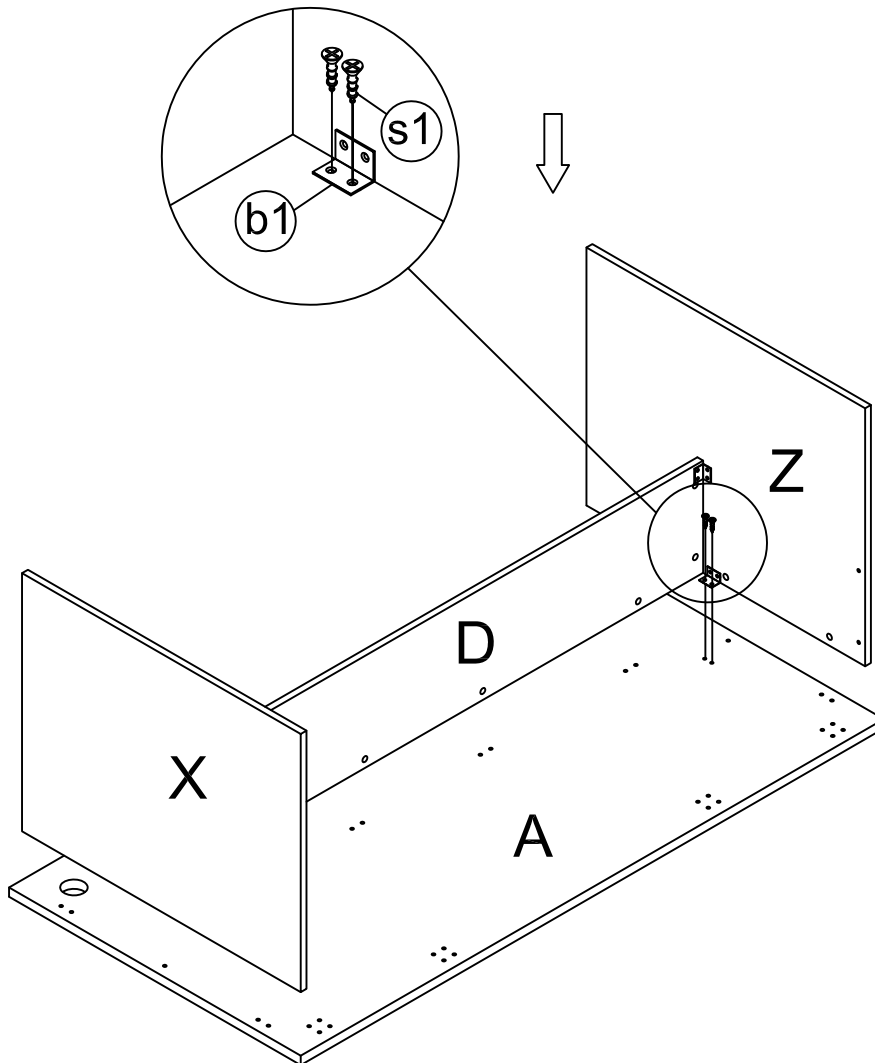

Preparation for Panels A.

1. Connect Cam bolts and dowels on panel X,Z and D to the holes on panel A and tighten in a clockwise direction as illustrated above.
2. Fix Bracket (b1) to panels X,Z and A with fix bolts (s1) as illustrated above.

You have now successfully completed the assembly on item:

Cupboard

ITEM NO. : OG-EKSD1875

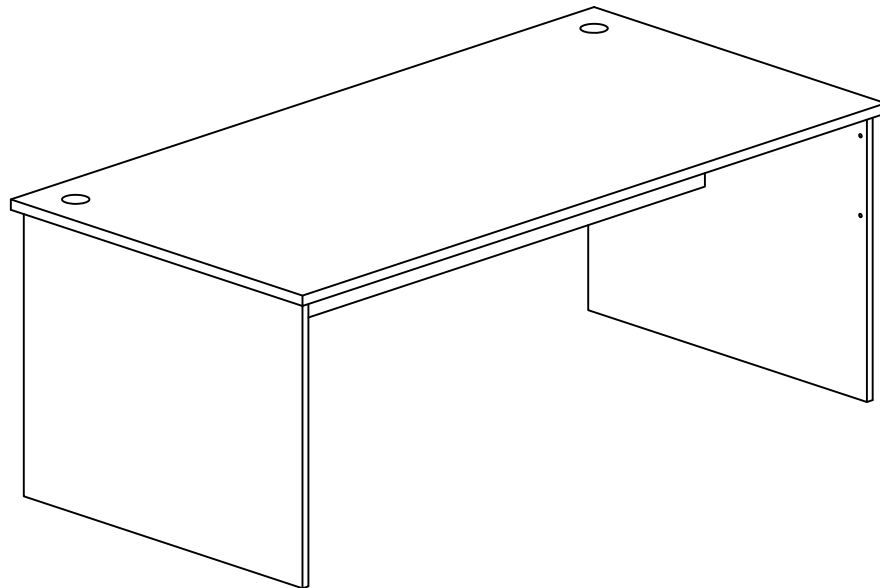

ASSEMBLY INSTRUCTION

Cupboard

ITEM NO. : OG-EKSH

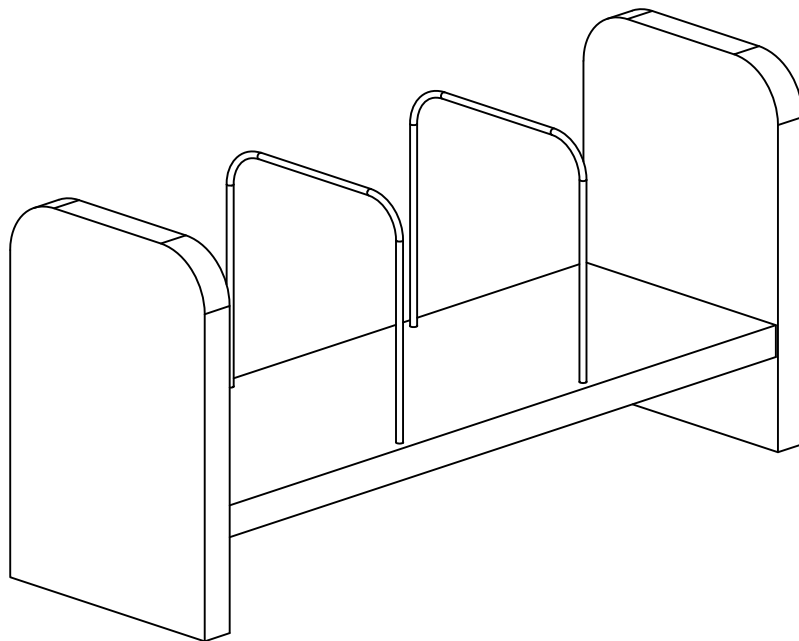

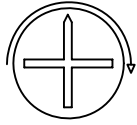

The turning direction of attaching



The arrow direction=front

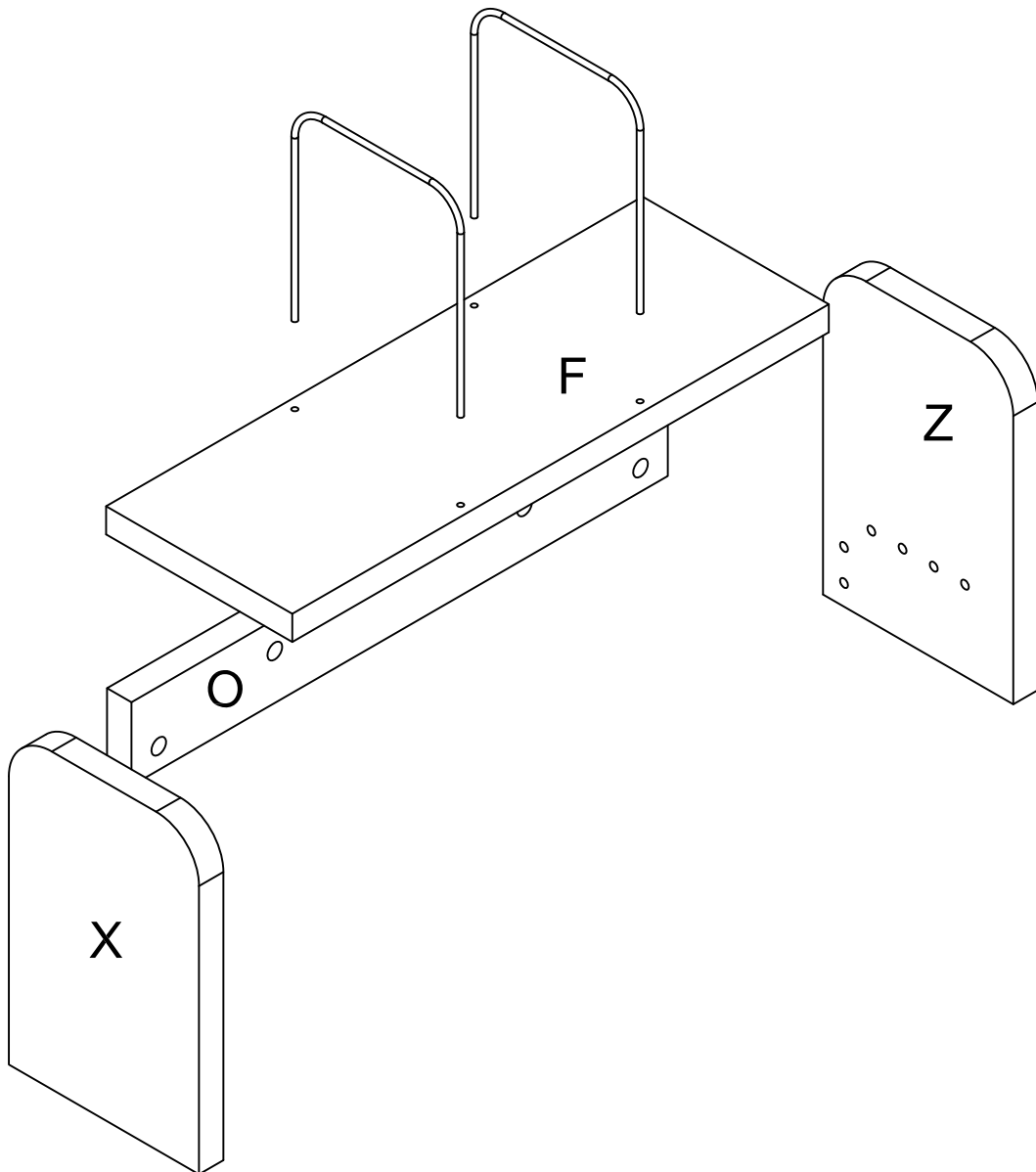

PARTS LIST

ITEM	DESCRIPTION	QTY.	ITEM	DESCRIPTION	QTY.
A	Batten	1	Ⓒ2	($\frac{5}{8}$ ") Cam Cover	8
X	Left side panel	1	Ⓐ1	Anti-slip stickers	5
Z	Right side panel	1	Ⓙ1	The iron bar	2
F	Immovable panel	1			



Ⓒ2 ($\frac{5}{8}$ ") Cam Cover-8



Ⓐ1 Anti-slip stickers-5

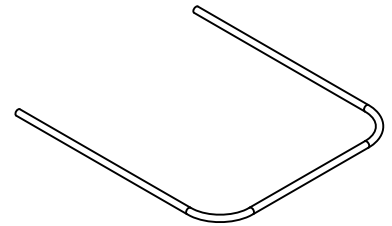

Ⓙ1 The iron bar-2

Pre-installed parts

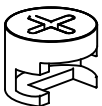

Ⓒ5 Cam

STEP 1

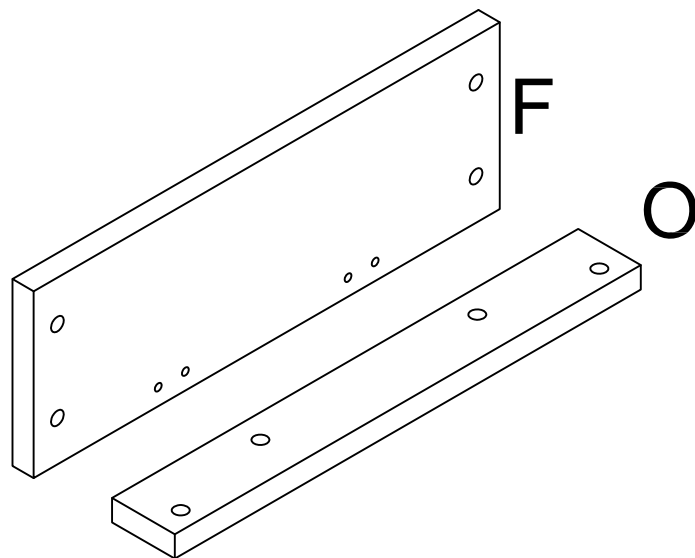

Preparation for Panels F and O.

1. Connect Cam bolts and dowels on panel O to the holes on panel F and tighten in a clockwise direction as illustrated above.

STEP 2

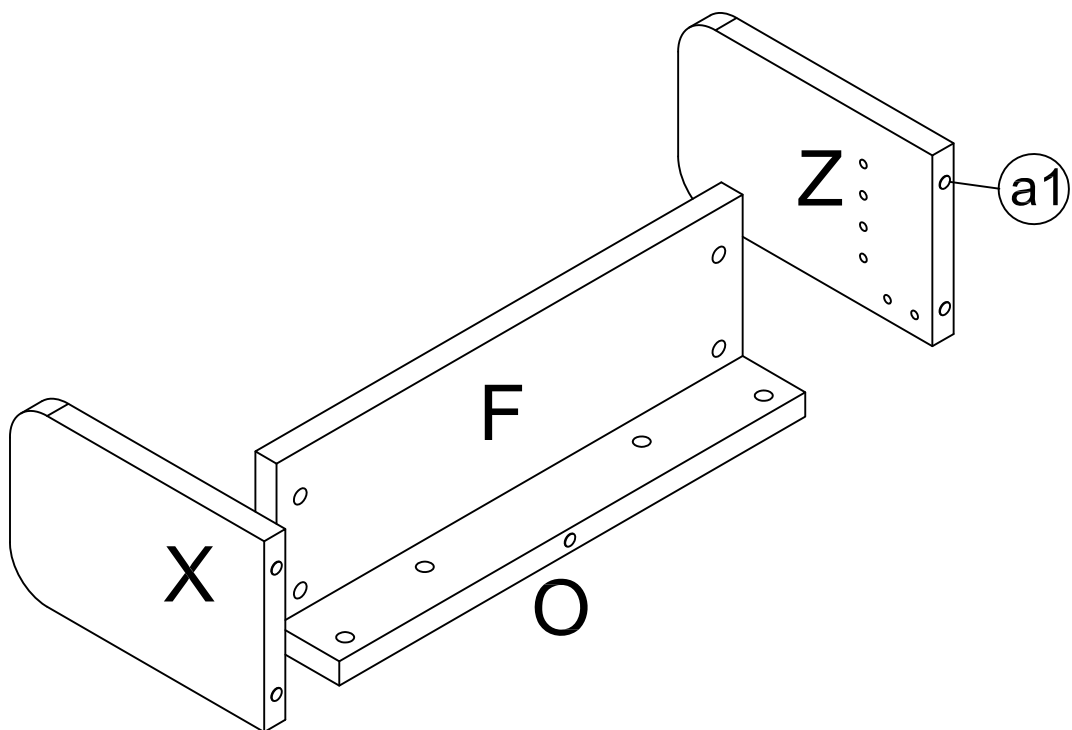

Preparation for Panels X and Z .

1. Connect Cam bolts and dowels on panel F and O to the holes on panel X and Z and tighten in a clockwise direction as illustrated above.
2. (a1) affixed to the X, Z , O board as illustrated above

STEP 3

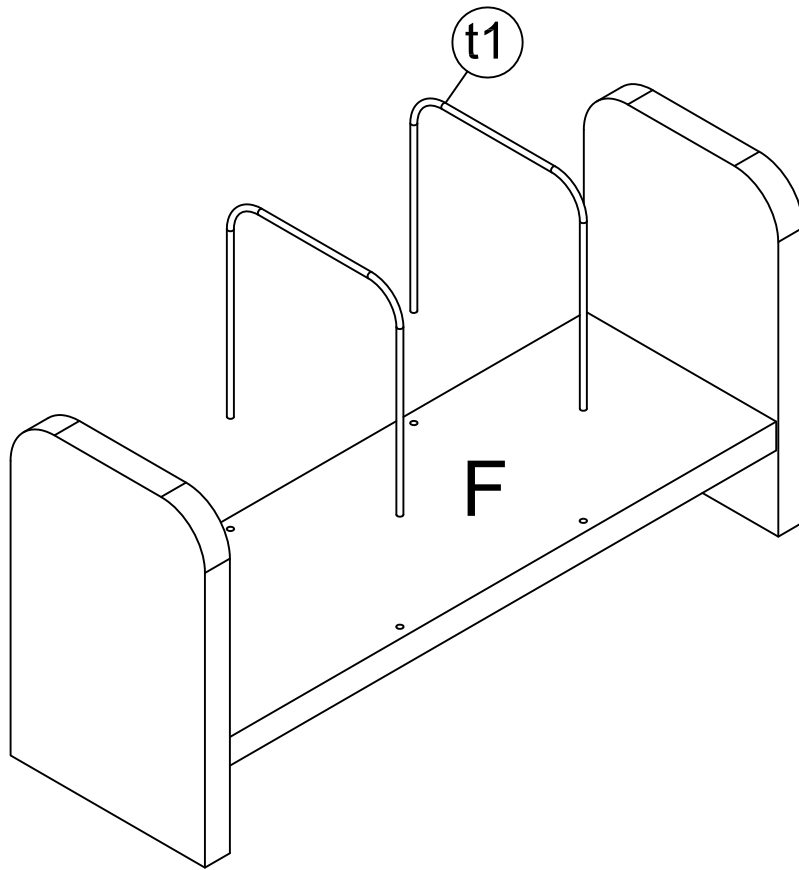

Ⓣ1 The iron bar is inserted into the F plate as illustrated above

You have now successfully completed the assembly on item:

Cupboard

ITEM NO. : OG-EKSH

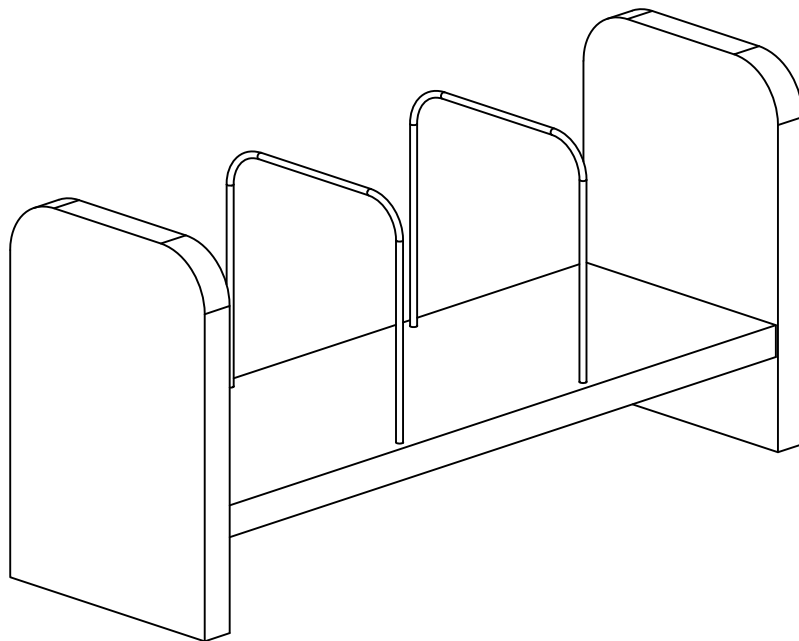

ASSEMBLY INSTRUCTION

Cupboard

ITEM NO. : OG-EKW15156

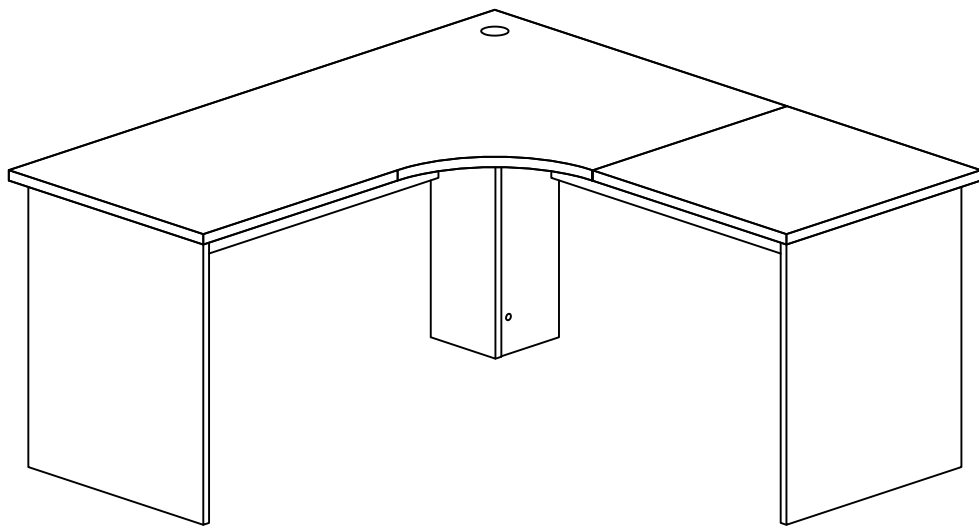

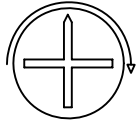

The turning direction of attaching



The arrow direction=front

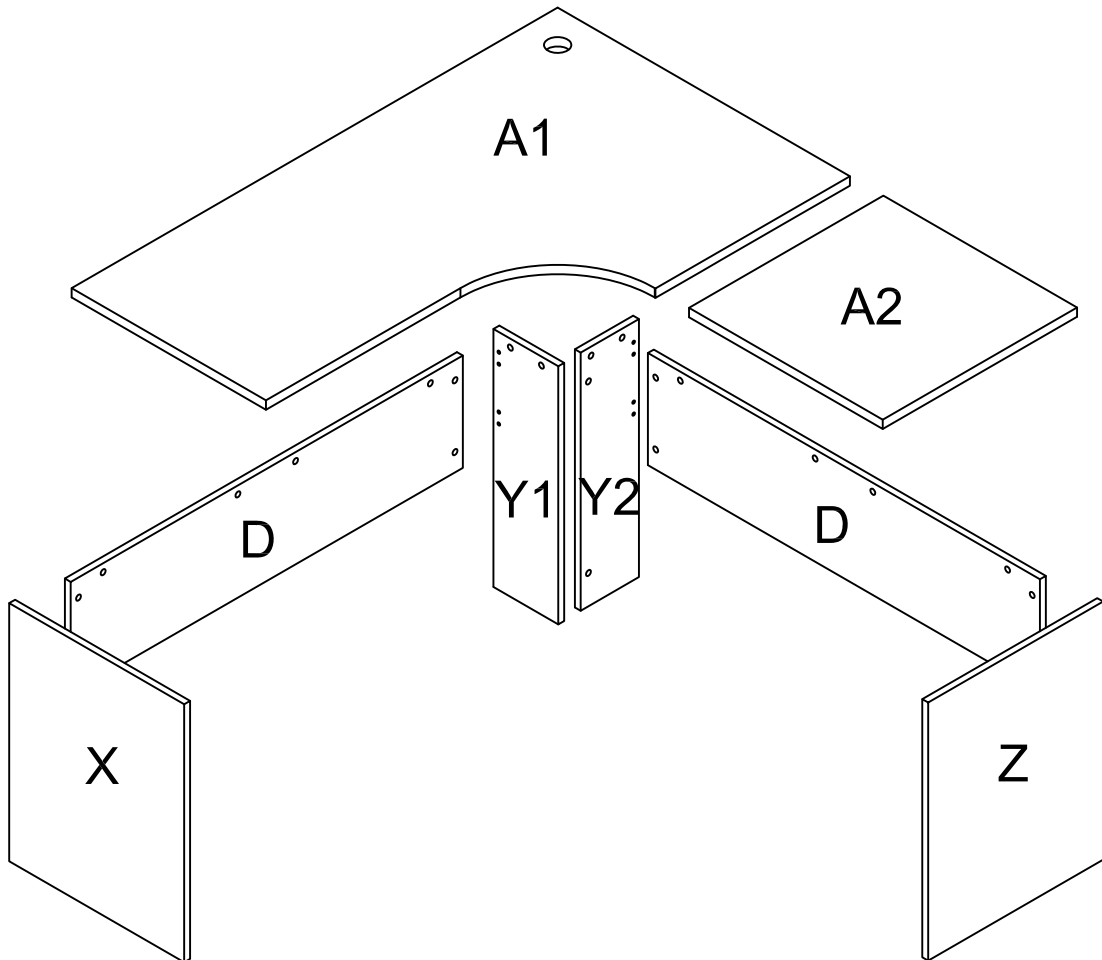

PARTS LIST

ITEM	DESCRIPTION	QTY.	ITEM	DESCRIPTION	QTY.
A1	Top panel	1	Ⓒ2	($\frac{5}{8}$ ") Cam Cover	28
A2	Top panel	1	Ⓔ1	4*16 Screw	32
X	Left side panel	1	Ⓓ1	Bracket	8
Z	Right side panel	1	Ⓒ3	200*60 Connector	2
D	Back panel	1	Ⓔ5	6*12 Screw	16
Y1	Partition	1			
Y2	Partition	1			



Ⓒ2 ($\frac{5}{8}$ ") Cam Cover-28



Ⓔ1 4*16 Screw-32



Ⓓ1 Bracket-8

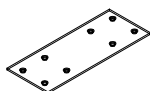

Ⓒ3 200*60 Connector-2



Ⓔ5 6*12 Screw-16

Pre-installed parts

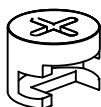

Ⓒ5 Cam

STEP 1

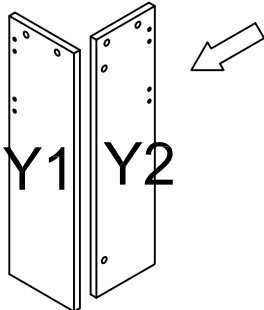

Preparation for Panels Y1 and Y2.

1. Connect Cam bolts and dowels on panel Y2 to the holes on panel Y1 and tighten in a clockwise direction as illustrated above.

STEP 2

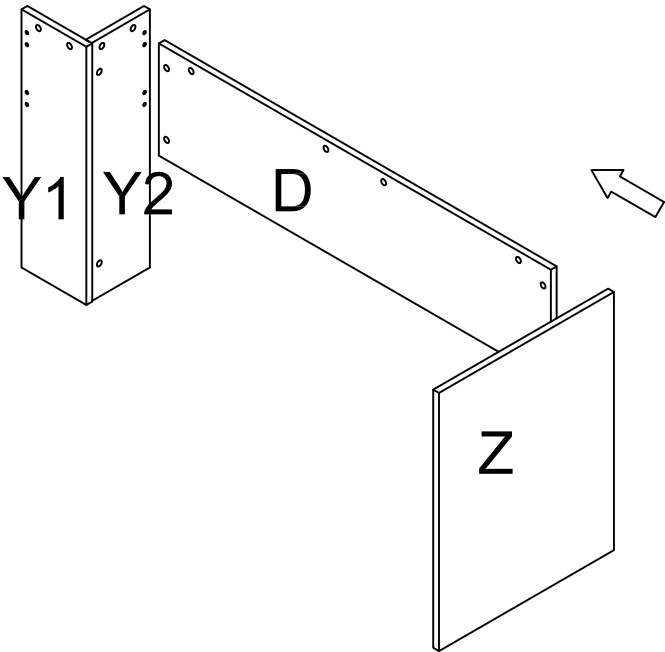

Preparation for Panels D and Z .

1. Connect Cam bolts and dowels on panel D to the holes on panel Y2 and Z and tighten in a clockwise direction as illustrated above.

STEP 3

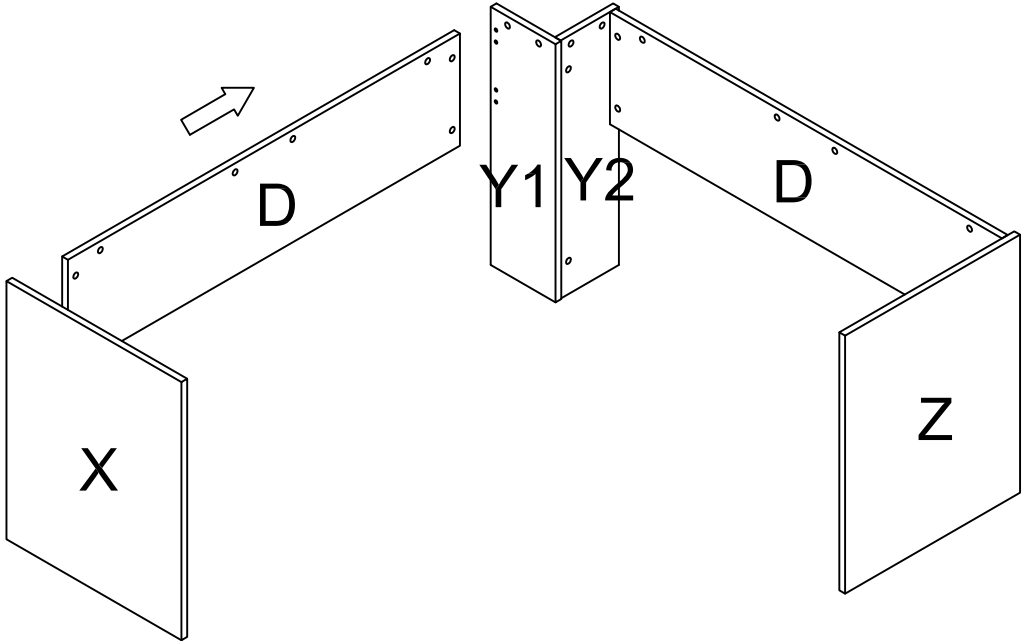

Preparation for Panels D and X .

1.Connect Cam bolts and dowels on panel D to the holes on panel Y1 and X and tighten in a clockwise direction as illustrated above.

STEP 4

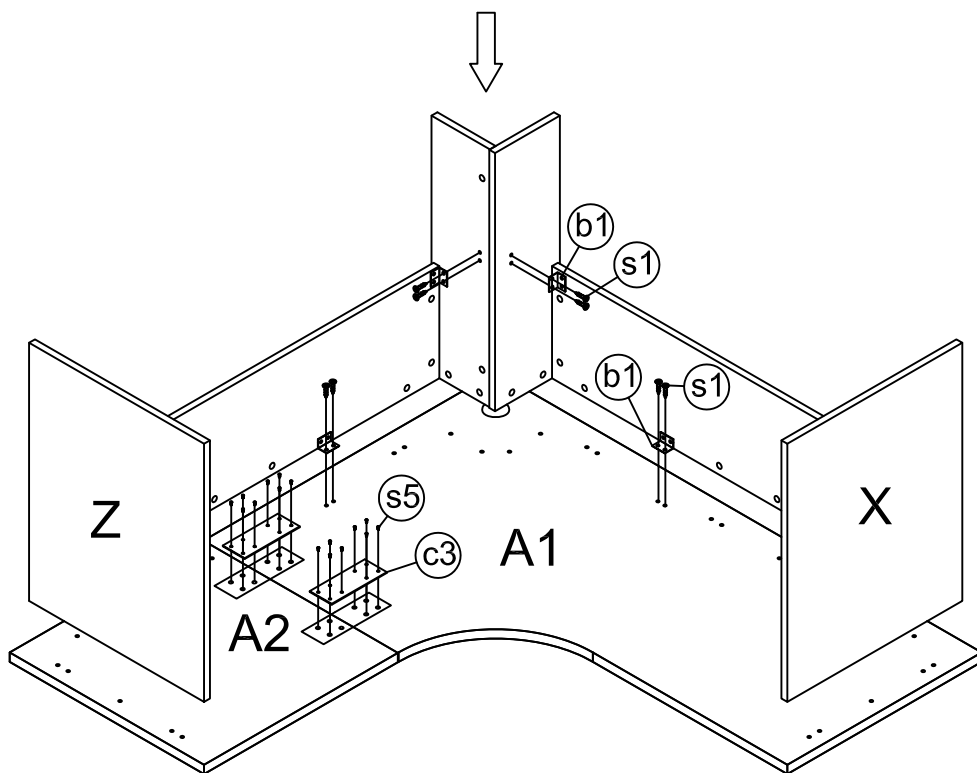

Preparation for Panels A1 and A2 .

1. Attach the connectors (c3) to panels A1 and A2 with screws (s5) and tighten in a clockwise direction as illustrated above.
2. Connect Cam bolts and dowels on panel X,Z,D,Y1 and Y2 to the holes on panel A1 and A2 and tighten in a clockwise direction as illustrated above.
3. Fix Bracket (b1) to panels X,Z,D,Y1,Y2,A1 and A2 with fix bolts (s1) as illustrated above.

You have now successfully completed the assembly on item:

Cupboard

ITEM NO. : OG-EKW15156

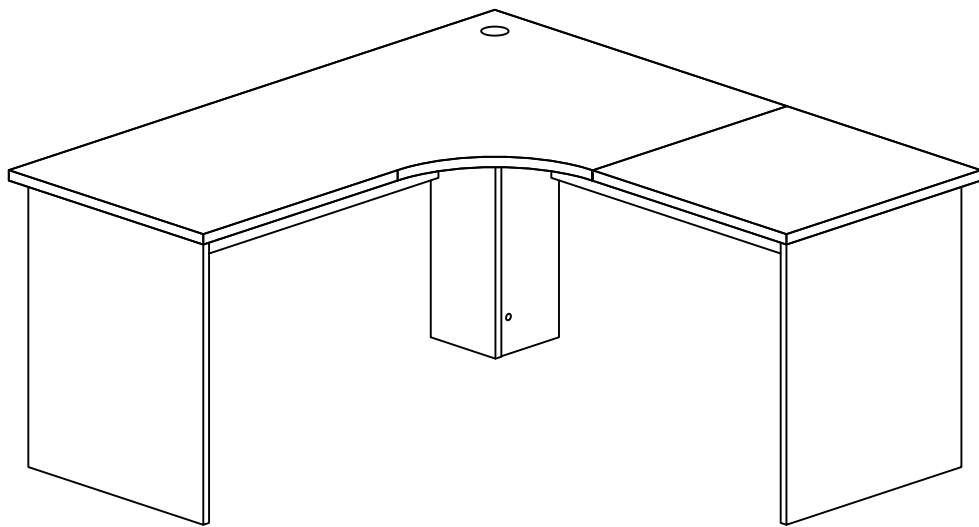

ASSEMBLY INSTRUCTION

Cupboard

ITEM NO. : OG-EKW18186

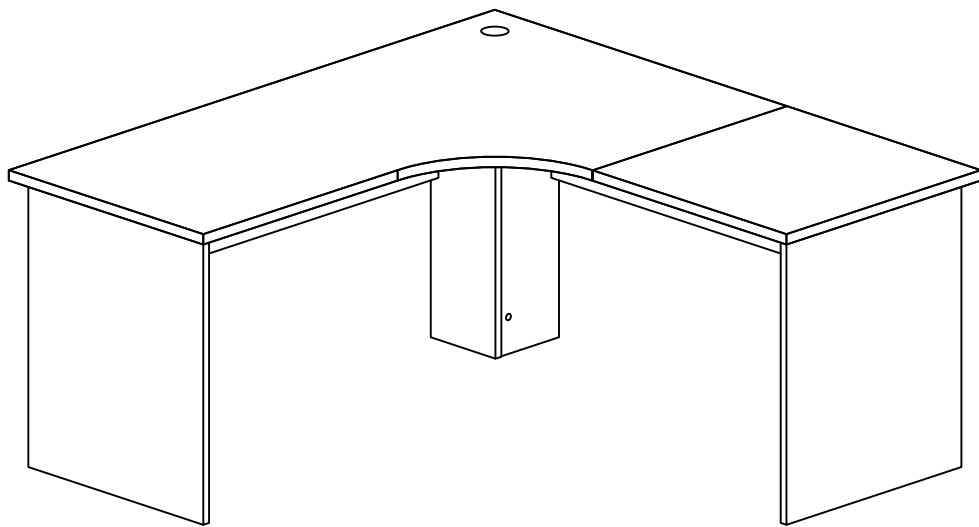

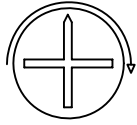

The turning direction of attaching



The arrow direction=front

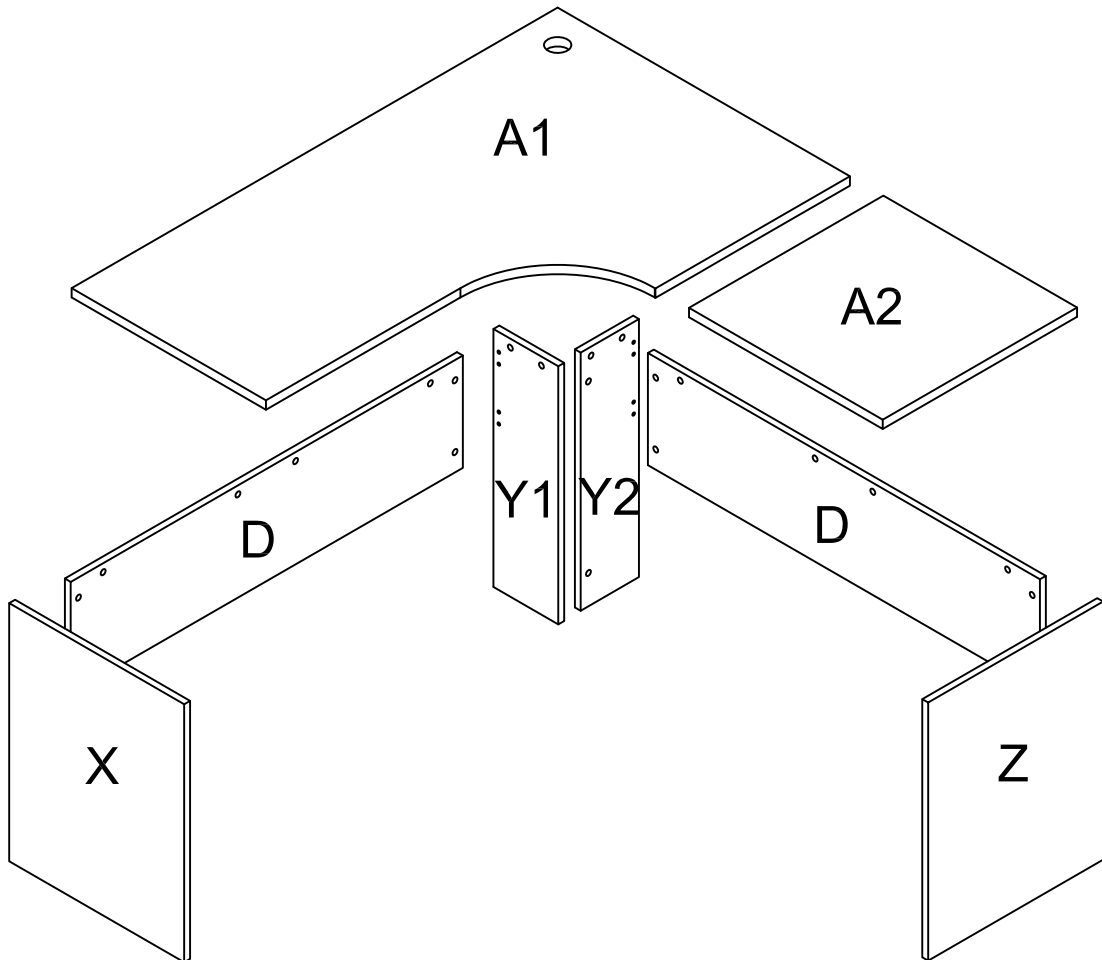

PARTS LIST

ITEM	DESCRIPTION	QTY.	ITEM	DESCRIPTION	QTY.
A1	Top panel	1	Ⓒ2	($\frac{5}{8}$ ") Cam Cover	28
A2	Top panel	1	Ⓐ1	4*16 Screw	32
X	Left side panel	1	Ⓓ1	Bracket	8
Z	Right side panel	1	Ⓒ3	200*60 Connector	2
D	Back panel	1	Ⓐ5	6*12 Screw	16
Y1	Partition	1			
Y2	Partition	1			



Ⓒ2 ($\frac{5}{8}$ ") Cam Cover-28



Ⓐ1 4*16 Screw-32



Ⓓ1 Bracket-8

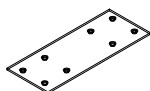

Ⓒ3 200*60 Connector-2



Ⓐ5 6*12 Screw-16

Pre-installed parts

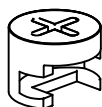

Ⓒ5 Cam

STEP 1

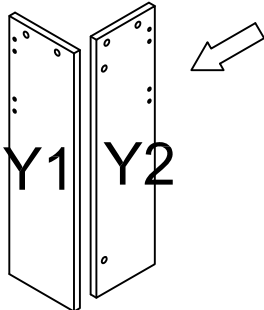

Preparation for Panels Y1 and Y2.

1. Connect Cam bolts and dowels on panel Y2 to the holes on panel Y1 and tighten in a clockwise direction as illustrated above.

STEP 2

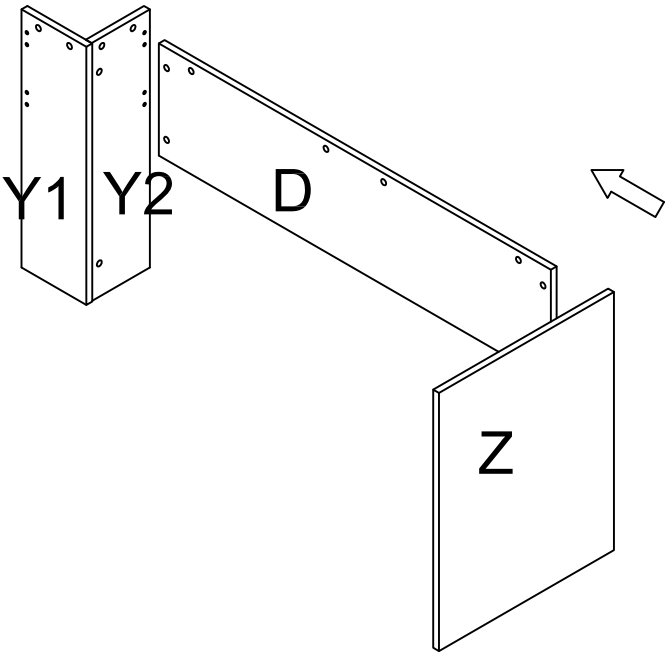

Preparation for Panels D and Z .

1. Connect Cam bolts and dowels on panel D to the holes on panel Y2 and Z and tighten in a clockwise direction as illustrated above.

STEP 3

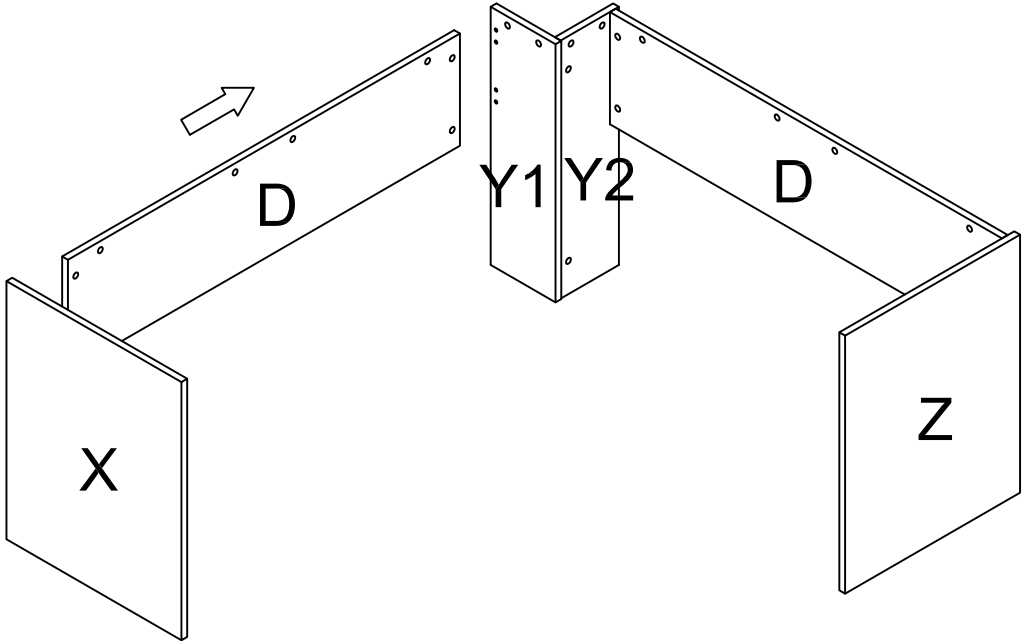

Preparation for Panels D and X .

1.Connect Cam bolts and dowels on panel D to the holes on panel Y1 and X and tighten in a clockwise direction as illustrated above.

STEP 4

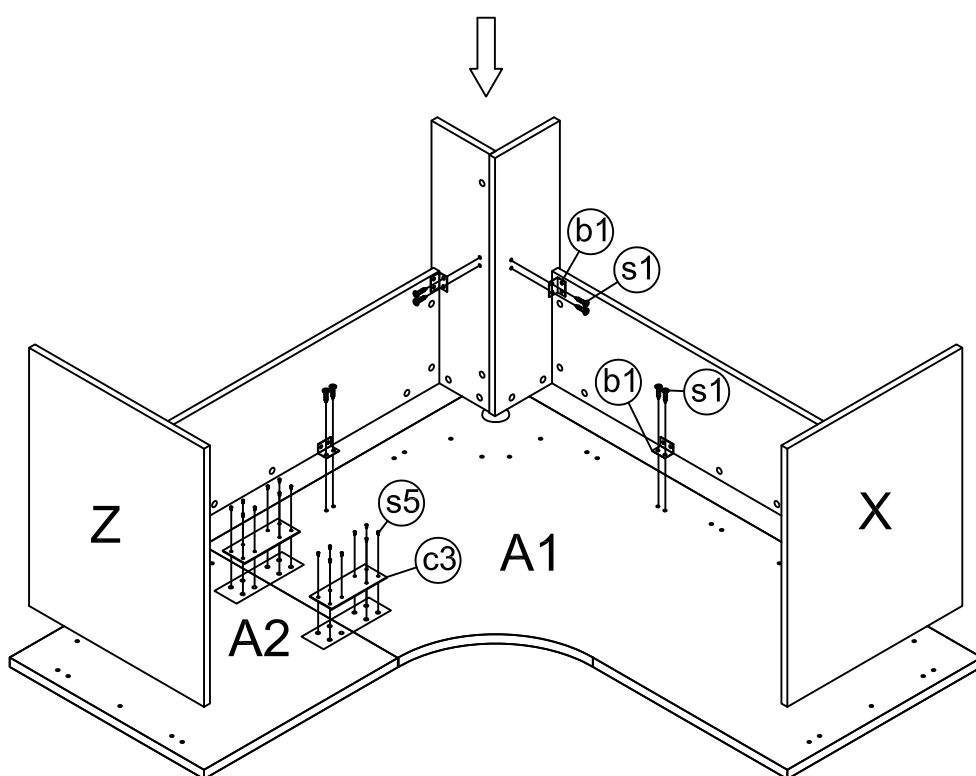

Preparation for Panels A1 and A2 .

1. Attach the connectors (c3) to panels A1 and A2 with screws (s5) and tighten in a clockwise direction as illustrated above.
2. Connect Cam bolts and dowels on panel X,Z,D,Y1 and Y2 to the holes on panel A1 and A2 and tighten in a clockwise direction as illustrated above.
3. Fix Bracket (b1) to panels X,Z,D,Y1,Y2,A1 and A2 with fix bolts (s1) as illustrated above.

You have now successfully completed the assembly on item:

Cupboard

ITEM NO. : OG-EKW18186

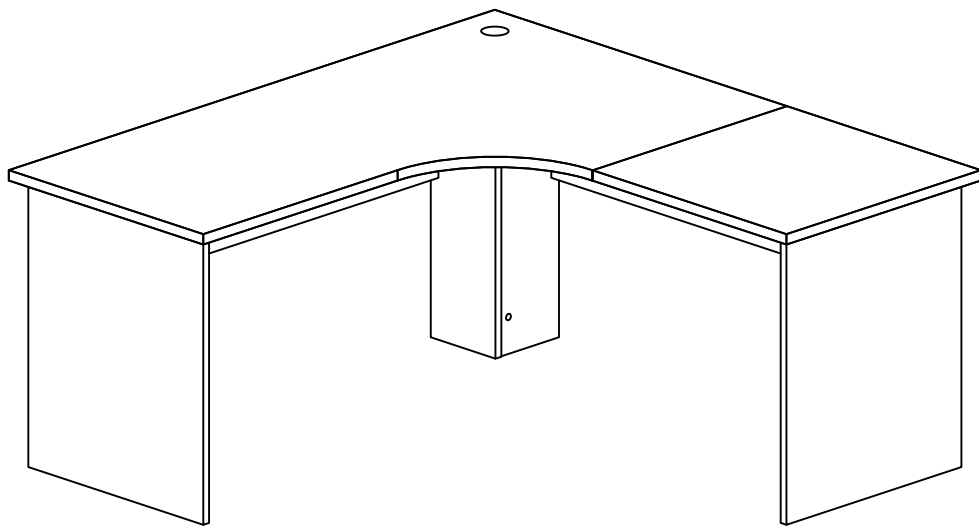

ASSEMBLY INSTRUCTION

Cupboard

ITEM NO. : OG-EKW181875

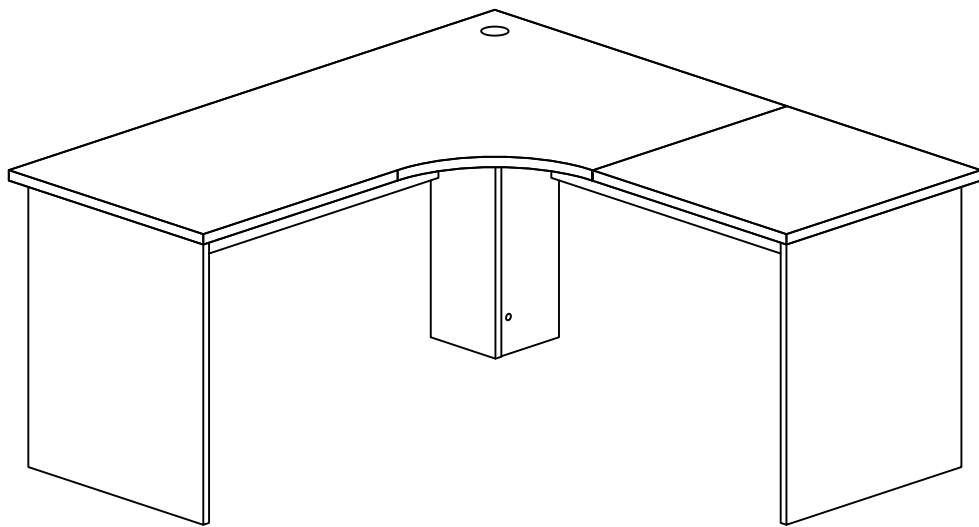

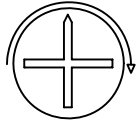

The turning direction of attaching



The arrow direction=front

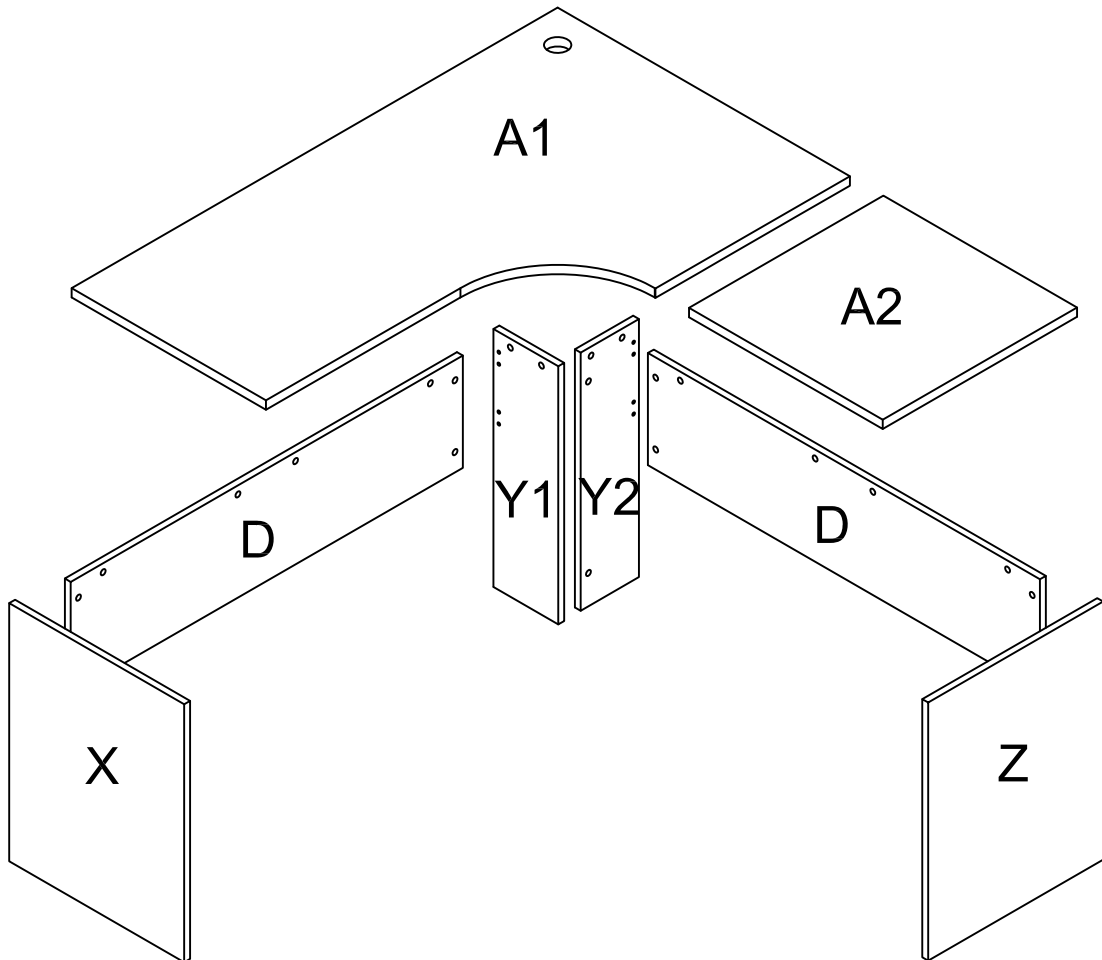

PARTS LIST

ITEM	DESCRIPTION	QTY.	ITEM	DESCRIPTION	QTY.
A1	Top panel	1	Ⓒ2	($\frac{5}{8}$ ") Cam Cover	28
A2	Top panel	1	Ⓔ1	4*16 Screw	32
X	Left side panel	1	Ⓓ1	Bracket	8
Z	Right side panel	1	Ⓒ3	200*60 Connector	2
D	Back panel	1	Ⓔ5	6*12 Screw	16
Y1	Partition	1			
Y2	Partition	1			



Ⓒ2 ($\frac{5}{8}$ ") Cam Cover-28



Ⓔ1 4*16 Screw-32



Ⓓ1 Bracket-8

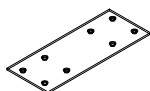

Ⓒ3 200*60 Connector-2



Ⓔ5 6*12 Screw-16

Pre-installed parts

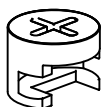

Ⓒ5 Cam

STEP 1

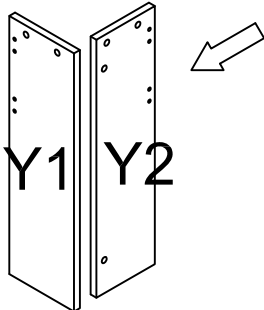

Preparation for Panels Y1 and Y2.

1. Connect Cam bolts and dowels on panel Y2 to the holes on panel Y1 and tighten in a clockwise direction as illustrated above.

STEP 2

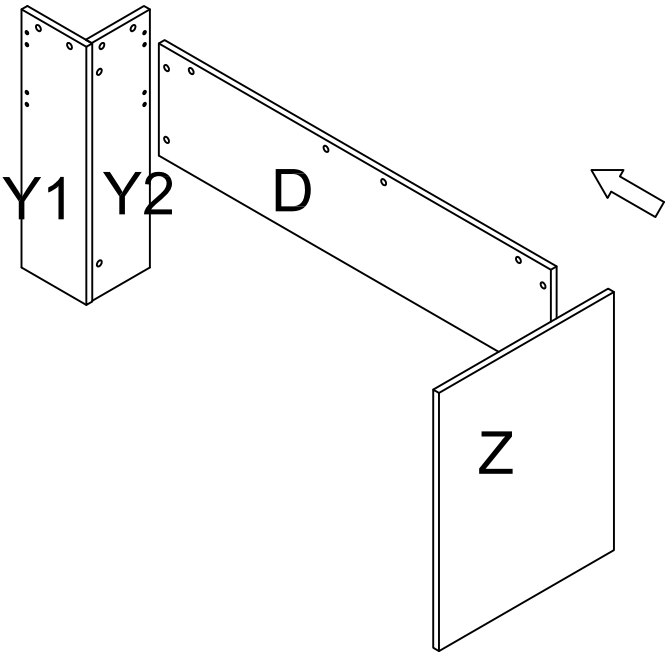

Preparation for Panels D and Z .

1. Connect Cam bolts and dowels on panel D to the holes on panel Y2 and Z and tighten in a clockwise direction as illustrated above.

STEP 3

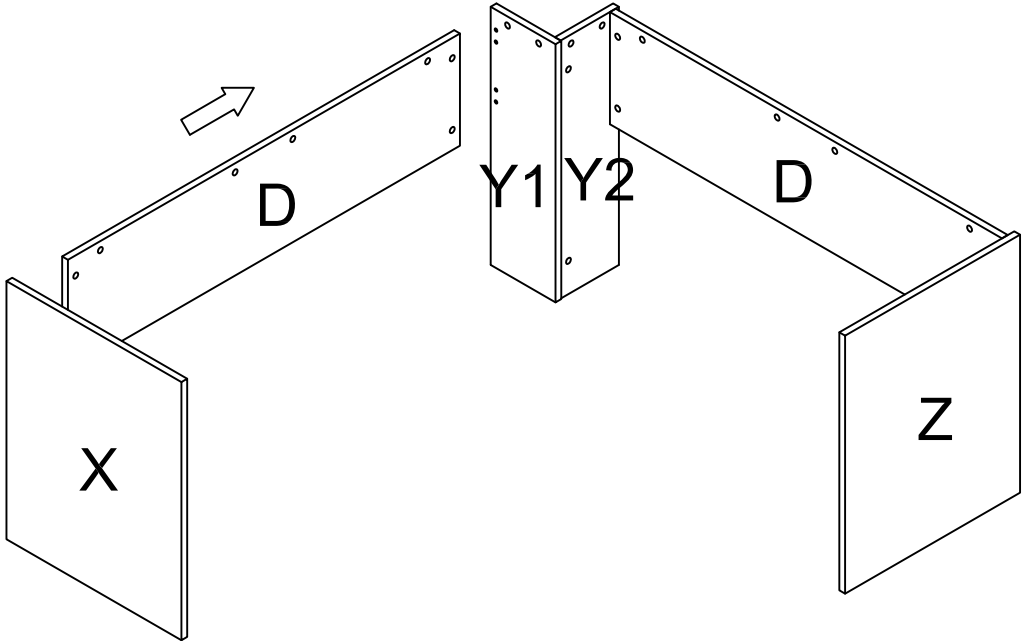

Preparation for Panels D and X .

1.Connect Cam bolts and dowels on panel D to the holes on panel Y1 and X and tighten in a clockwise direction as illustrated above.

STEP 4

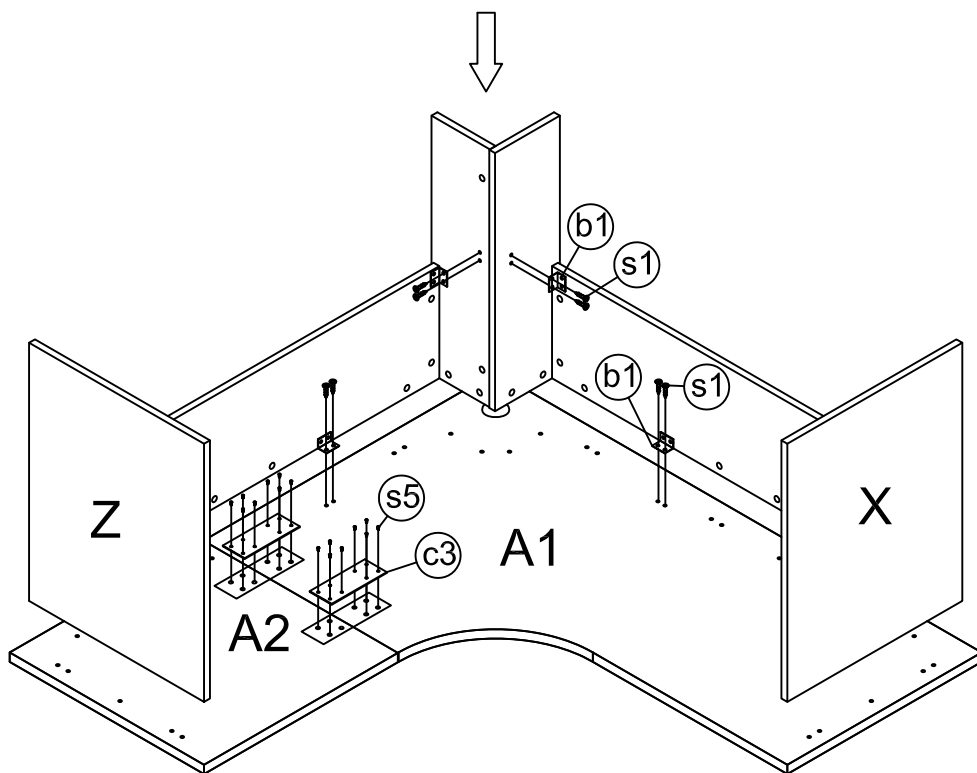

Preparation for Panels A1 and A2 .

1. Attach the connectors (c3) to panels A1 and A2 with screws (s5) and tighten in a clockwise direction as illustrated above.
2. Connect Cam bolts and dowels on panel X,Z,D,Y1 and Y2 to the holes on panel A1 and A2 and tighten in a clockwise direction as illustrated above.
3. Fix Bracket (b1) to panels X,Z,D,Y1,Y2,A1 and A2 with fix bolts (s1) as illustrated above.

You have now successfully completed the assembly on item:

Cupboard

ITEM NO. : OG-EKW181875

