



---

# Phone Booth

Assembly Instructions

# Phone Booth

## Parts List

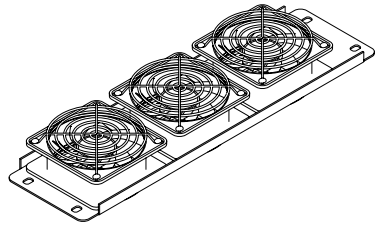

Fan (x1)



Hinge (x3)

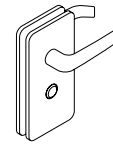

Handle (x1)

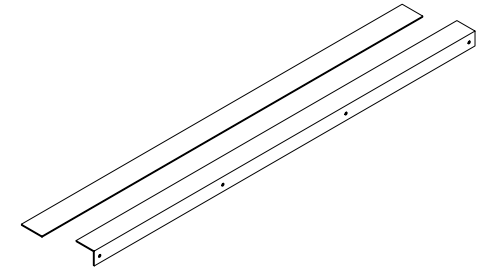

Threshold plate (x1)

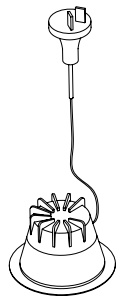

Light (x1)

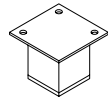

Metal feet (x6)

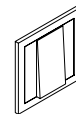

Switch (x1)



M6 bolts

M6 x 50 mm (x36)  
M6 x 40 mm (x4)  
M6 x 20 mm (x32)  
M6 x 12 mm (x18)



Self tapping screws

3.5 x 40 mm (x4)  
3.5 x 20 mm (x4)  
4 x 30 mm (x32)

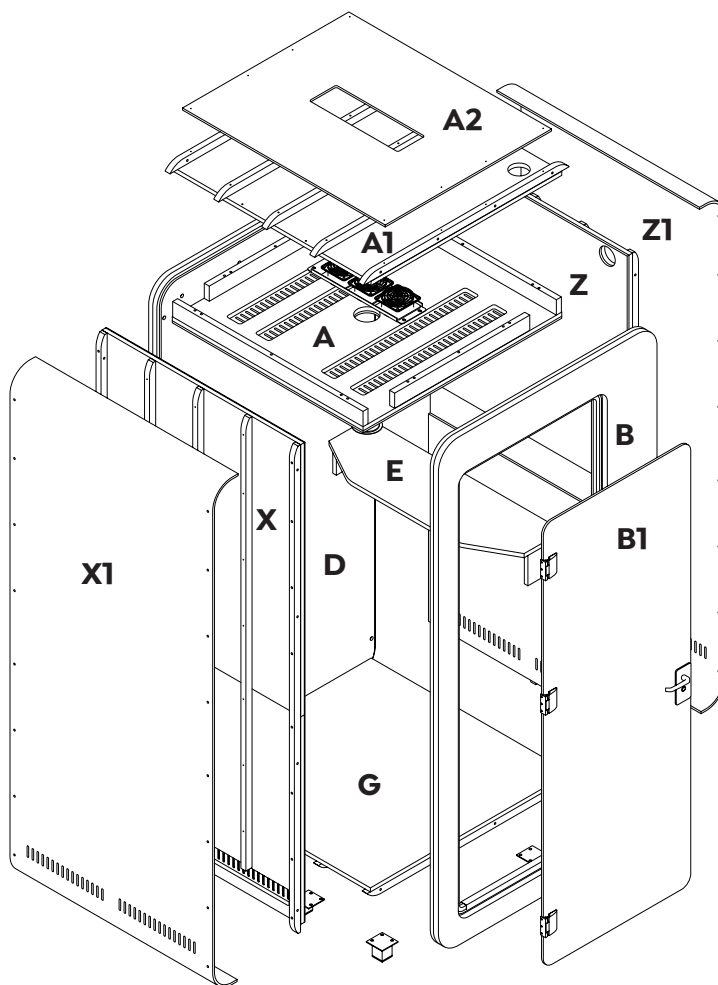

- A** - Ceiling Panel
- A1** - Top Panel
- A2** - E-panel Top
- B** - Front Panel
- B1** - Glass Door
- D** - Back Panel
- E** - Shelf
- G** - Bottom Panel
- X** - Side panel
- X1** - Side E-panel
- Z** - Side Panel
- Z1** - Side E-panel

# Phone Booth

## Assembly Instructions

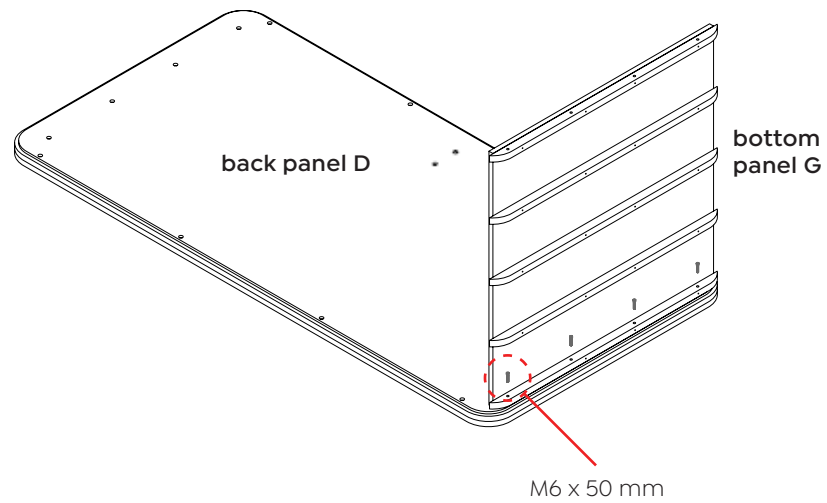

**STEP 1:** Bolt the bottom to the back panel.

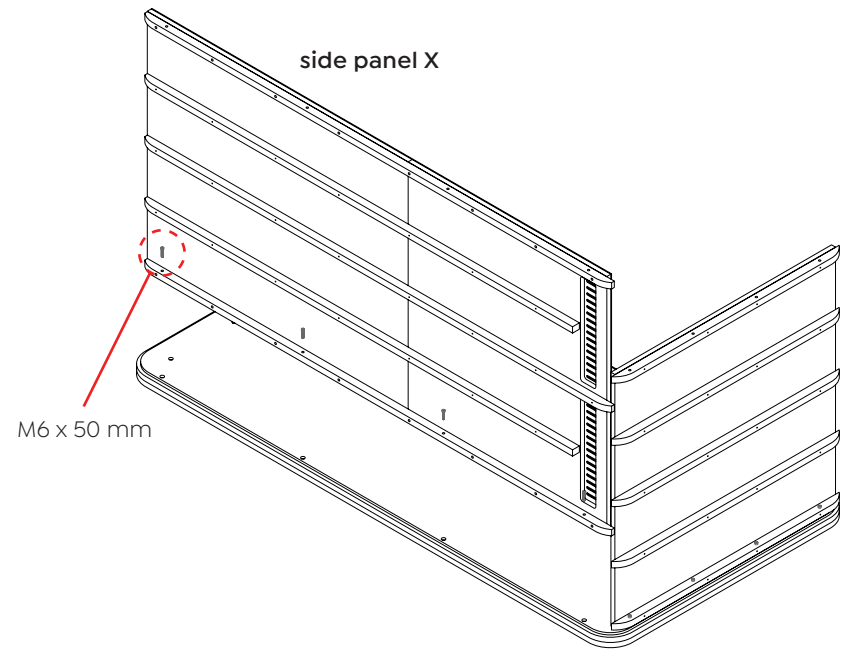

**STEP 2:** Bolt the side panel to the back panel.

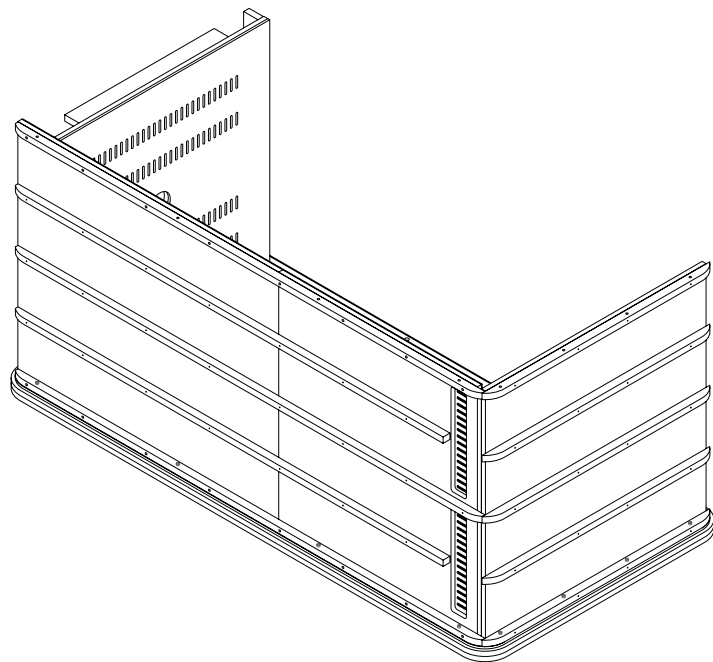

**STEP 3:** Bolt the ceiling panel A to the back panel D and side panel X.

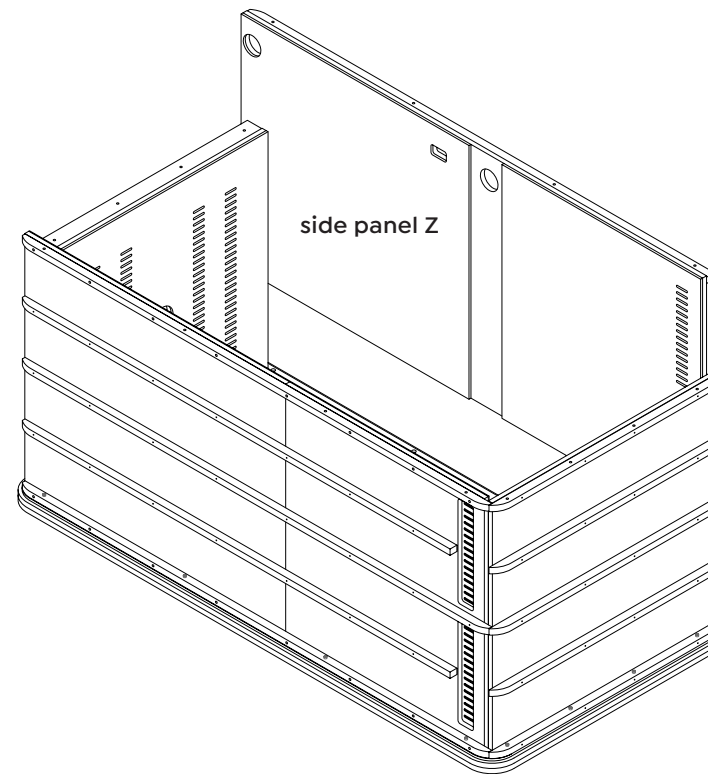

**STEP 4:** Bolt the side panel Z to the back panel.



**TEMPERED GLASS DOOR**

Must be recycled at specialist recycling centre

# Phone Booth

## Assembly Instructions

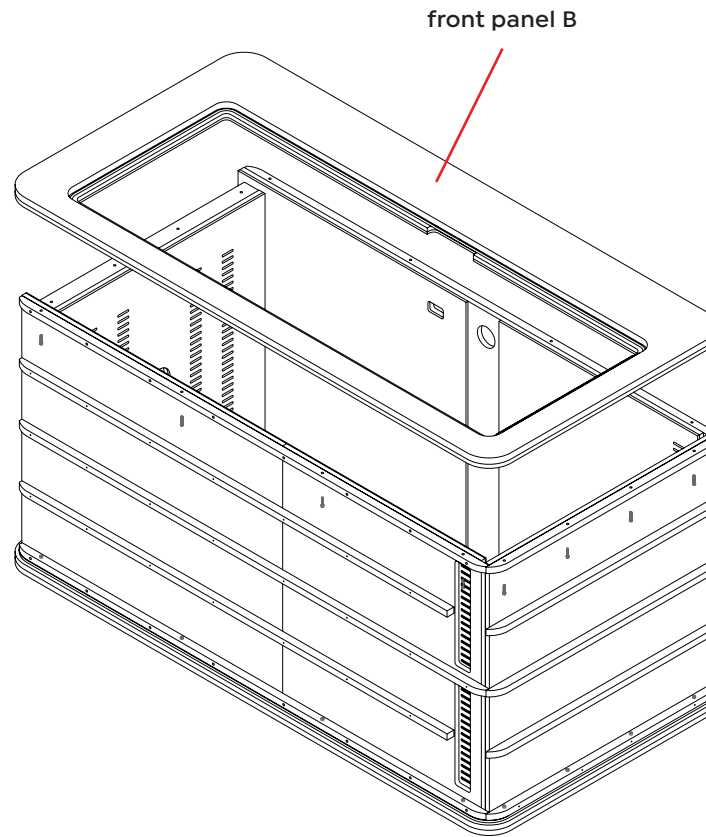

**STEP 5:** Bolt the front panel B.

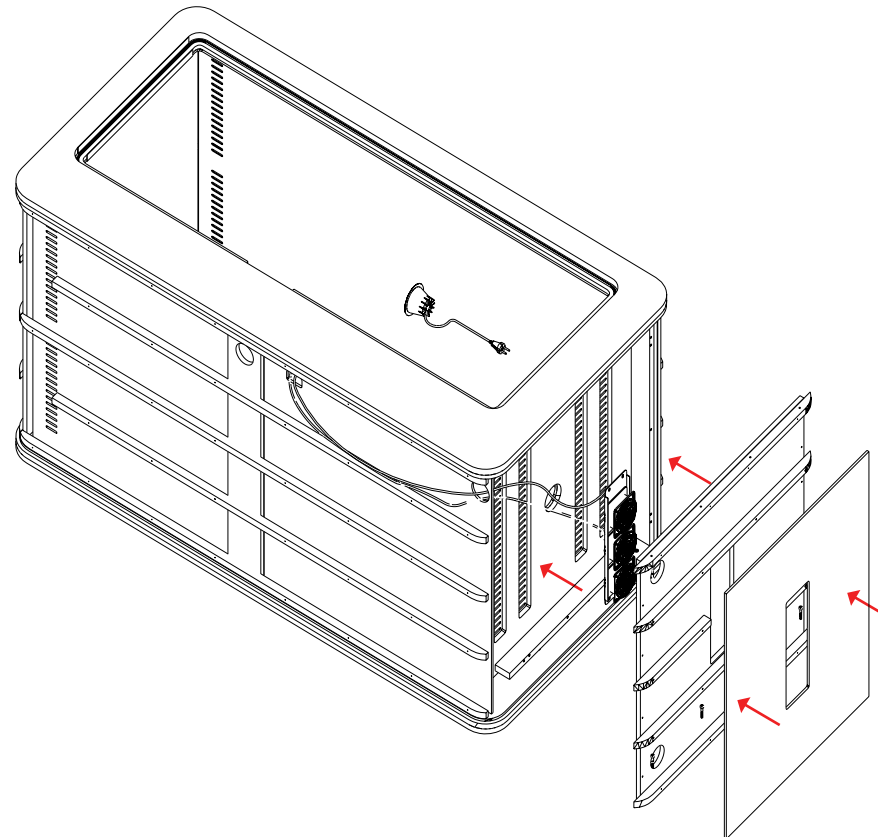

**STEP 6:** Install the switch, light and fan on the ceiling panel A and bolt the top panel A1 along with the A2 E-panel.



**TEMPERED GLASS DOOR**  
Must be recycled at specialist  
recycling centre

# Phone Booth

## Assembly Instructions

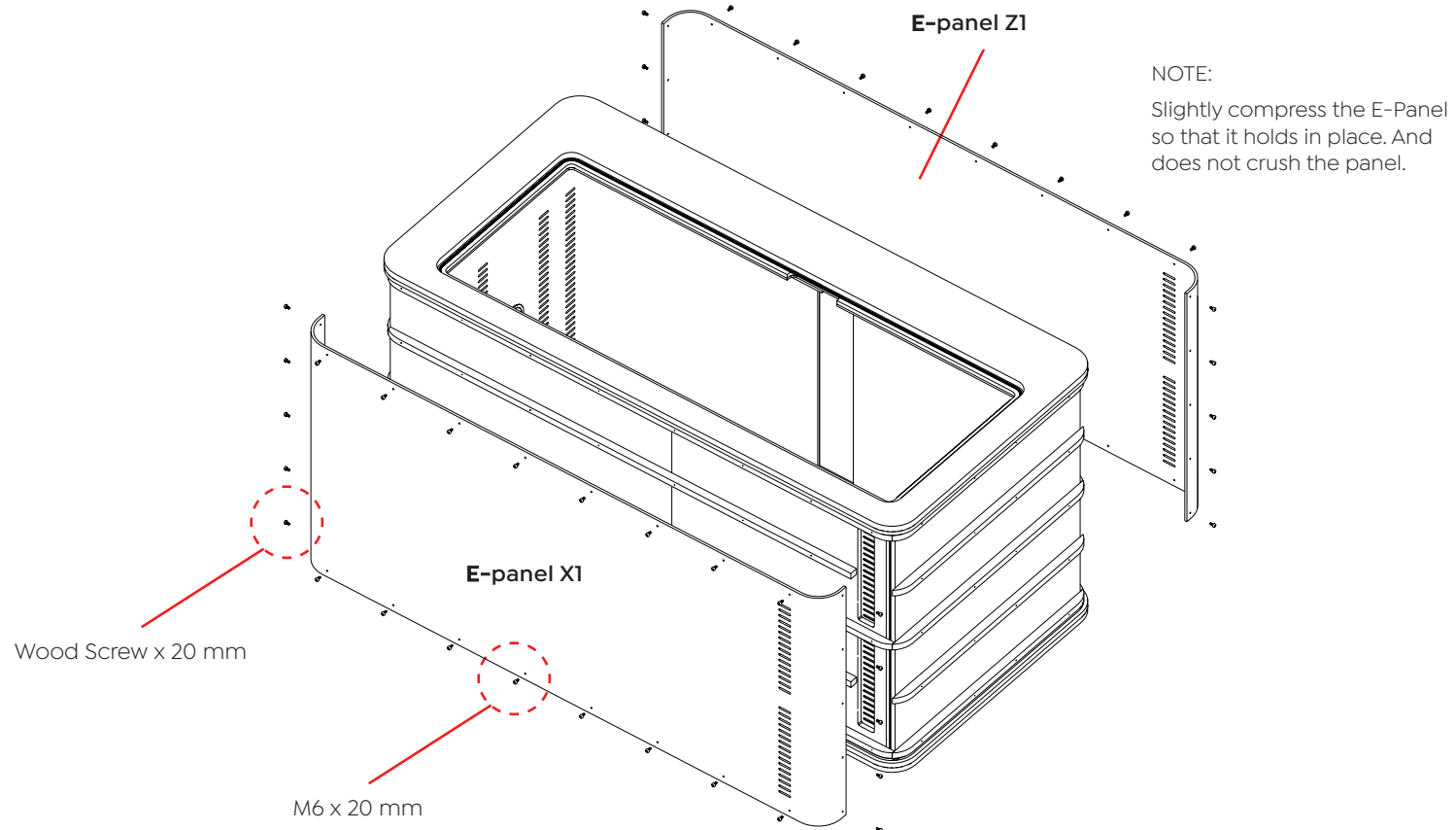

**STEP 7:** Bolt the E-panels X1 and Z1.



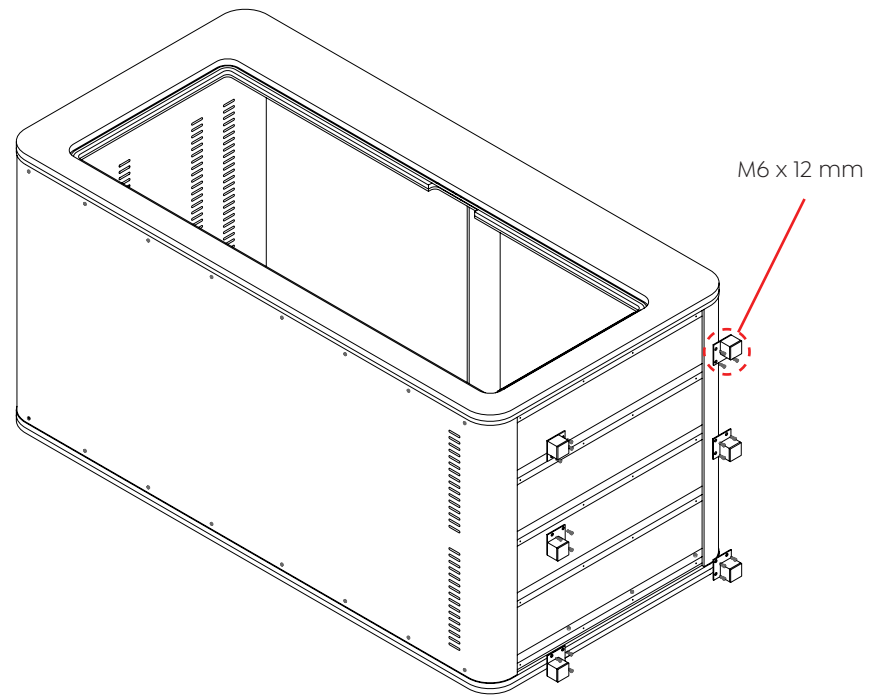

**STEP 8:** Bolt the metal feet to the bottom panel.



**TEMPERED GLASS DOOR**  
Must be recycled at specialist  
recycling centre

# Phone Booth

## Assembly Instructions

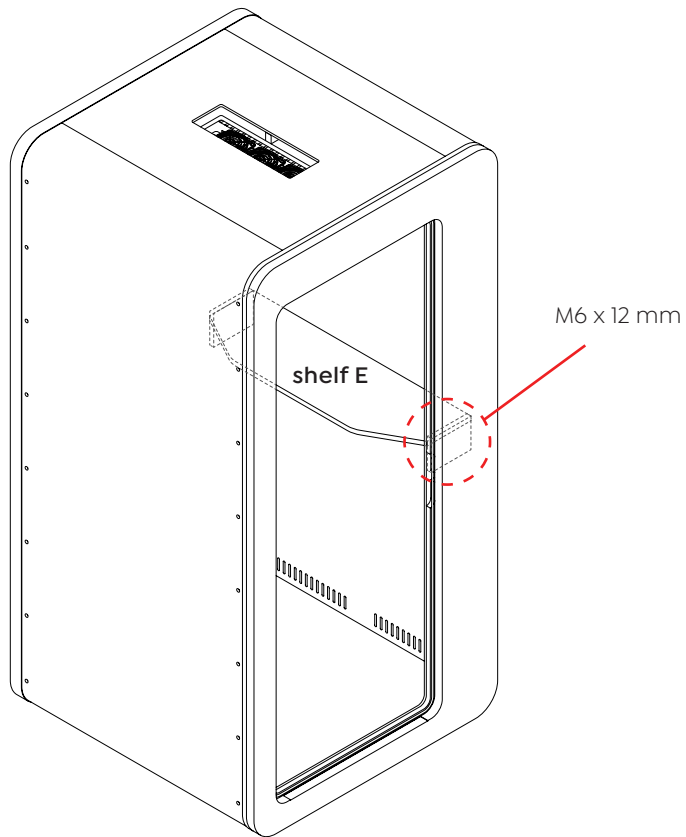

**STEP 9:** Bolt the shelf E to the front and back panel.

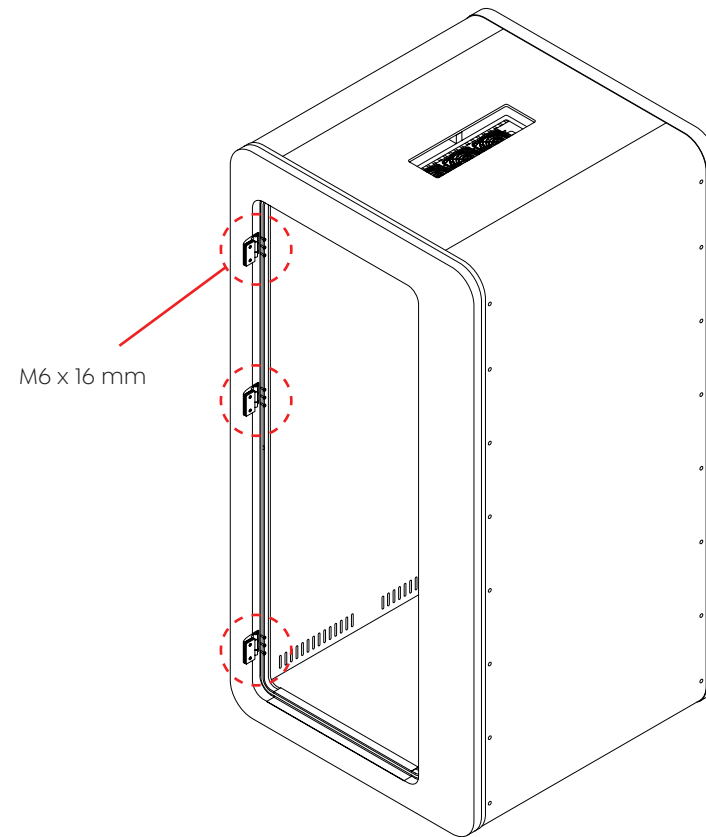

**STEP 10:** Bolt the hinges to the inner edge of the front panel.

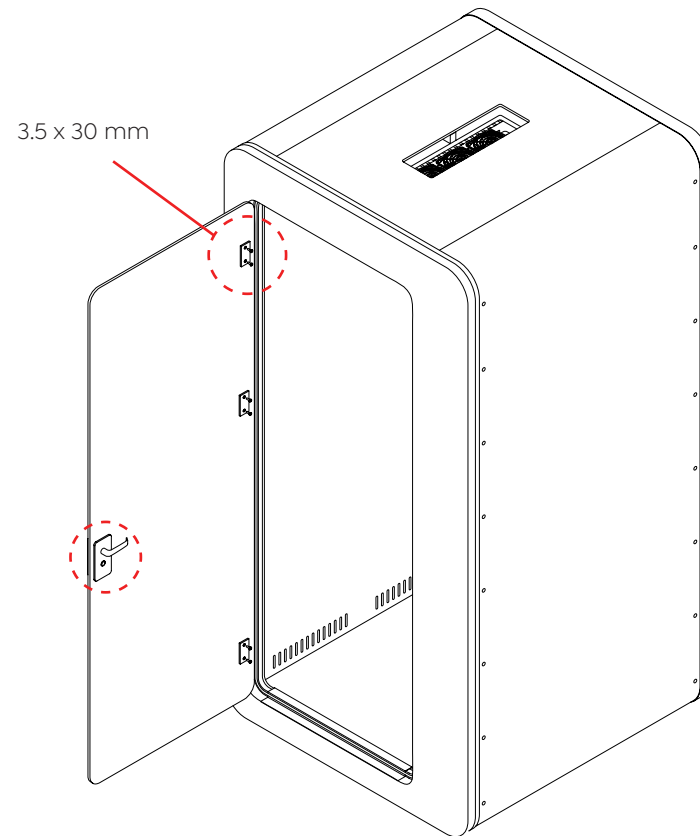

**STEP 11:** Bolt the glass door B1 to the hinges and add the handle.



**TEMPERED GLASS DOOR**  
Must be recycled at specialist  
recycling centre

# Phone Booth

## Softwiring



General recommended settings for the sensor:

- 300 or 500 Lux
- 5 minutes on Timer 1
- Sensitivity set to about  $\frac{3}{4}$  the way to full



**Sydney** 02 8188 2732  
**Melbourne** 03 9111 0315  
**Brisbane** 07 3733 1923  
**Adelaide** 08 7111 0810  
**Perth** 08 9468 2707

[info@olgoffice.com](mailto:info@olgoffice.com)

[myolg.online](http://myolg.online) | [olgoffice.com](http://olgoffice.com) | [officedesigner.net](http://officedesigner.net) | [motionoffice.com](http://motionoffice.com)