

Rover Range (50-ROMBC-0919)

Assembly Instructions

Rover Range (50-ROMBC-0919)

Components List

ITEM	DESCRIPTION	QTY
A	Top Panel	1
X	Left Side Panel	1
Z	Right Side Panel	1
D	Back Panel	1
E	Moveable Shelf	3
F	Immovable Panel	1
G	Bottom	1

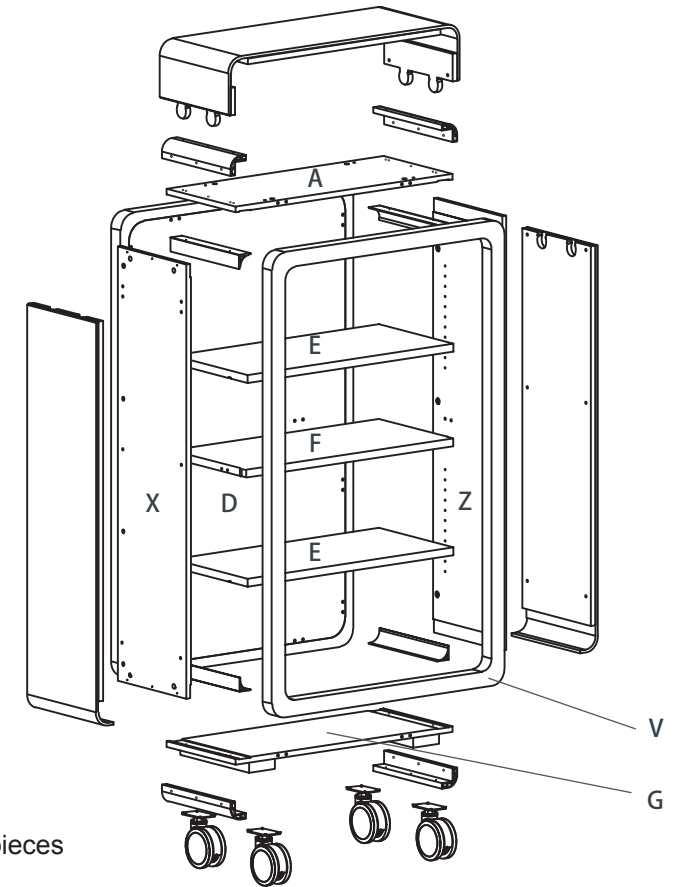
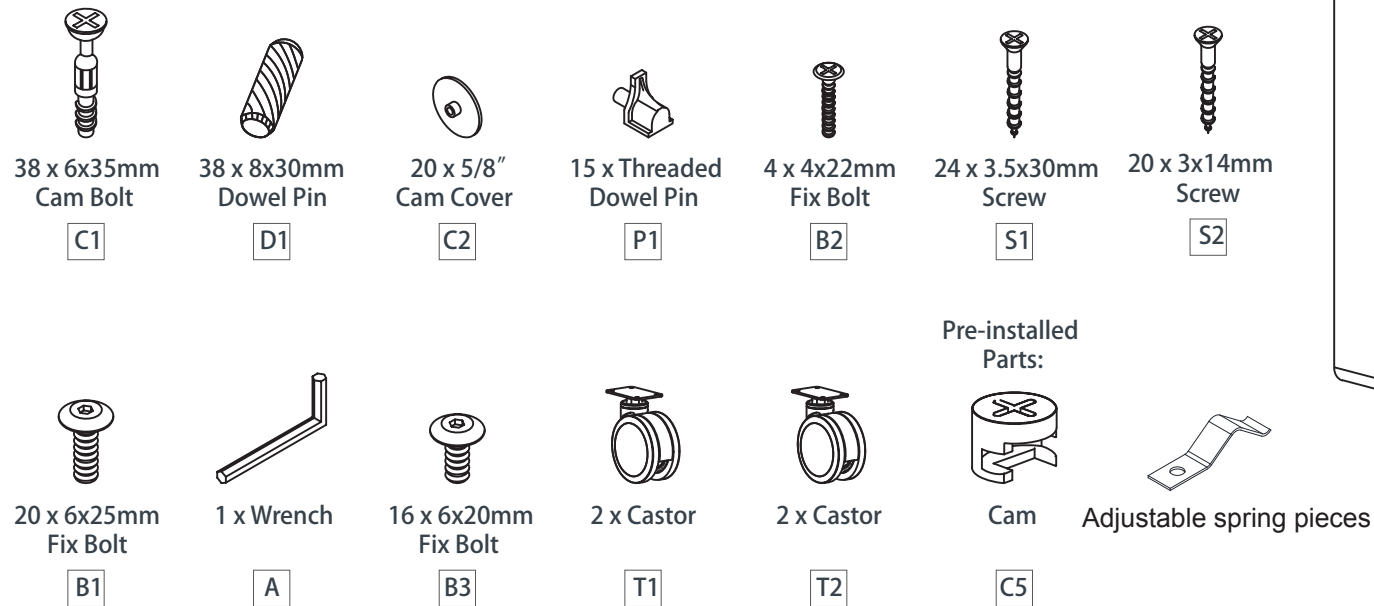

STEP 1:

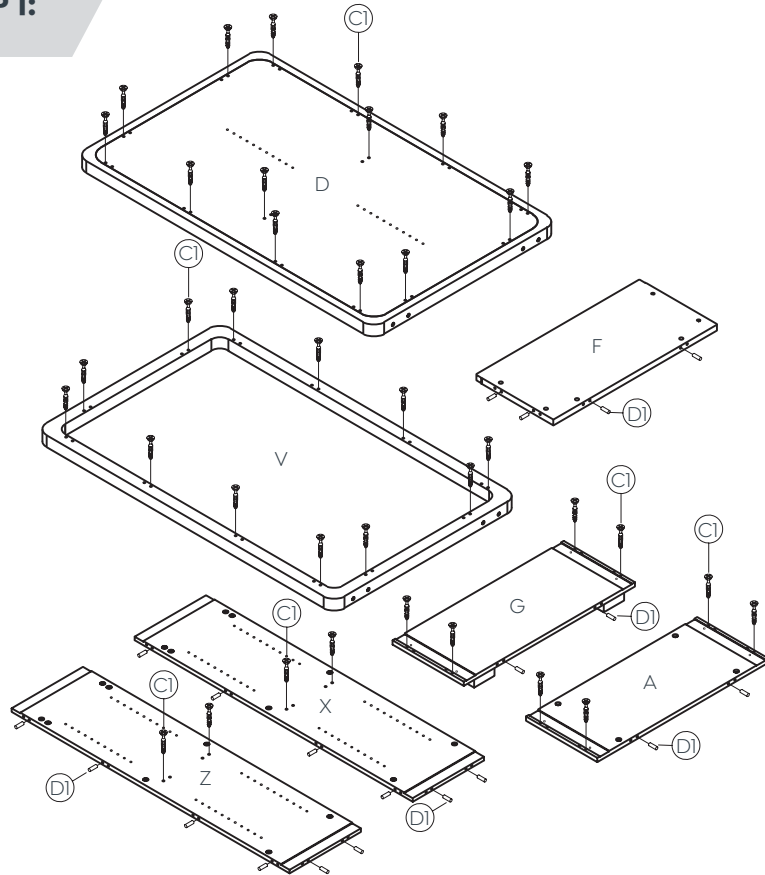

Preparation for Top panel A, Bottom panel G, Left side panel X, Right side panel Z, Back panel D, Immovable panel F

1. Insert cam bolts C1 and dowel pins D1 into panels A,G,F,D,X and Z as illustrated above.

STEP 2:

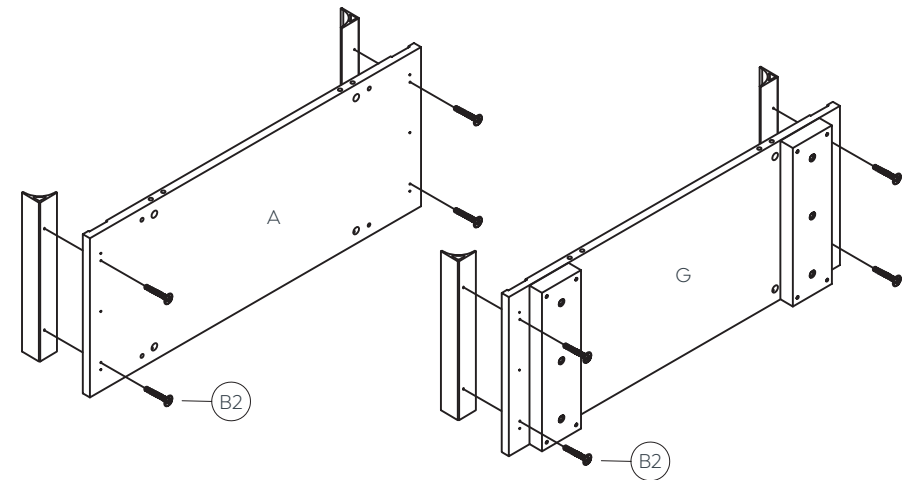

1. Install the aluminum piece and A, G panel together with bolts B2 as illustrated above.

Rover Range (50-ROMBC-0919)

Assembly Instructions

STEP 3:

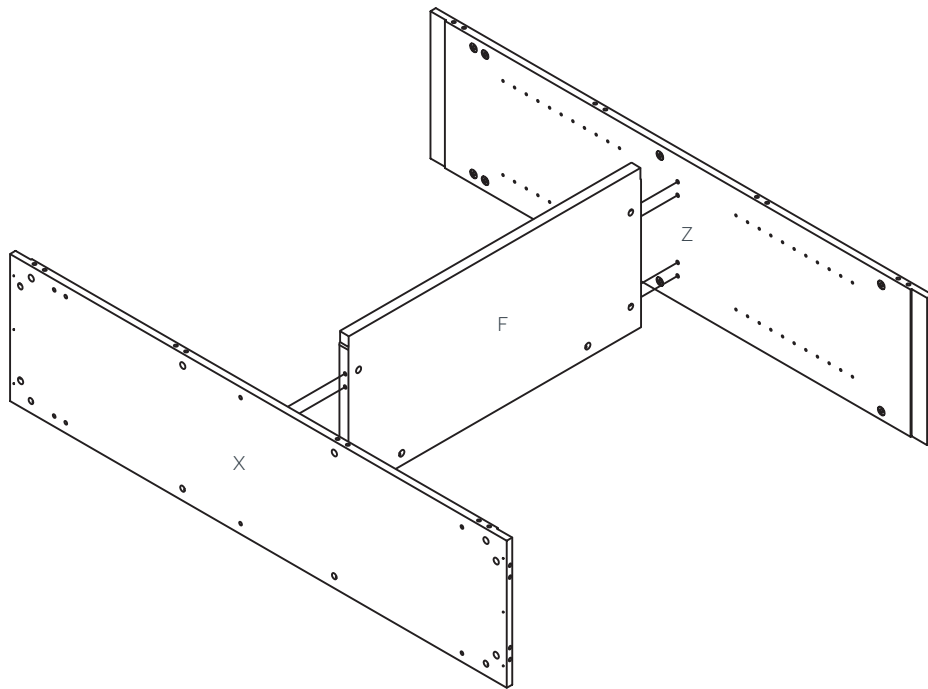

Panel X/Z assembly

1. Insert cam bolts C1 and dowel pins D1 into panels X, Z into cams on panel F and tighten in a clockwise direction as illustrated above.

STEP 4:

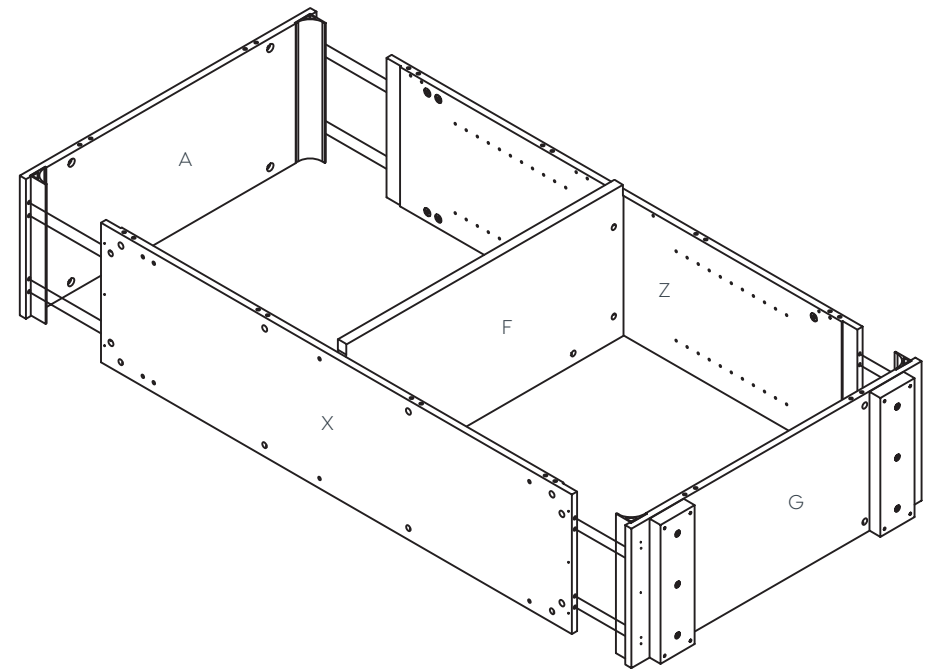

Panel A/G assembly

1. Insert cam bolts C1 and dowel pins D1 into panels A, G into cams on panel X, Z and tighten in a clockwise direction as illustrated above.

STEP 5:

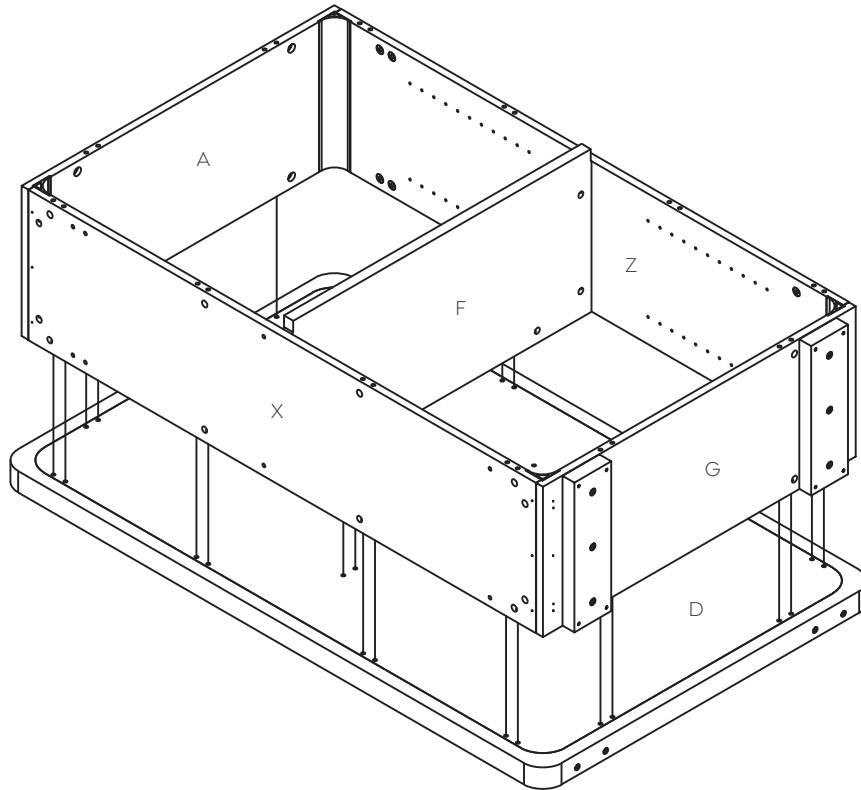

Panel D assembly

1. Insert cam bolts C1 and dowel pins D1 on panel D into cams on panel X, Z, A, G, F and tighten in clockwise direction as illustrated above.

STEP 6:

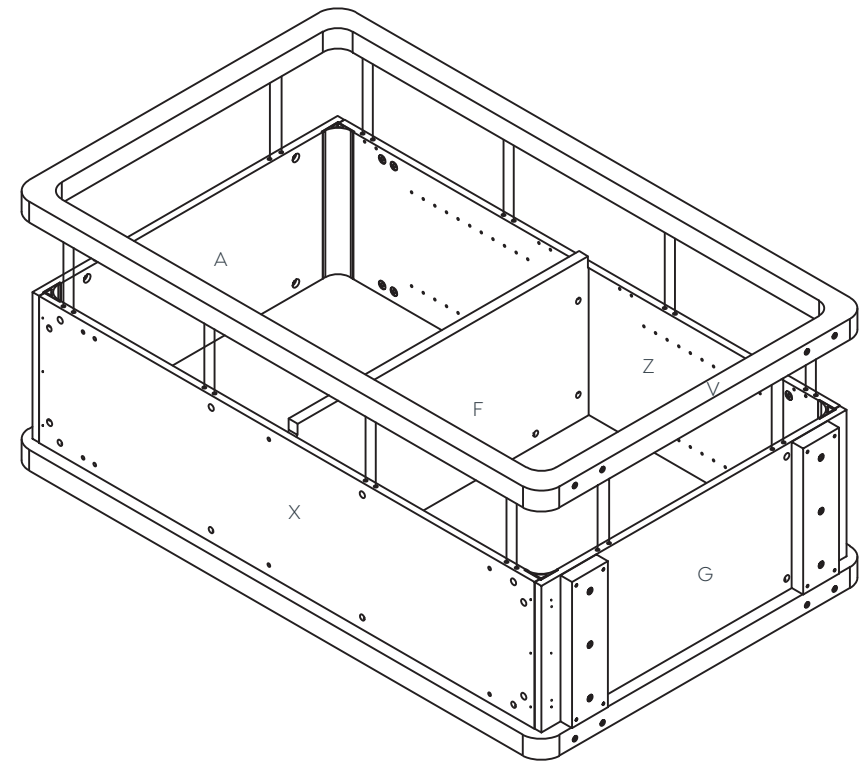

Panel V assembly

1. Insert cam bolts C1 and dowel pins D1 on panel V into cams on panel X, Z, A, G, F and tighten in clockwise direction as illustrated above.

Rover Range (50-ROMBC-0919)

Assembly Instructions

STEP 7:

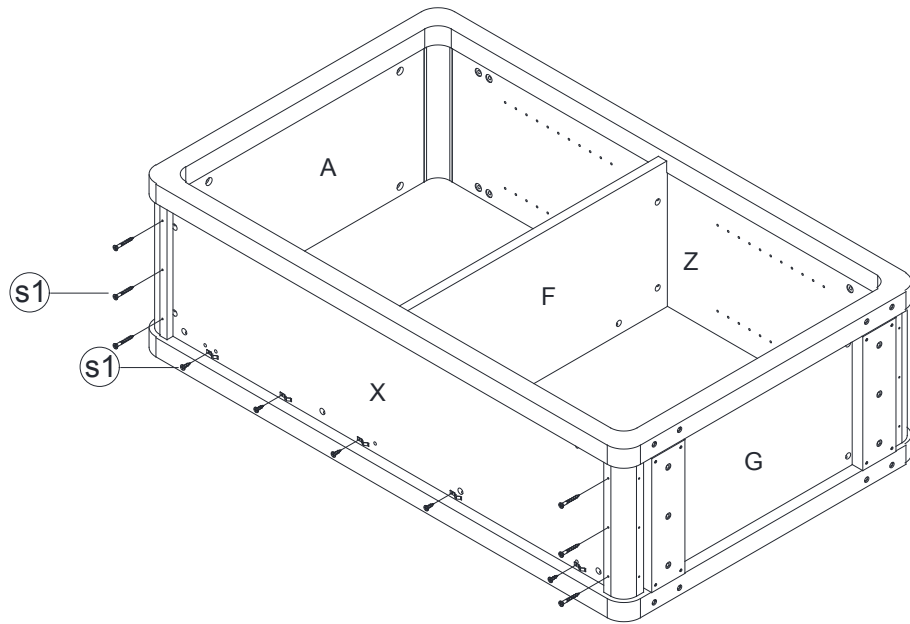

1. Install the aluminum piece and X, Z, A, G panel together with screw S1 as illustrated above.
2. Install the aluminum piece and X, Z panel together with screw S2 as illustrated above.

STEP 8:

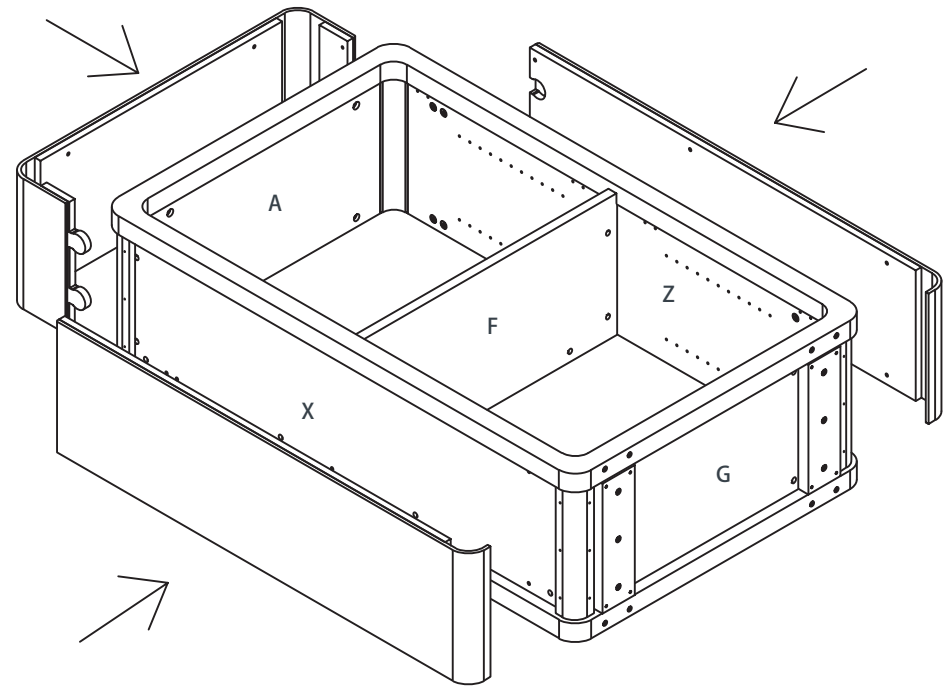

Panel A/G assembly

1. Insert cam bolts C1 and dowel pins D1 into panels A, G into cams on panel X, Z and tighten in a clockwise direction as illustrated above.

STEP 9:

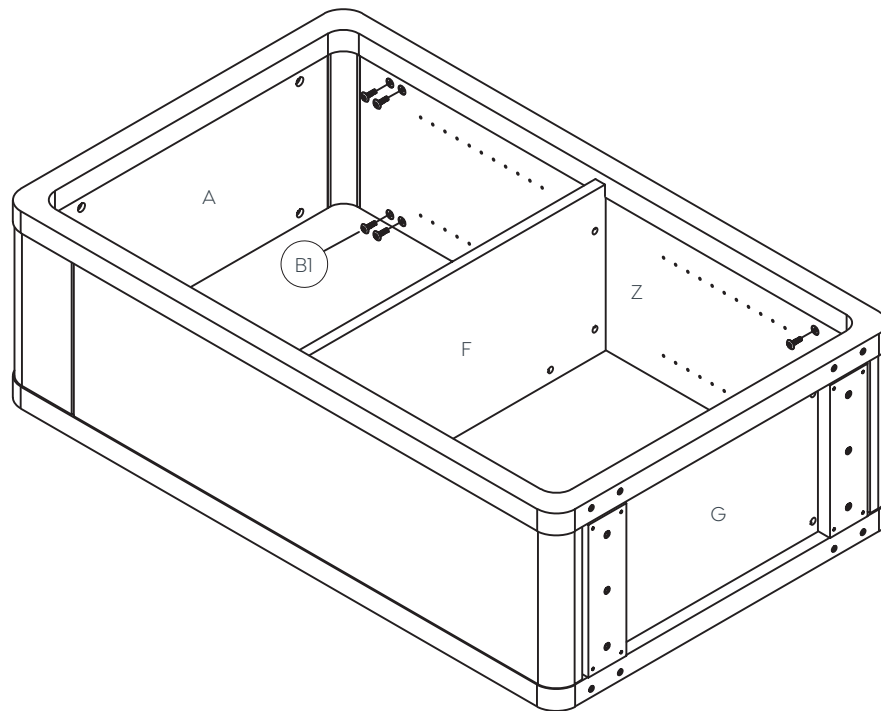

1. Insert fix bolt BI on panel A, X, Z into cam on eva and tighten in clockwise direction as illustrated above.

STEP 10:

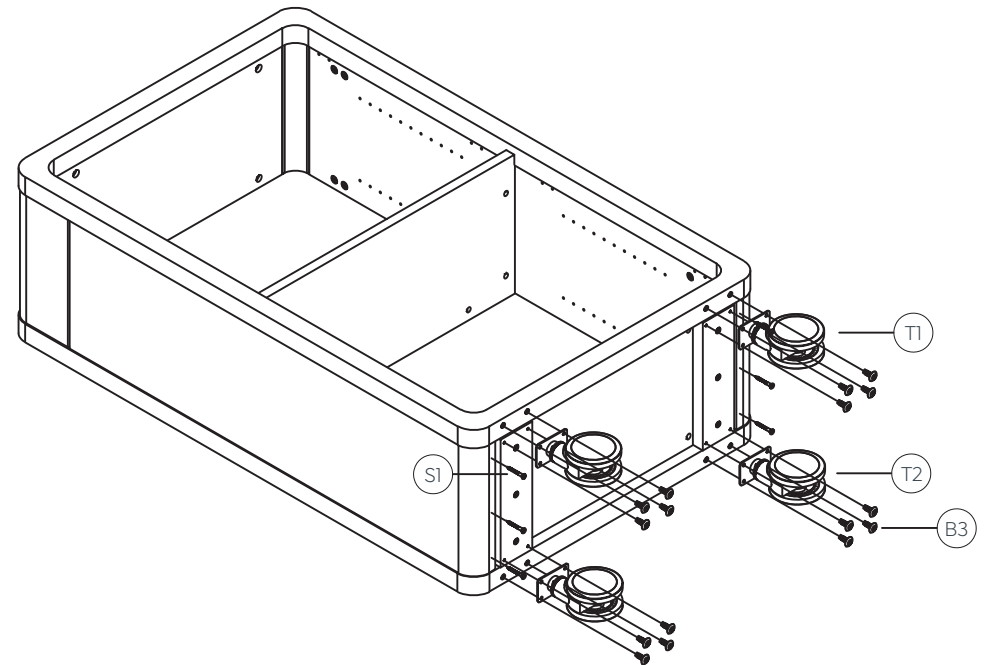

1. Install castors T1 and T2 using screws B3.

Rover Range (50-ROMBC-0919)

Assembly Instructions

STEP 11:

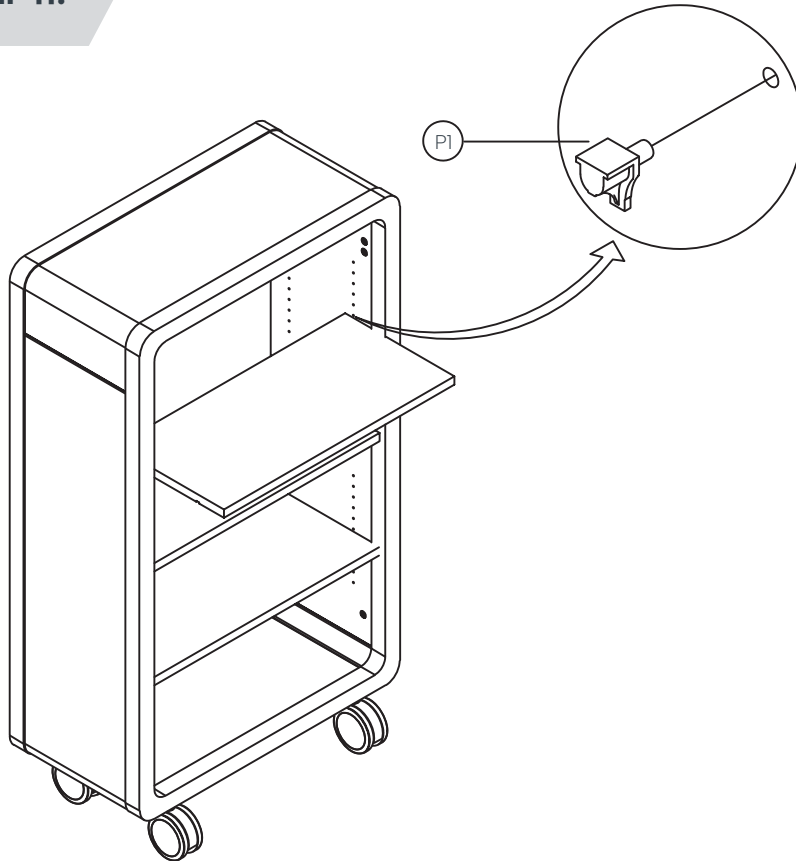

Moveable shelf E assembly

1. Insert threaded dowel pins P1 into panels X, D and Z as illustrated above.
2. Put the two panels E on the top of threaded dowel pins P1 as illustrated above.

Complete:

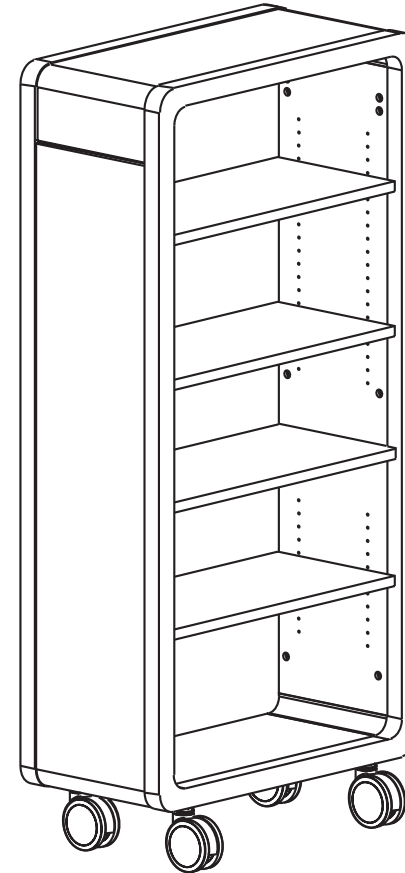

Remove all QC and panel labels and wipe clean using a damp cloth and general household cleaner.



Sydney 02 8188 2732

Melbourne 03 9111 0315

Brisbane 07 3733 1923

Adelaide 08 7111 0810

Perth 08 9468 2707

info@olgoffice.com

myolg.online | olgoffice.com | officedesigner.net | motionoffice.com