

Rover Range (50-ROMCZ-1609)

Assembly Instructions

Rover Range (50-ROMCZ-1609)

Components List

ITEM	DESCRIPTION	QTY
A	Top Panel	1
X	Left Side Panel	1
Z	Right Side Panel	1
D	Back Panel	1
E	Moveable Shelf	4
F	Immovable Panel	1
G	Bottom	1

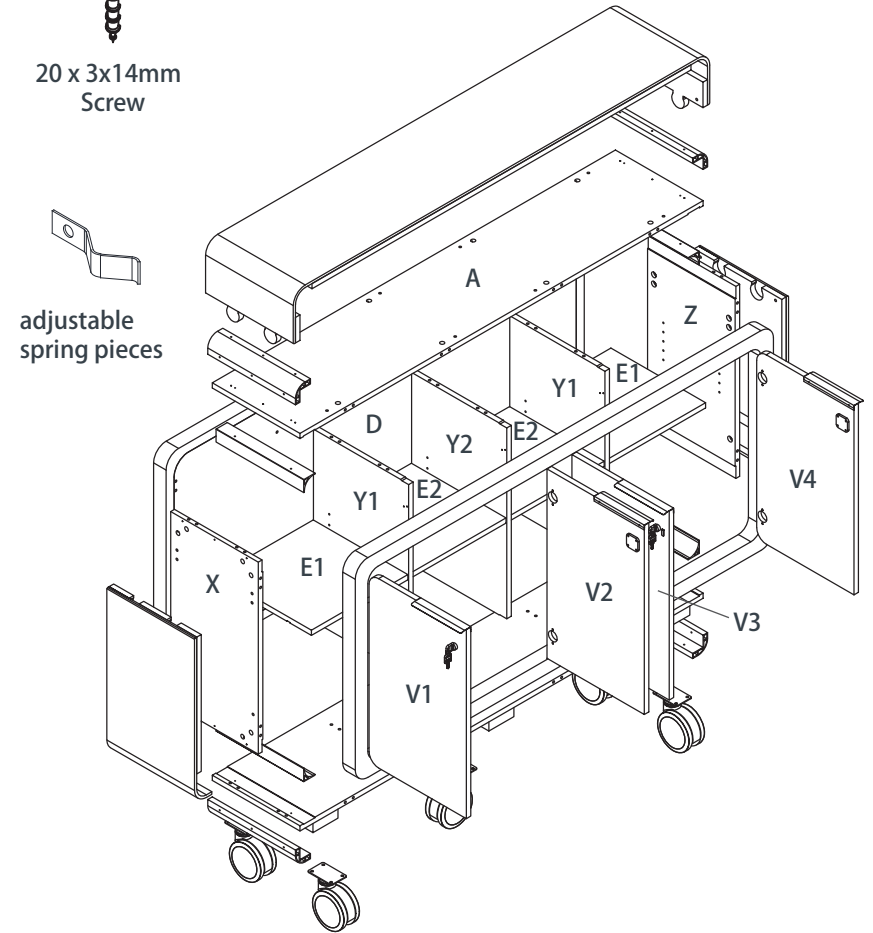
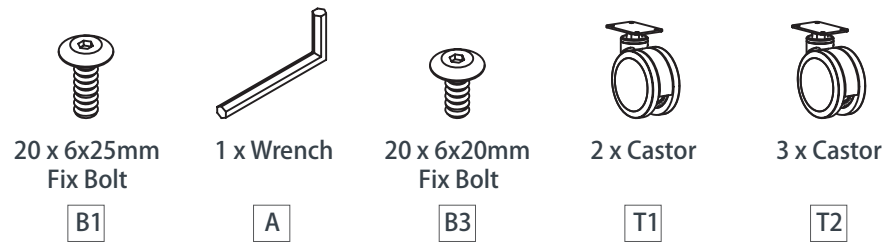
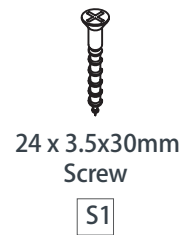
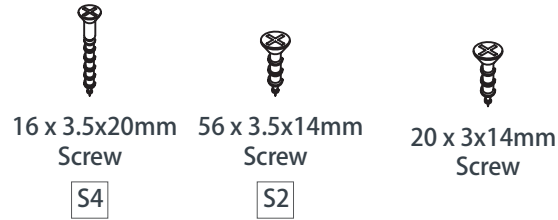

STEP 1:

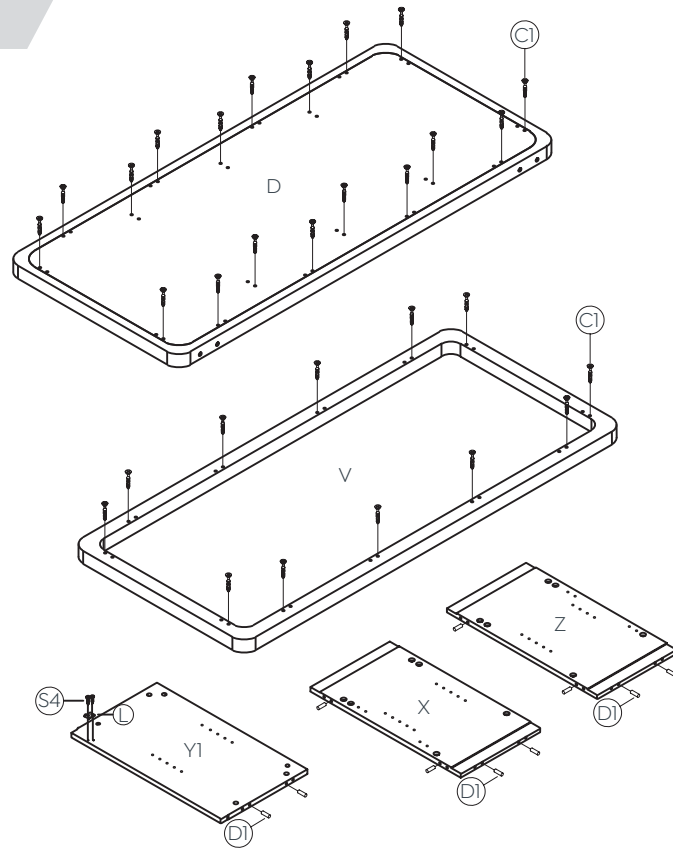

Preparation for panel D, V, Y1, X and Z

1. Insert cam bolts C1 and dowel pins D1 into panels X,Y1,D,X and Z as illustrated above.
2. Locate the trim ring on lock and set aside. Insert cylinder of lock L through hole in Y1 and secure with S4 screws. Add trim ring to lock on outside of Y1.

STEP 2:

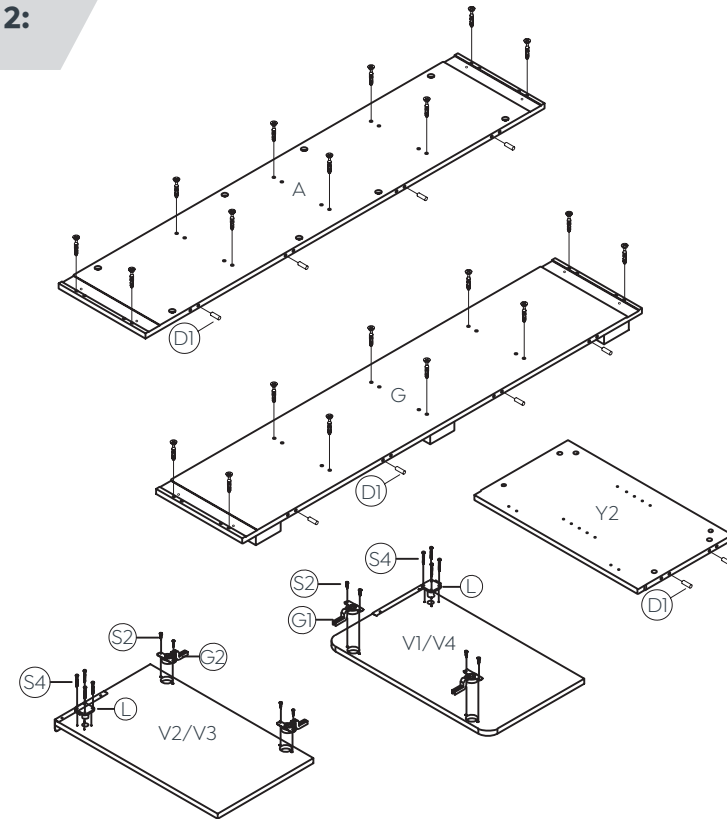

Preparation for panel A, G, Y2, V1, V2, V3 and V4

1. Insert cam bolts C1 and dowel pins D1 into panels A,G and Y2 as illustrated above.
2. Fix hinge stands G1 to panels V1 and V4 with screws S1 as illustrated above.
3. Fix hinge stands G2 to panels V2 and V3 with screws S1 as illustrated above.

Rover Range (50-ROMCZ-1609)

Assembly Instructions

STEP 3:

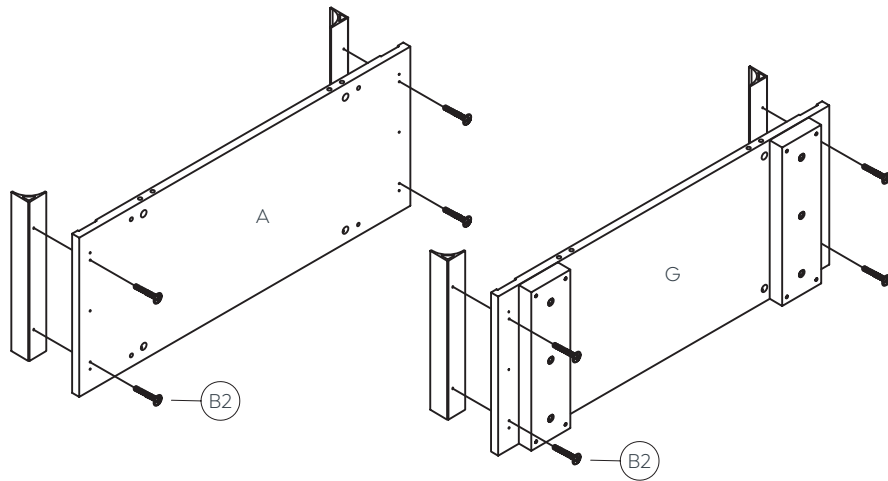

1. Install the aluminum piece and A, G panel together with bolts B2 as illustrated above.

STEP 4:

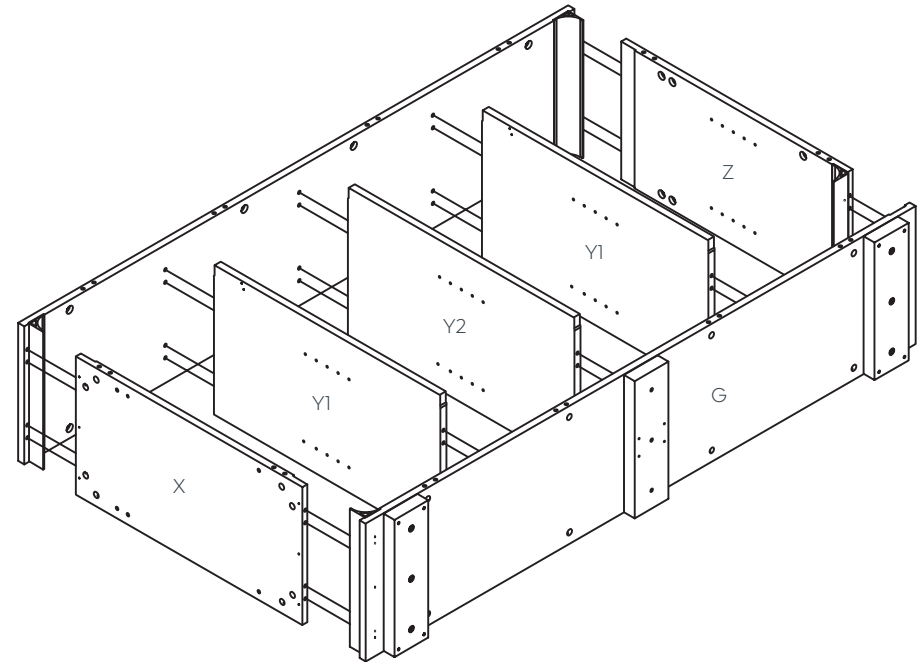

Panel X, Y, A, G, Y1 and Y2 assembly

1. Insert cam bolts C1 and dowel pins D1 on panel A, G into cams on panel X, Z, Y1, Y2, and tighten in a clockwise direction as illustrated above.

STEP 5:

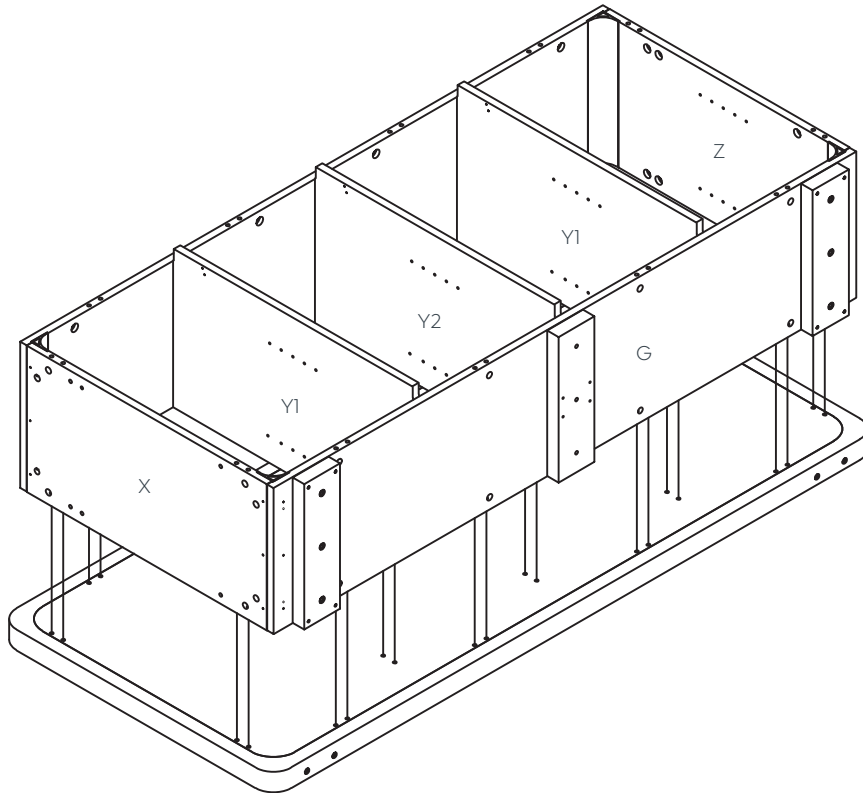

Panel D assembly

1. Insert cam bolts C1 and dowel pins D1 on panel D into cams on panel X, Z, A, G, Y1, Y2 and tighten in a clockwise direction as illustrated above.

STEP 6:

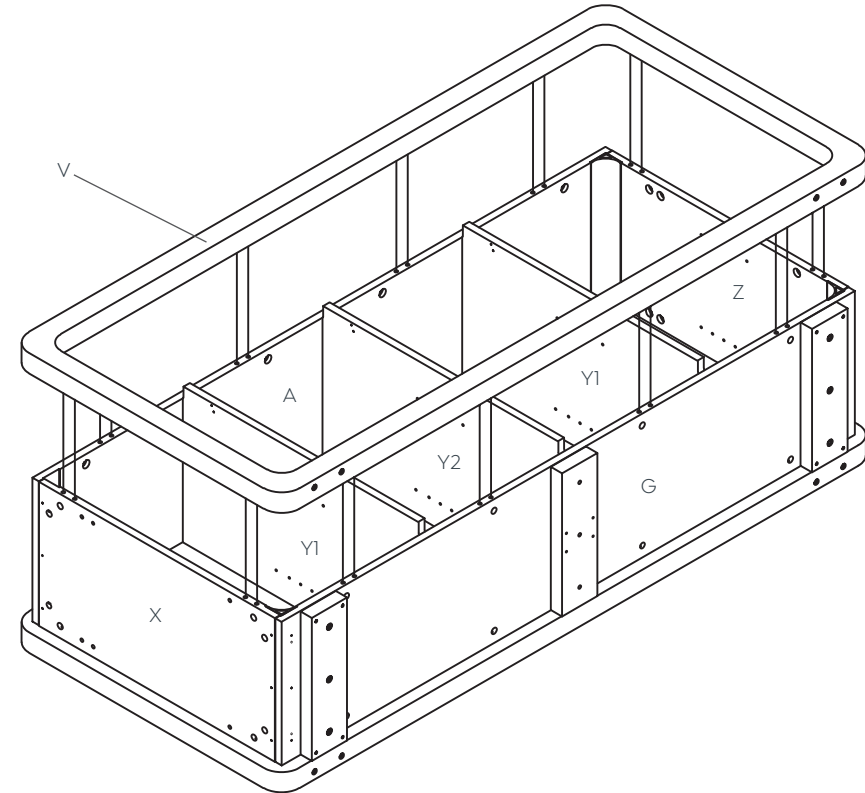

Panel G assembly

1. Insert cam bolts C1 and dowel pins D1 on panel G into cams on panel X, Z, A, G, Y1, Y2 and tighten in a clockwise direction as illustrated above.

Rover Range (50-ROMCZ-1609)

Assembly Instructions

STEP 7:

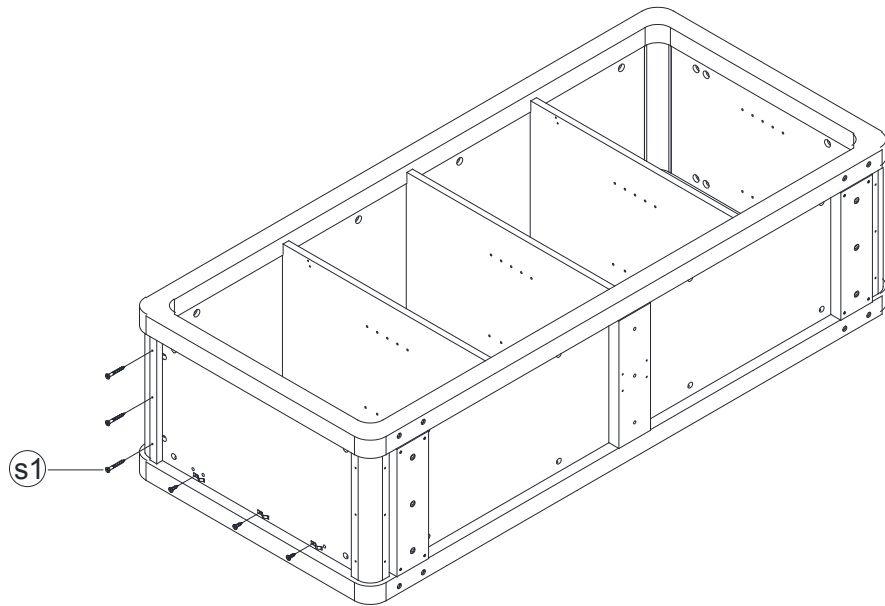

1. Install the aluminum piece and X, Z, A, G panel together with screw S1 as illustrated above.
2. Install the aluminum piece and X, Z panel together with screw as illustrated above.

STEP 8:

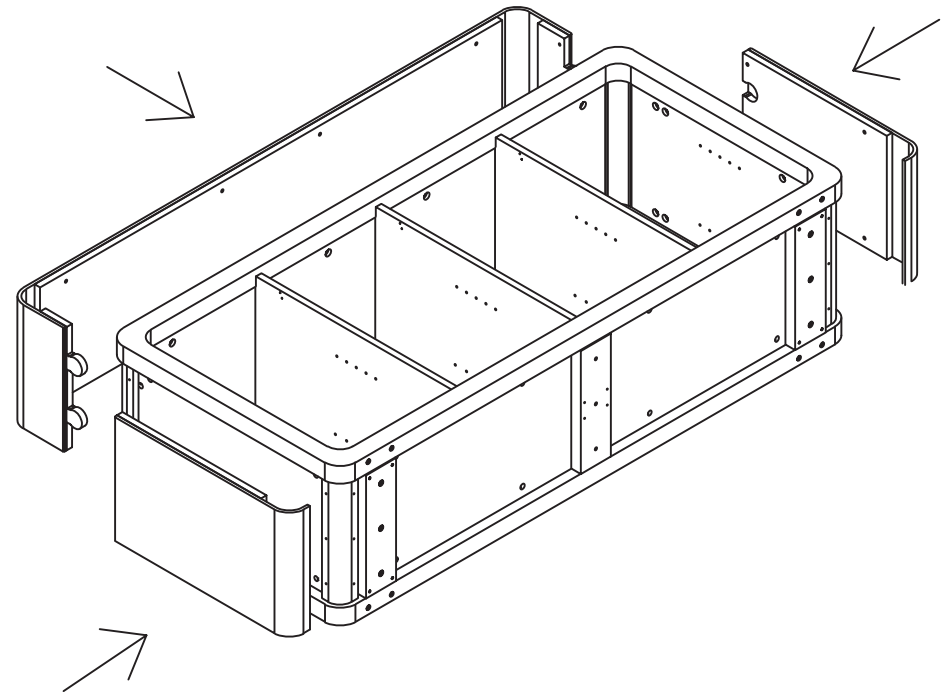

STEP 9:

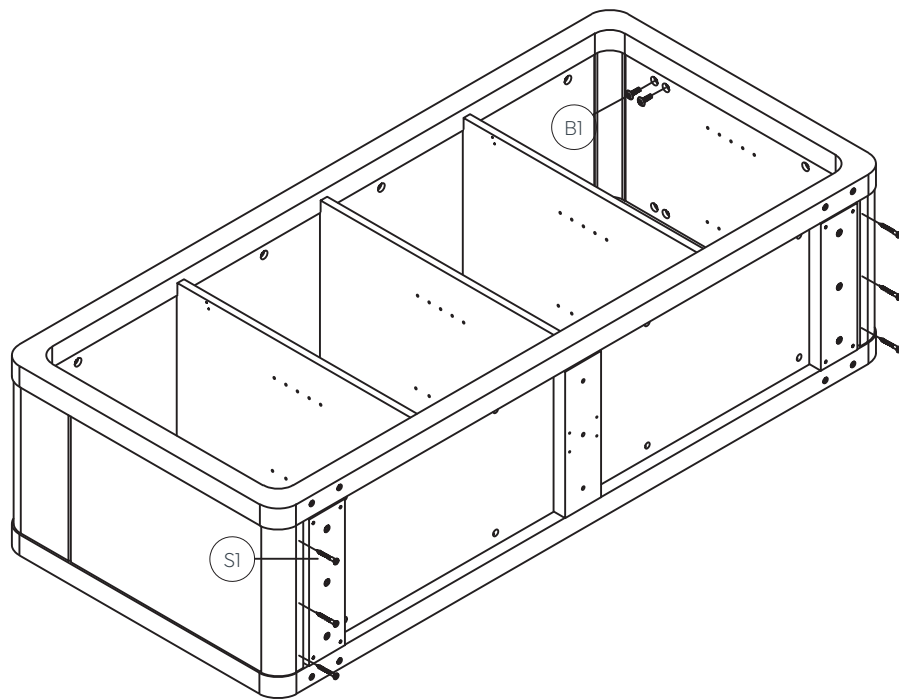

1. Insert Fix Bolt B1 on panel A, X, Z into cams on eva and tighten in a clockwise direction as illustrated above.
2. Install the aluminum piece and G panel together with Screw S1 as illustrated above.

STEP 10:

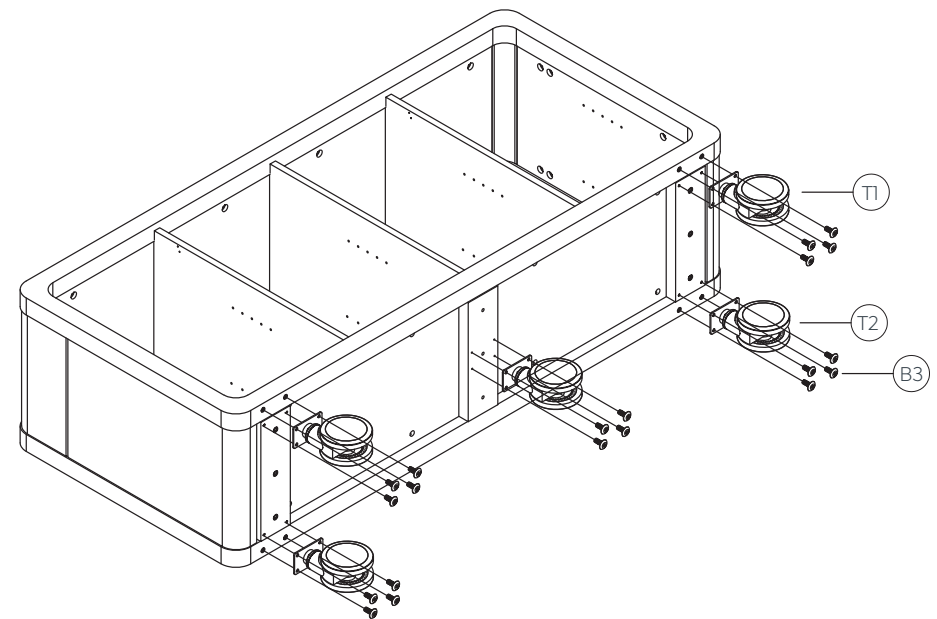

1. Install castors T1 and T2 using screws B3.

Rover Range (50-ROMCZ-1609)

Assembly Instructions

STEP 11:

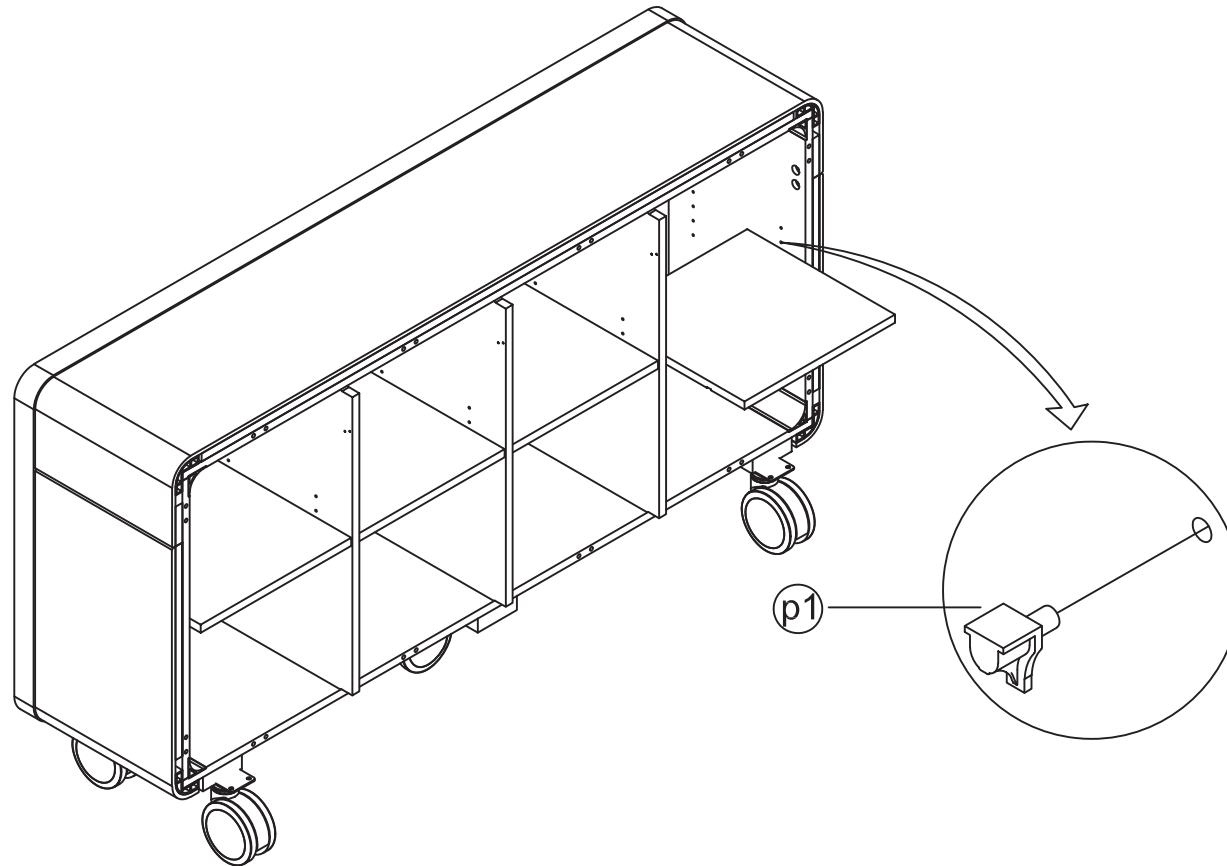

Moveable shelf E assembly

1. Insert threaded dowel pins P1 into panels X, D and Z as illustrated above.
2. Put the four panels E on the top of threaded dowel pins P1 as illustrated above.

STEP 11:

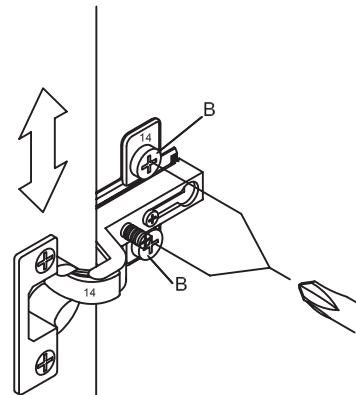
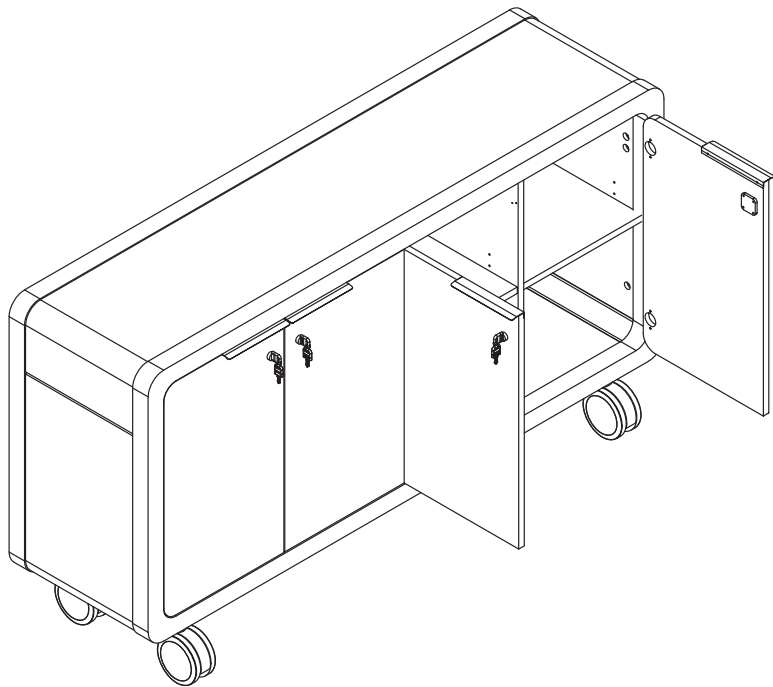

1. Loosen B screws
2. Adjust door vertical
3. Tighten B screws again

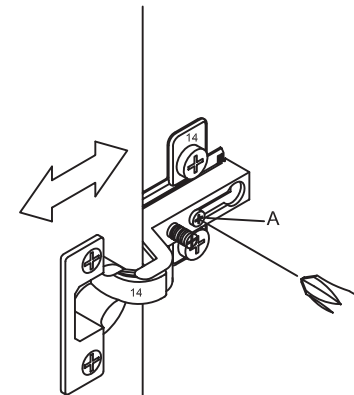

1. Loosen screw A
2. Adjust door in depth
3. Tighten screw A again

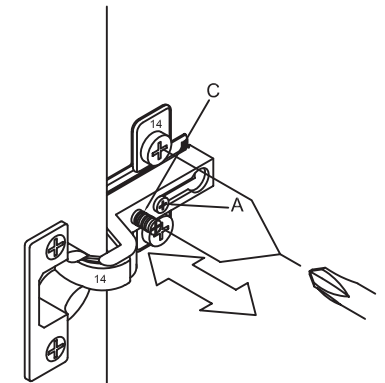

1. Loosen screw A
2. Adjust door sideways with screw C
3. Tighten screw A again

Rover Range (50-ROMCZ-1609)

Assembly Instructions

Complete:

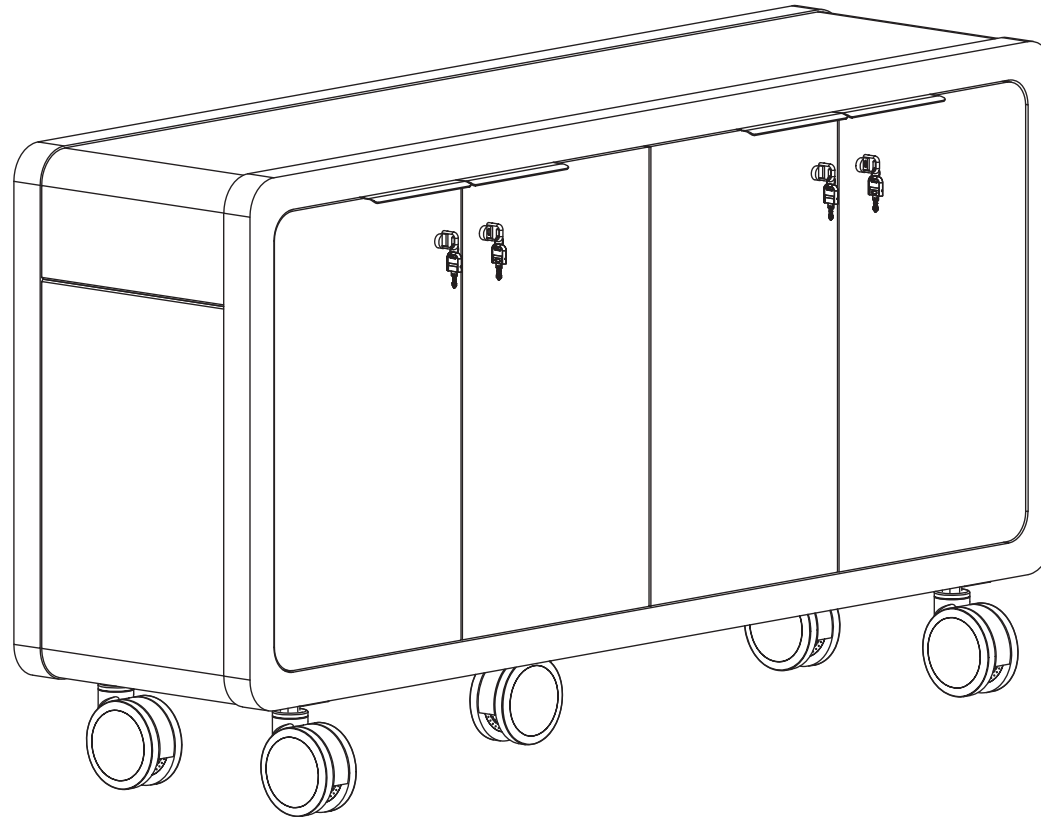

Remove all QC and panel labels and wipe clean using a damp cloth and general household cleaner.



Sydney 02 8188 2732

Melbourne 03 9111 0315

Brisbane 07 3733 1923

Adelaide 08 7111 0810

Perth 08 9468 2707

info@olgoffice.com

myolg.online | olgoffice.com | officedesigner.net | motionoffice.com