

Rover Range (50-ROMWBGLU-0916)

Assembly Instructions

Rover Range (50-ROMWBGLU-0916)

Components List



58 x 6x35mm
Cam Bolt

C1



68 x 8x30mm
Dowel Pin

D1



70 x 5/8"
Cam Cover

C2



40 x 6x25mm
Fix Bolt

B1



12-Cam Bolt

C2

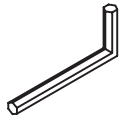

1 x Wrench

A



2 x Castor

T1



2 x Castor

T2

Pre-installed Parts:



Cam

C5

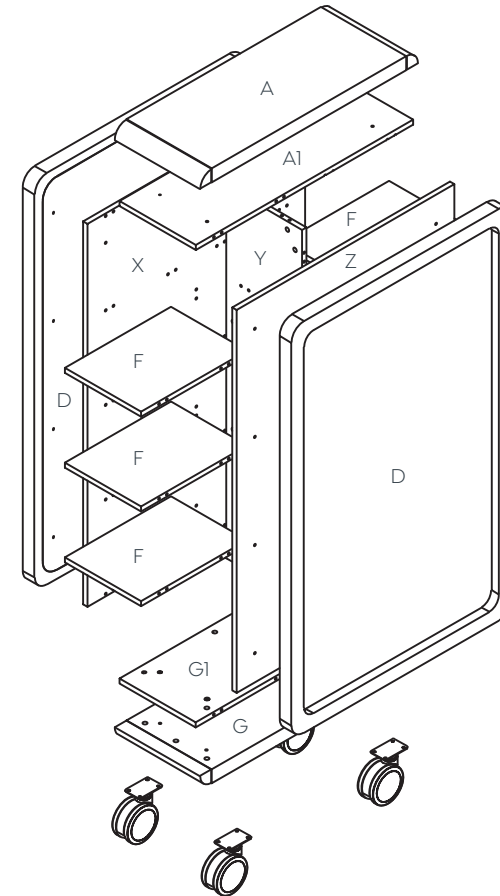

STEP 1:

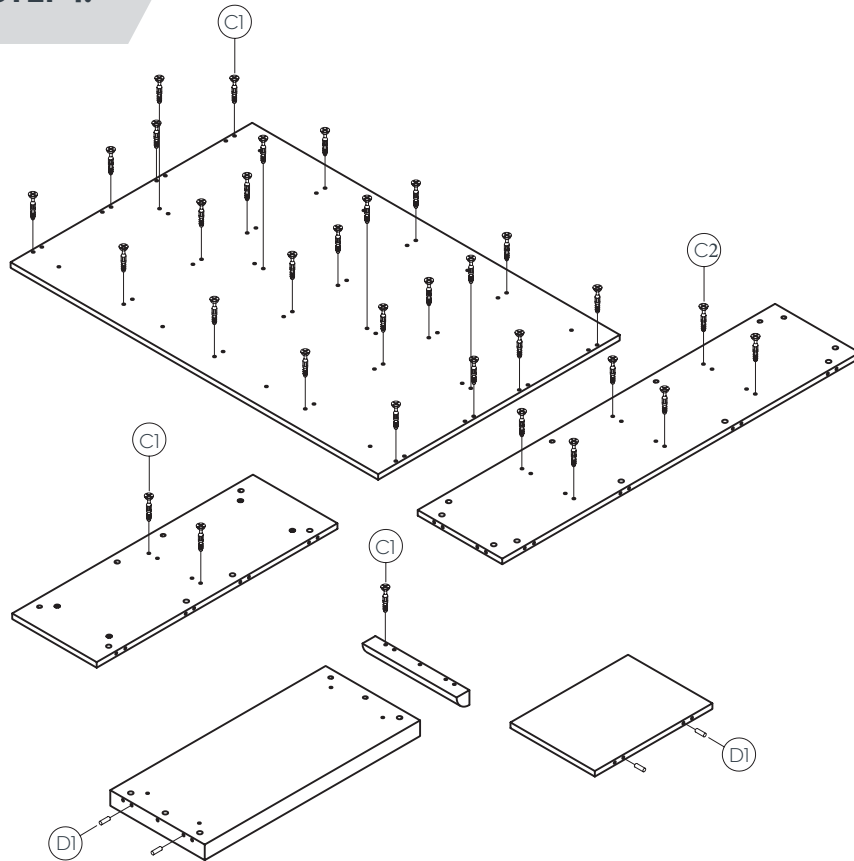

Preparation for panel A, G, A1, G1, Y, X, Z, F.

1. Insert cam bolts C1 and dowel pins D1 into panels X, G, F, X, A1, G1 and Z as illustrated above.
2. Insert cam bolts C2 and dowel pins D1 into panels Y as illustrated above.

STEP 2:

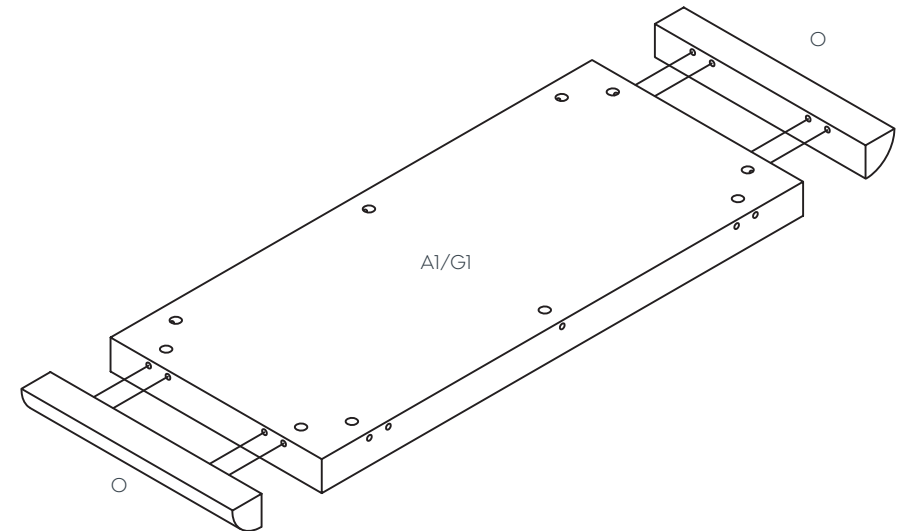

Panel O3, G assembly.

1. Insert cam bolts C1 and dowel pins D1 into panel A1, G1 into cams on panel O and tighten in a clockwise direction as illustrated above.

Rover Range (50-ROMWBGLU-0916)

Assembly Instructions

STEP 3:

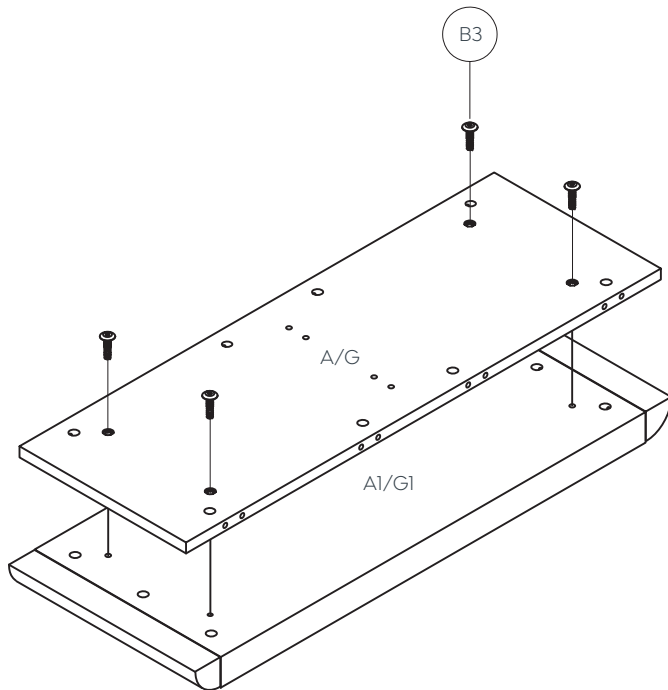

Panel A/G/A1/G1 assembly.

1. Insert threaded Fix Bolt B3 into panels A, A1, G and G1 as illustrated above.

STEP 4:

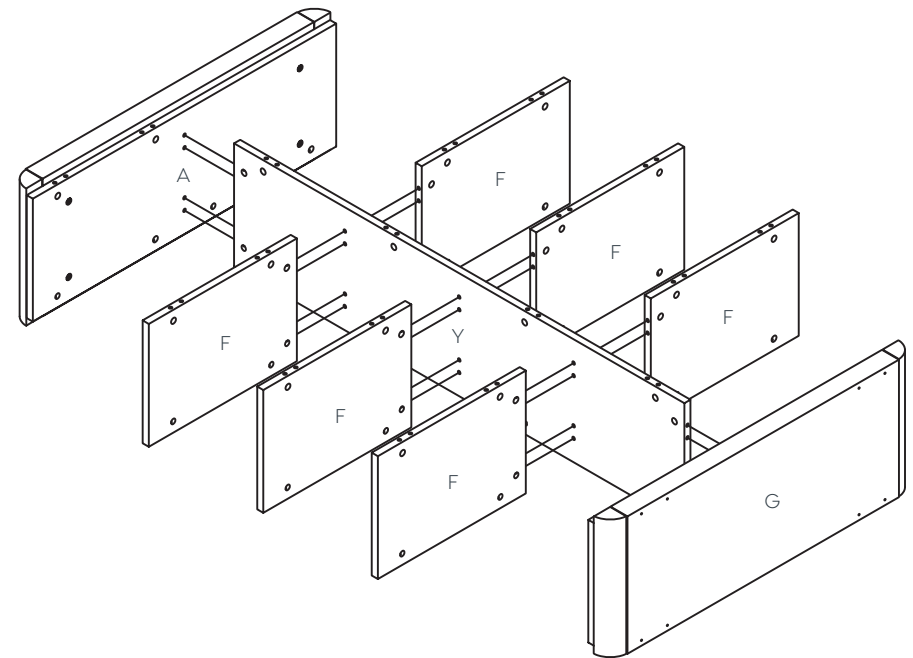

Panel A/G assembly.

1. Insert cam bolts C1 and dowel pins D1 on panel A,G,Y into cams on panel X, Z and tighten in a clockwise direction as illustrated above.

STEP 5:

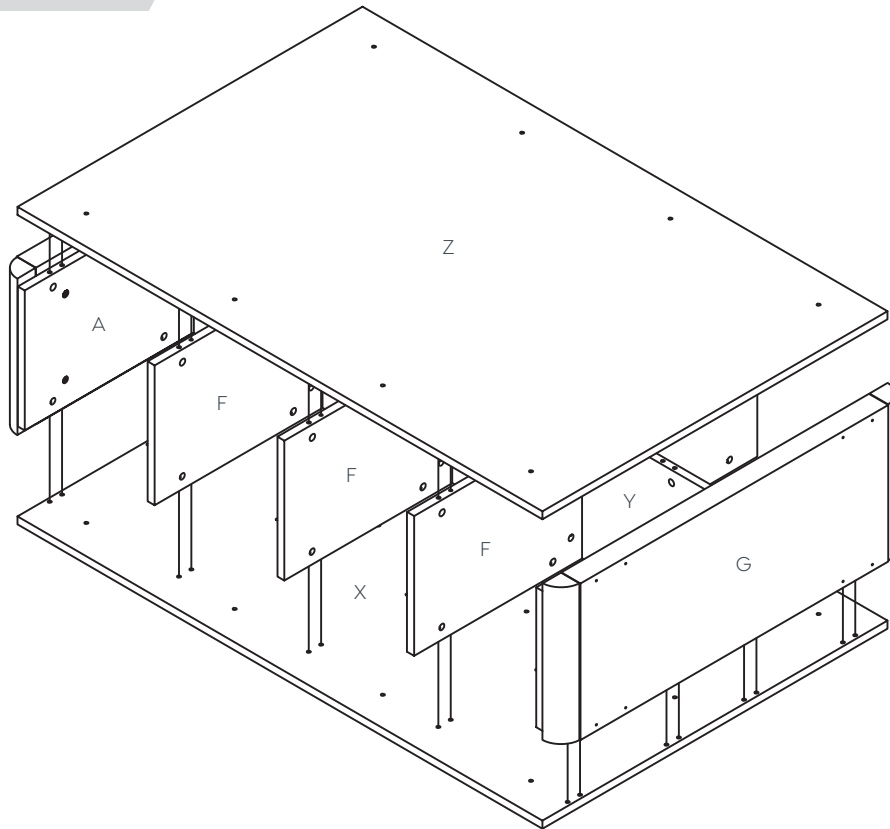

Panel D assembly.

1. Insert cam bolts C1 and dowel pins D1 on panel X, Z into cams on panel A, G, F, Y and tighten in a clockwise direction as illustrated above.

STEP 6:

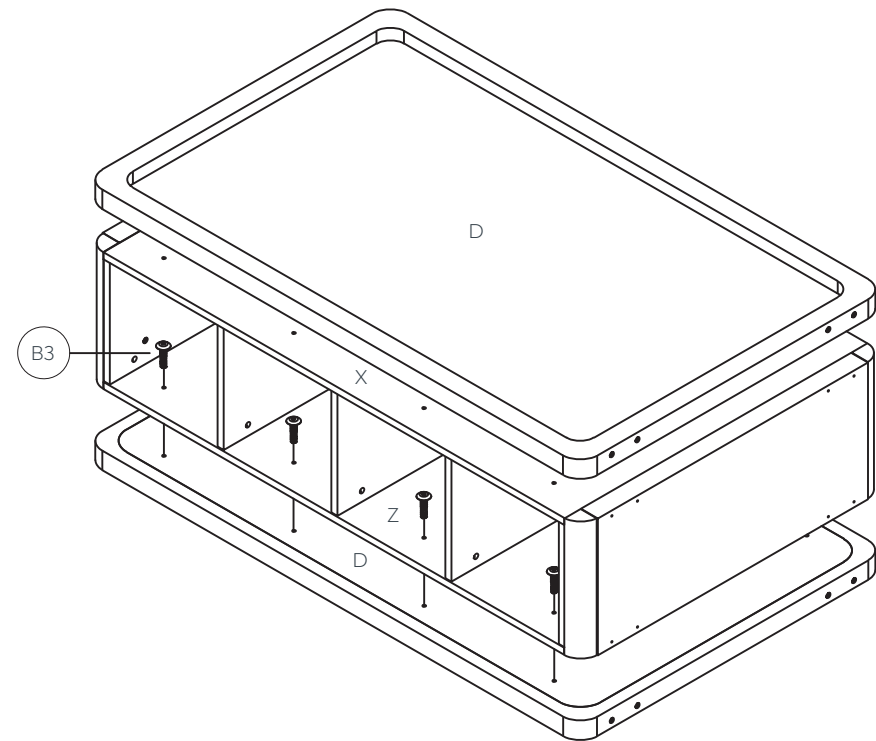

Panel D assembly.

1. Insert threaded Fix Bolt B3 into panels X, Z and D as illustrated above.

Rover Range (50-ROMWBGLU-0916)

Assembly Instructions

STEP 7:

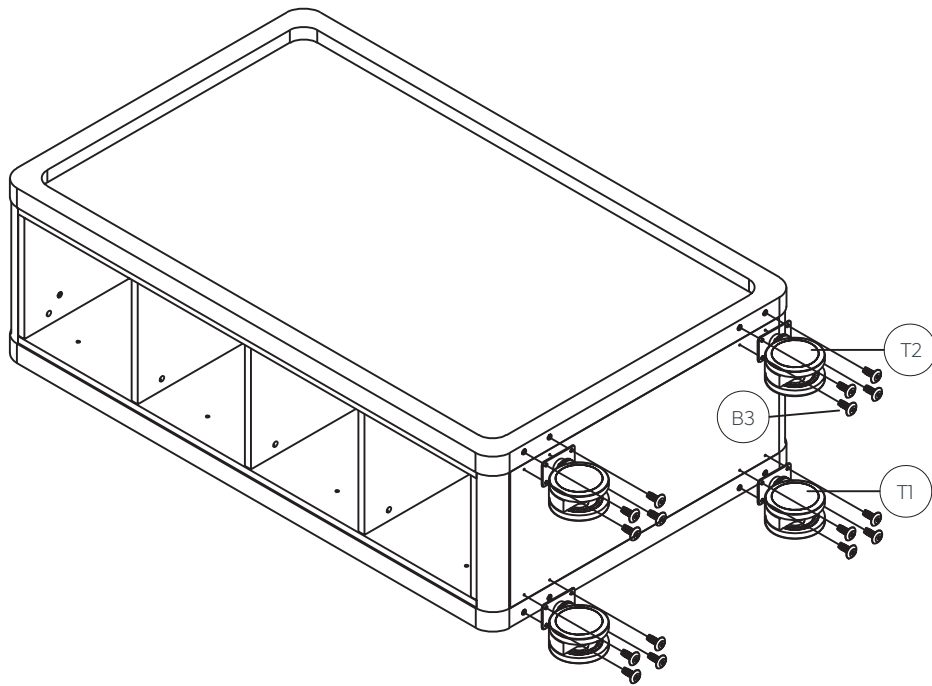

Complete:

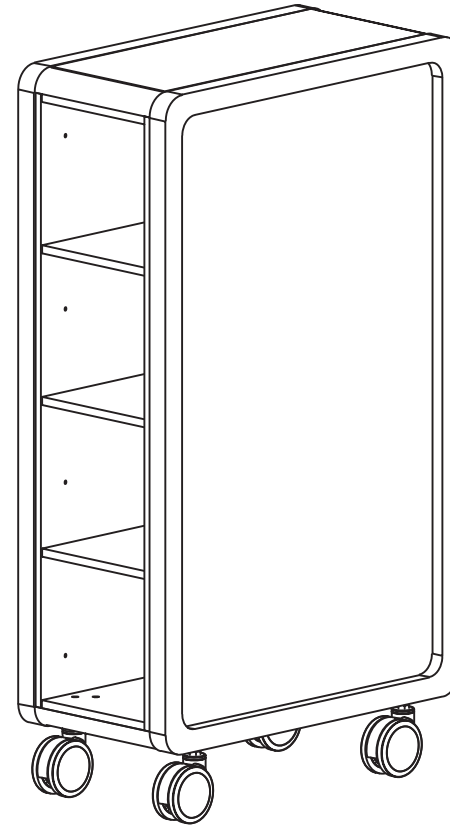

Remove all QC and panel labels and wipe clean using a damp cloth and general household cleaner.



Sydney 02 8188 2732

Melbourne 03 9111 0315

Brisbane 07 3733 1923

Adelaide 08 7111 0810

Perth 08 9468 2707

info@olgoffice.com

myolg.online | olgoffice.com | officedesigner.net | motionoffice.com