

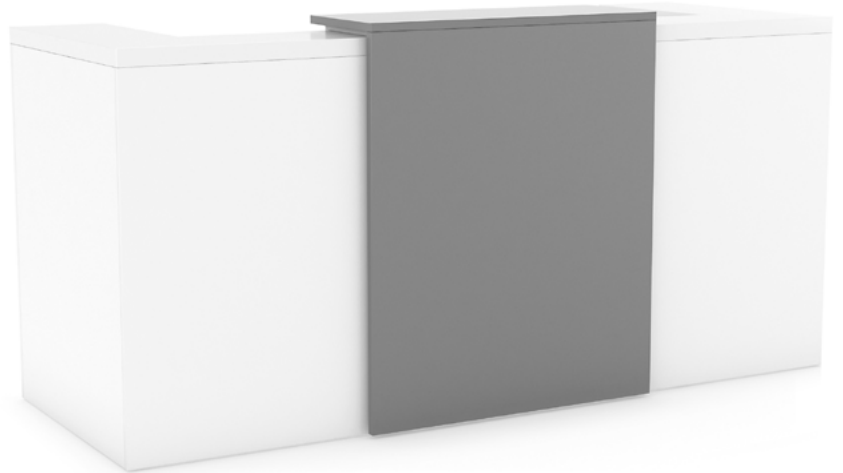

Anvil Reception.

The Anvil reception counter is a great first impression in any workplace. The flat feature panel is a perfect space for company branding. It uses 18 mm White melamine on E1 grade substrate, includes silver centre feature panel and optional desk. 1800 – 2400mm width adjustment.



Features

18 mm White melamine on E1 grade substrate with matching PVC edge

Flush-joined construction detailing

All reception options require freestanding worksurfaces

Silver, centre feature panel

Centred front panel ideal for adding signage or branding

Concealed telescopic chassis adjusts to suit worktop size (extends from 1800 – 2400mm)

Colour Options

Available in white with Silver front included.



Anvil Standard Sizes

Minimum closed, external

1846 x 943 mm (Fits 1800 mm desk)

Maximum open, external

2446 x 943 mm (Fits 2400 mm desk)

Height

1193 mm



Anvil Reception.

Dimensions

Anvil Reception Counter

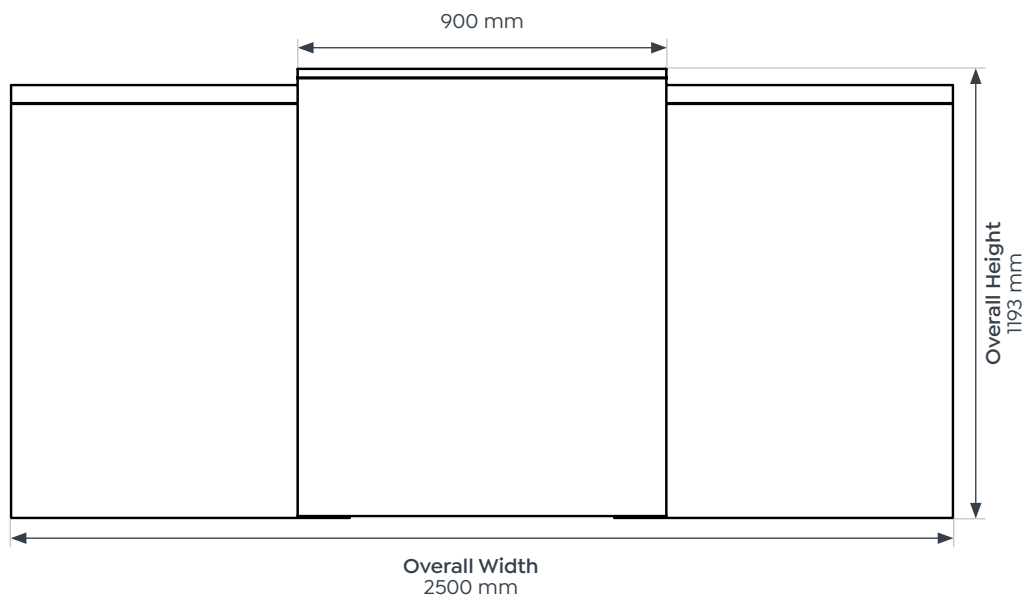
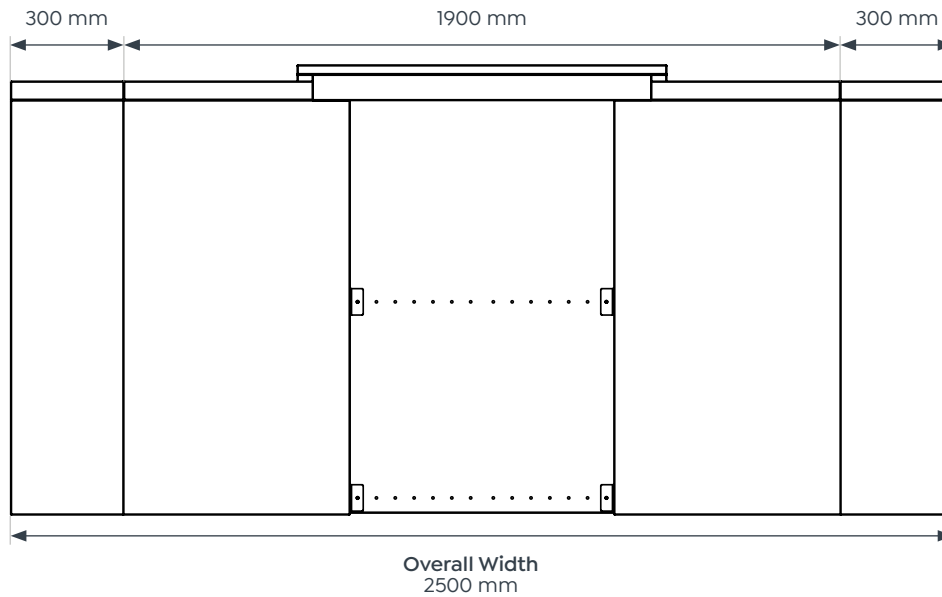

Dimensions

Anvil Reception Counter

