



## Qzone.

Add a bit of private space to your open plan office. The phone booth is perfect for sensitive phone calls, working on confidential documents, or just a bit of peace and quiet. Available in white or new oak with a large range of colour/ print customisations available on the side panels. Optional extras include frosting on the glass, wireless fast charger, stool inside, window panel to back wall or a box shelf upgrade.

### Features

In stock in Grey/ White and Grey/ New Oak

Toughened glass door

Flat packed for easy moving and transportation, fits comfortably in most lifts

Motion sensor, light, extraction fan, GPO & USB power outlet

10 years warranty (excludes electrical components)

Comes with bench to take notes or work on your laptop

Internal walls absorb 75% of sound waves (100 fold reduction in sound intensity)



### Dimensions

#### Single User Pod

Overall Height	2215 mm
Overall Width	1100 mm
Overall Depth	1100 mm





### Noise Reduction

Internal acoustic panelling walls absorb 20dB of noise as test in a simulated environment.



### Built-in Technology

Motion sensor, light, extraction fan, GPO & USB power outlet



### Workstation

Comes with table top to take notes or work on your laptop



### Tailor to Your Space

Many colours to choose from and even print your artwork or logo on outer panels and door



### Kit It Out

Add a wireless fast-charge to the worktop, bookshelf, stool, extra window or a bag hook.



### GECA Certified

Motion sensor, light, extraction fan, GPO & USB power outlet



### Peace of Mind

Comes with table top to take notes or work on your laptop

## Optional Updates

Wireless fast charge in worktop

Change outer e-panel colours: 4 weeks lead time  
 Printing on white outer panel (includes artwork design & approval): 4 weeks lead time

Glass door and/ or rear panel frosting (includes artwork design, work completed by sign maker after assembly)

Window panel to back wall- special order: 14-16 weeks

Box shelf upgrade (second shelf level and bag hook) - special order: 14-16 weeks



## Frame Selection

Stock Option



White

New Oak

## AcoustiQ

Screen Colour Options



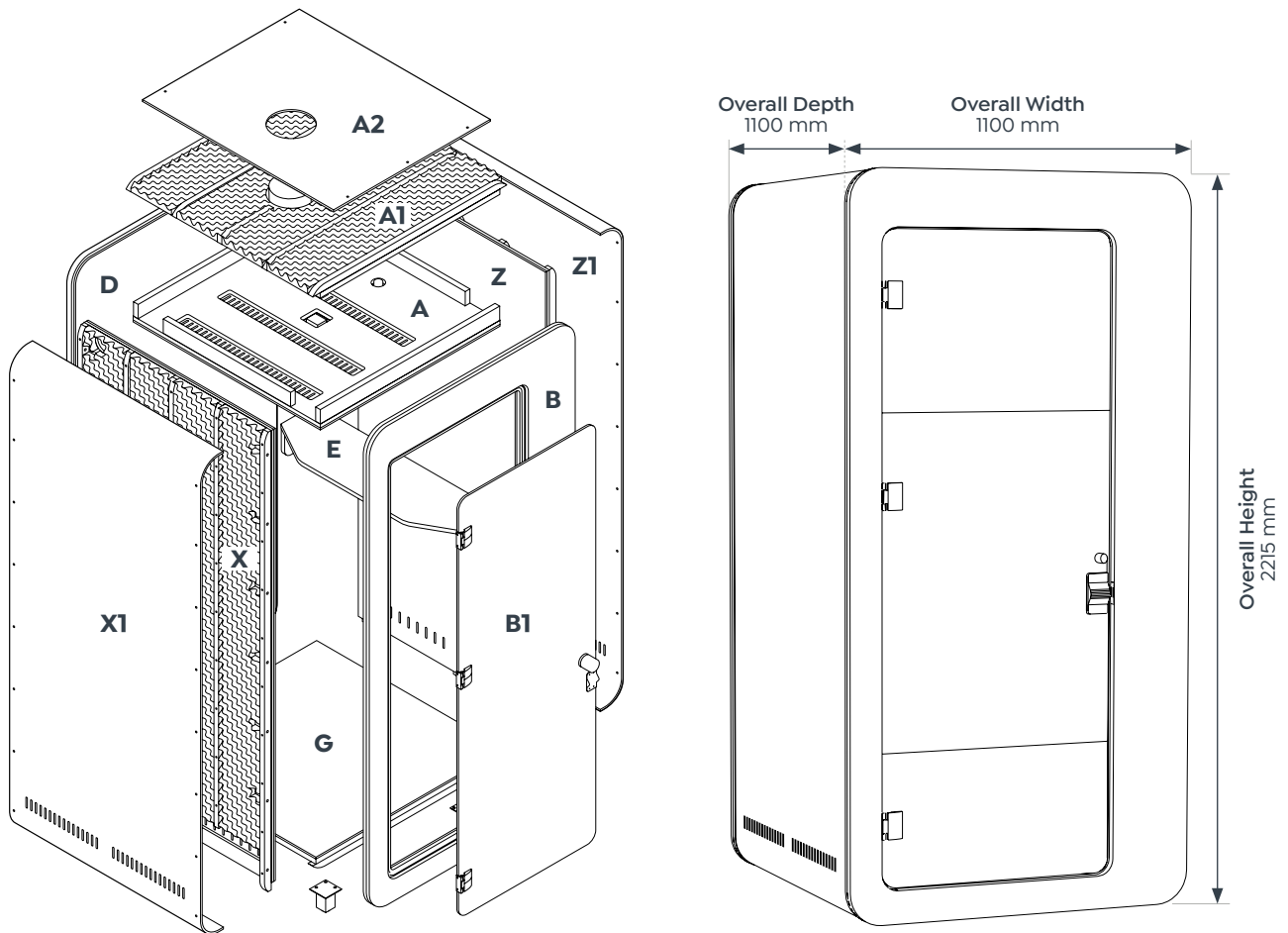

### Specification

**A** Ceiling Panel

**A1** Top Panel

**A2** AcoustiQ Panel

**B** Front Panel

**B1** Glass Door

**D** Back Panel

**E** Shelf

**G** Bottom Panel

**X** Side Panel

**X1** AcoustiQ Side Panel

**Z** Side Panel

**Z1** AcoustiQ Side Panel

Weight: 245 kg

Size: 1100 x 1000 x 2215 mm

### Packing Type

10 cartons (including Softwiring)

Max weight: 60 kg

Min weight: 1 kg

Assembly time: 2 People, 2 Hours, simple electrical work required

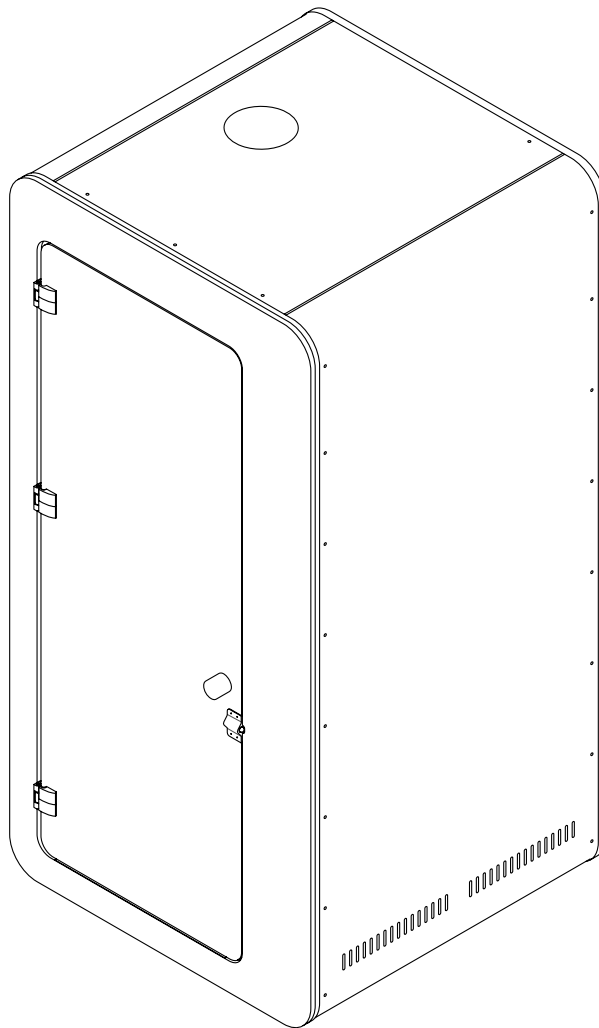

### Carton Dimensions and Weights:

1 x	1100 mm (w)	x	1065 mm (d)	x	70 mm (h)	x	-33 kg
1 x	1065 mm (w)	x	1025 mm (d)	x	115 mm (h)	x	-27 kg
1 x	1100 mm (w)	x	1065 mm (d)	x	85 mm (h)	x	-28 kg
1 x	1065 mm (w)	x	1065 mm (d)	x	170 mm (h)	x	-19 kg
1 x	2190 mm (w)	x	1065 mm (d)	x	75 mm (h)	x	-38 kg
1 x	2280 mm (w)	x	1065 mm (d)	x	70 mm (h)	x	-60 kg
1 x	2280 mm (w)	x	1065 mm (d)	x	70 mm (h)	x	-43 kg
1 x	2000 mm (w)	x	1065 mm (d)	x	50 mm (h)	x	-21 kg
1 x	210 mm (w)	x	310 mm (d)	x	90 mm (h)	x	-1 kg