

---

## Rhodes Modular Shelving (50-MSCAD8036)

Assembly Instructions

# Rhodes Modular Shelving (50-MSCAD8036)

## Components List

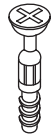

16 x 6x35mm  
Cam Bolt

C1



4 x 3.5x25mm  
Screw

S2



16 x 8x30mm  
Dowel Pin

D1



16 x 5/8"  
Cam Cover

C2

### Pre Installed Parts:



Cam

C5

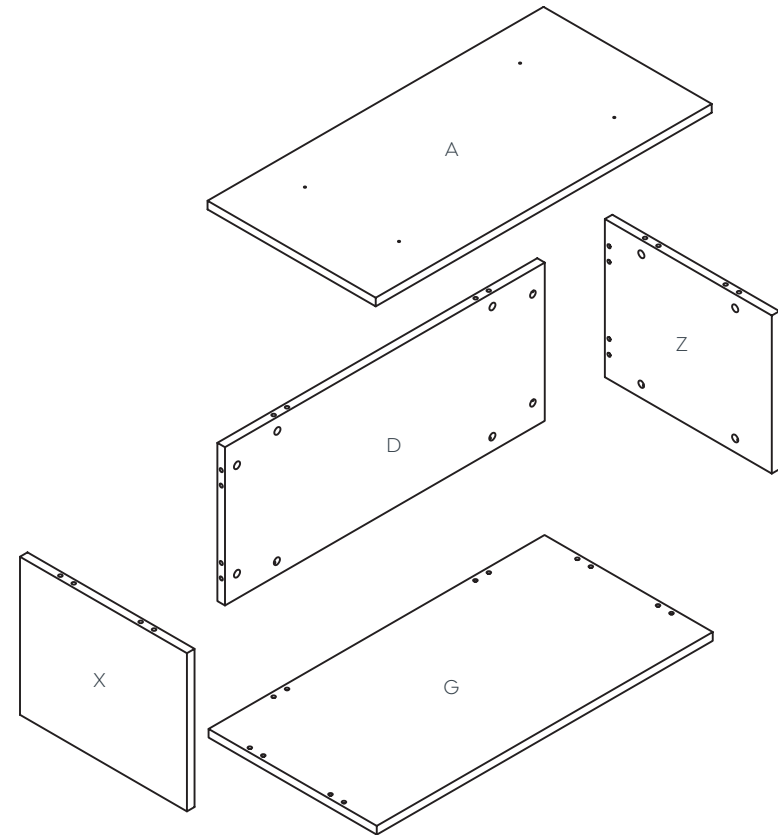

### STEP 1:

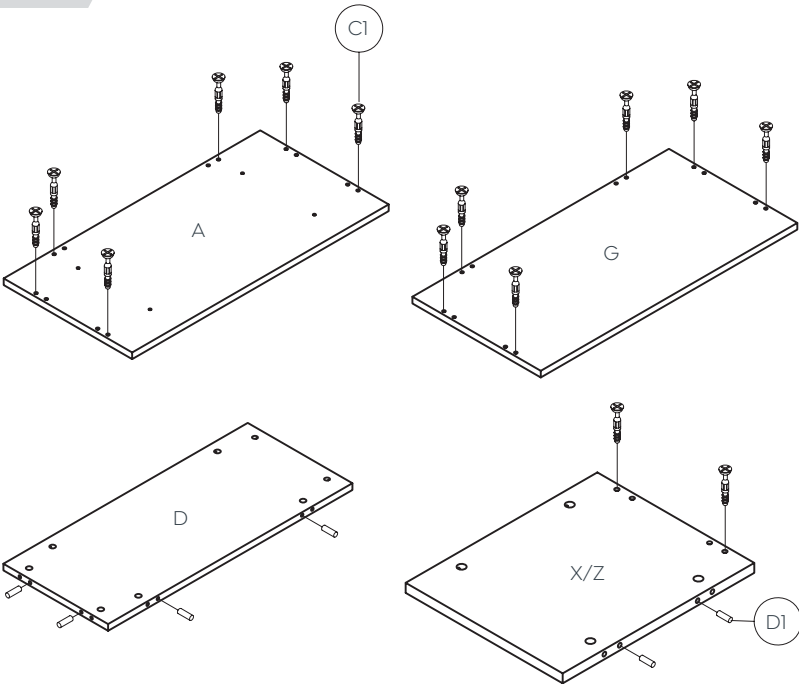

#### Preparation for panels A, G, X, Z and D.

- 1. Insert cam bolts C1 into panels A and G as illustrated above.
- 2. Insert dowel pins D1 into panels D, X and Z as illustrated above.

### STEP 2:

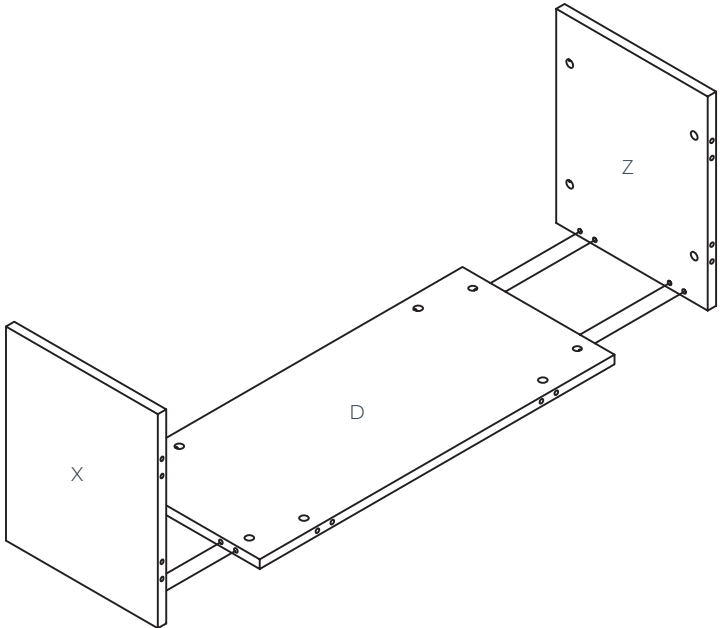

#### Panel X, Z and D assembly.

- 1. Insert cam bolts C1 and dowel pins D1 on panel X, Z into cams on panel D and tighten in a clockwise direction as illustrated above.

# Rhodes Modular Shelving (50-MSCAD8036)

## Assembly Instructions

### STEP 3:

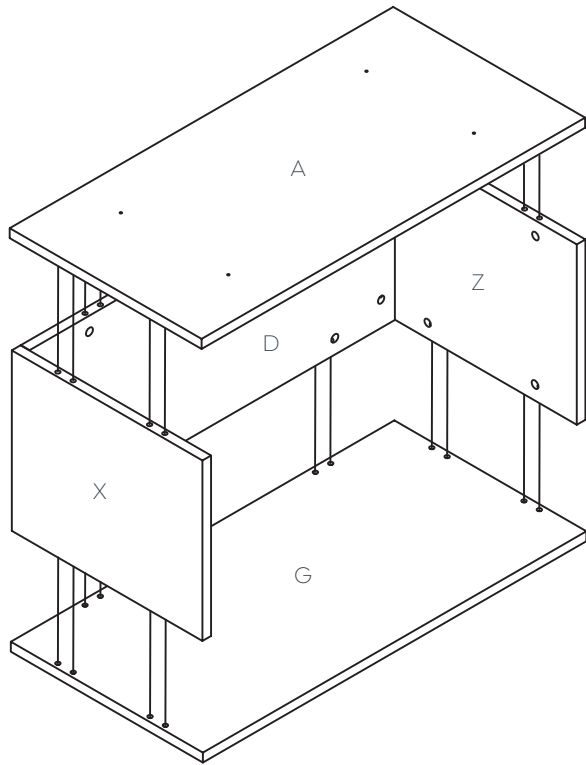

#### Panel A and G assembly.

1. Insert cam bolts C1 and dowel pins D1 on panel A, G into cams on panel X, D, Z and tighten in a clockwise direction as illustrated above.

### STEP 4:

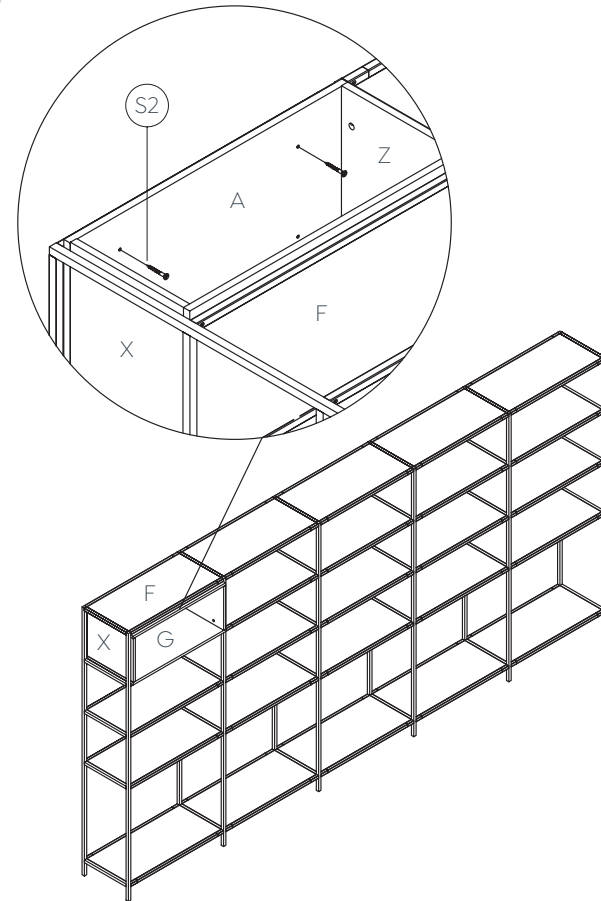

1. Put the cabinet on the shelf.
2. Fix the cabinet on top of shelf using screws S2.

**Complete:**

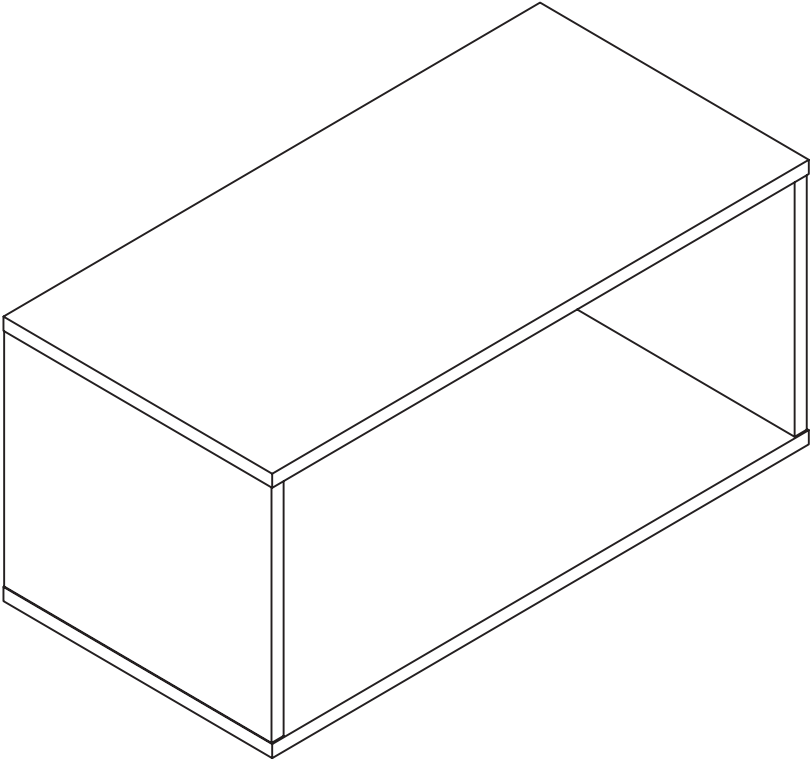

Remove all QC and panel labels and wipe clean using a damp cloth and general household cleaner.



**Sydney** 02 8188 2732

**Melbourne** 03 9111 0315

**Brisbane** 07 3733 1923

**Adelaide** 08 7111 0810

**Perth** 08 9468 2707

[info@olgoffice.com](mailto:info@olgoffice.com)

[myolg.online](https://myolg.online) | [olgoffice.com](https://olgoffice.com) | [officedesigner.net](https://officedesigner.net) | [motionoffice.com](https://motionoffice.com)